

The National Economy as an Example of Control Under Conflict/Cooperation- A Simulation Approach

Robert L. Drake, Ph.D., P.E.
Department of Electrical and Computer Engineering
Christian Brothers University
Memphis, Tennessee
rdrake@cbu.edu

BACKGROUND

The work reported here is the result of teaching a course entitled ECE 488 Modeling and Simulation in Engineering Problems. This course is offered to students in both engineering and non-engineering. All students are required to simulate several dynamic systems during the semester at least one of which must be socio-political-economic (SPE) in nature. As instructor of the course, the writer chose the initial model of the national economy as an example of SPE systems to present to the class. This model was taken from reference [1] initially, and then as discussion progressed “refinements” were added. One of these refinements were reported in an earlier paper [2], where additional work suggested includes that of possible conflicts between the goals of government and the goals of business. The work reported here is the first attempt of the writer to approach that problem.

MODEL

The model hypothesized in this work is shown in the block diagram of Figure 1. Although inspired by the model suggested in reference [1], the model differs in several respects, among which are the inclusion of business investment as a separate input of the two-input system, identification of separate decision-making (controllers) for government and business, identification of different performance indices for government and business, and inclusion of two distinct outputs from the system. The inputs to the system are shown as business reference input (R_b) and the government reference input (R_g). The outputs from the system are shown as the national income level (Y_g) and the business income level (Y_b).

Figure 2 shows the identification of two performance indices chosen in this study. The performance index for government is based on the error, or difference, between the desired change in national income level and the measured change, E_g . In this case the integral squared value of this error is taken as the performance index. For business the error, or difference, is E_b as measured by the desired change in business income and the actual value. Again, the integral squared value of this error is used as the performance index.

Figure 3 shows the proportional plus integral (PI) controller chosen for the government controller. The controller constants were chosen to provide critical damping for the isolated government system. The government system is defined as isolated when the business input is set to zero (command for no change) and the business spending signal (BS) is set to zero. The simulation of the isolated government loop is shown in Figure 5 along with the indicated integral square error (ISE_g) of 6.681 for the unit step response which can be checked with theory for this particular index of performance. Figure 4 shows the PI controller chosen for the isolated business loop and Figure 6 shows the simulation result for this case where the ISE_b is 2.5 which also is checked by application of theory.

In Figure 1 the system representing government and production operations is shown with time constant of 4 time units and “dc” gain of 1. The system representing business operations is shown with time constant of 1 time unit and gain of 1.

DEFINITION OF CONFLICT AND COOPERATION

In Figure 2 the goal of government is to reduce as much as possible the performance index defined in this case as the integral square of the error signal E_g shown as ISE_g. The goal of business is to reduce ISE_b as much as possible. In the model shown, there is coupling between the government loop and the business loop with the result that propagation of signals in one loop affects the operation of the second loop. In the context of this work, conflict is defined to exist if the effect of the first loop upon the second loop is such that the performance index of the second is worsened, or increased in this case where the goal is to decrease the ISE. Similarly, cooperation is defined to exist if the coupling effect improves the performance index.

Simulation makes obvious that conflict and cooperation can exist because of signal injection or because of system modification without signal injection, or both. In Figure 7 no signal is injected by the business system, but because of the presence of the business feedback loop the government performance index ISE_g is increased by a factor of (34.81/6.68), or 5.2 to 1. By the definition above, conflict exists. On the other hand, in Figure 8 signal injection at the business reference input R_b along with the feedback in the business loop results in ISE_g increase by a factor of (132.3/6.68), or 19.8 to 1. Conflict from signal injection in this case results from the opposite signs in the reference input to the government loop and reference input to the business loop.

ADDITIONAL SIMULATION RESULTS

Additional simulation results are shown in Figures 9 and 10. Figure 9 shows the variation of the performance indices ISE_g and ISE_b with government reference R_g with business reference R_b held constant at unity. By the definitions above for cooperation and conflict,

cooperation increases as R_g varies from 0 to 1 and conflict increases as R_g varies from 0 to -1. There is a rapid increase in the error indices as the conflict increases and a rapid decrease in the error indices as the cooperation increases. Figure 10 shows the variation of the error indices as a function of the business reference R_b with the government reference held constant at unity. Again, there is a rapid increase in error indices as conflict increases and a rapid decrease in error indices as cooperation increases.

SUMMARY AND CONCLUSIONS

(1) Conflict may be defined by the actions of one participant, say business, tending to increase the performance index being minimized by the second participant, say government. Cooperation may be defined as existing when the actions of one of the participants tends to reduce the performance index being minimized by the second participant.

(2) Cooperation/conflict may result from either signal injection or from system modification, or both.

FUTURE WORK

(1) The effects of consumers should be added to the model. With three participants present, the possibility of joint cooperation/conflict arises. Include the effect of foreign investment.

(2) Practical data and reasonable scaling limits should be added. This probably requires participation of personnel with backgrounds in business and economics.

(3) Re-phrase the problem in terms of state variables and vector-matrix operations. Use modern control theory to re-design the controllers. Consider the possibility of decoupling output except from one input.

FINAL COMMENTS

(1) This is a work in progress.

(2) Results and conclusions, although believed to be original, are preliminary and should be considered as such.

REFERENCES

- [1] S.M. Shinnars, Modern Control Theory and Application, Reading, MA, Addison-Wesley, 1972.
- [2] R.L. Drake, "Do Checks and Balances Contribute to Cycles in the Economy?", MAESC 2003, Christian Brothers University, Memphis, TN, May 15, 2003.

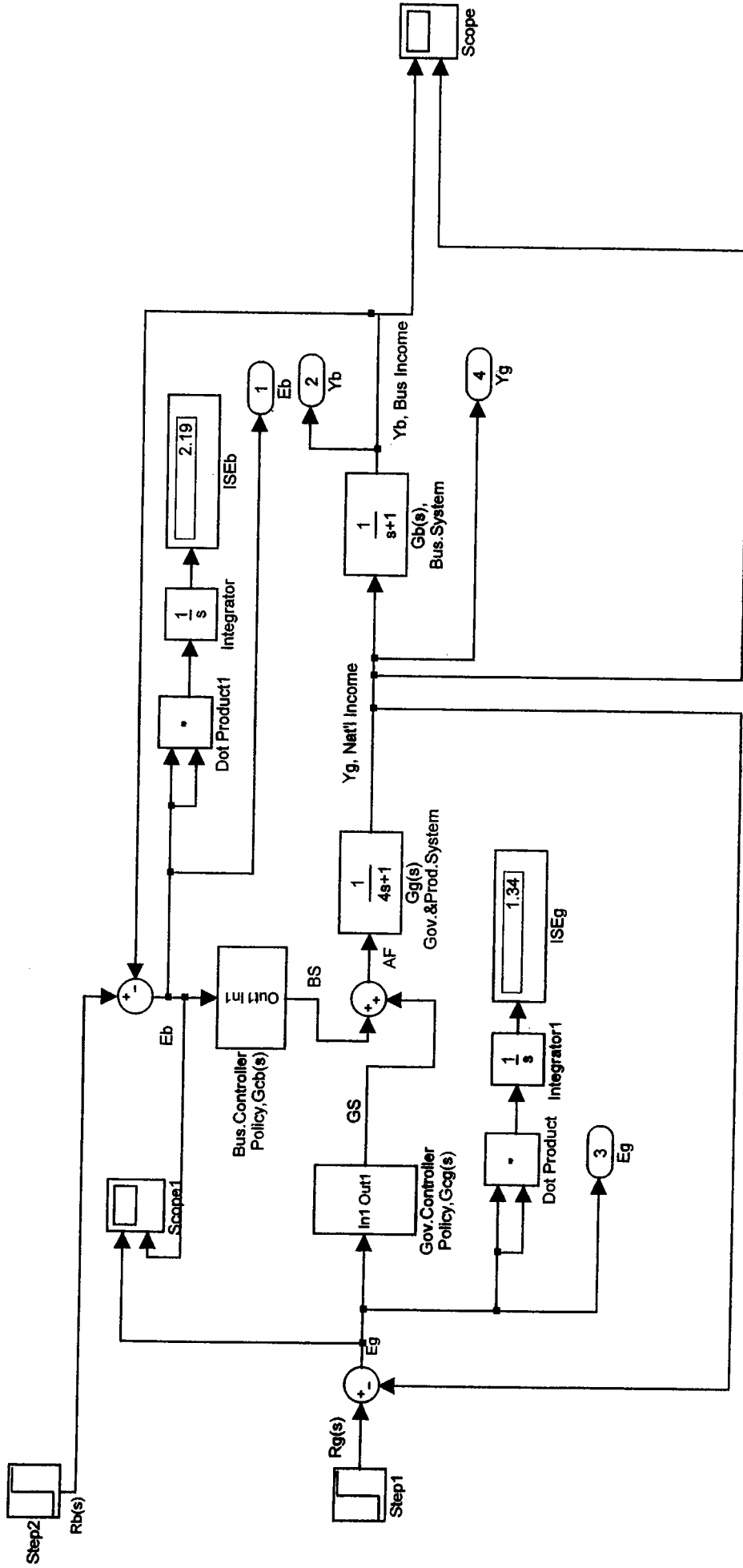

FIGURE 2 BLOCK DIAGRAM with VIRTUAL INSTRUMENTATION and COMPUTATION

AF=Available Funds

GS(s)=Gov't Spending

BS= Bus. Spending

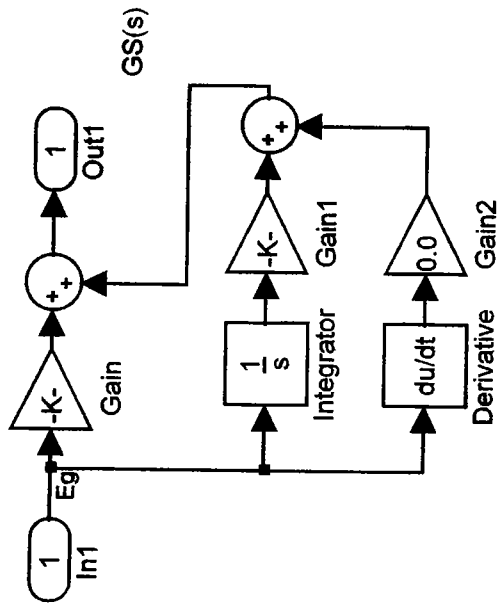

FIGURE 3 GOVERNMENT PI CONTROLLER

$Kp=0.1716$

$Ki=0.0858$

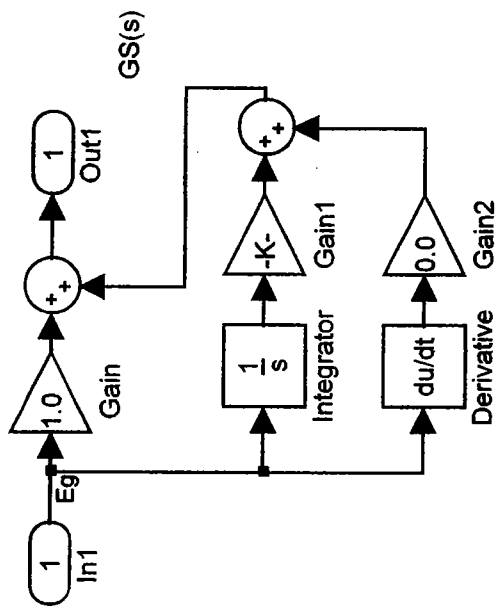

FIGURE 4 BUSINESS PI CONTROLLER

$Kp=1.0$
 $Ki=0.25$

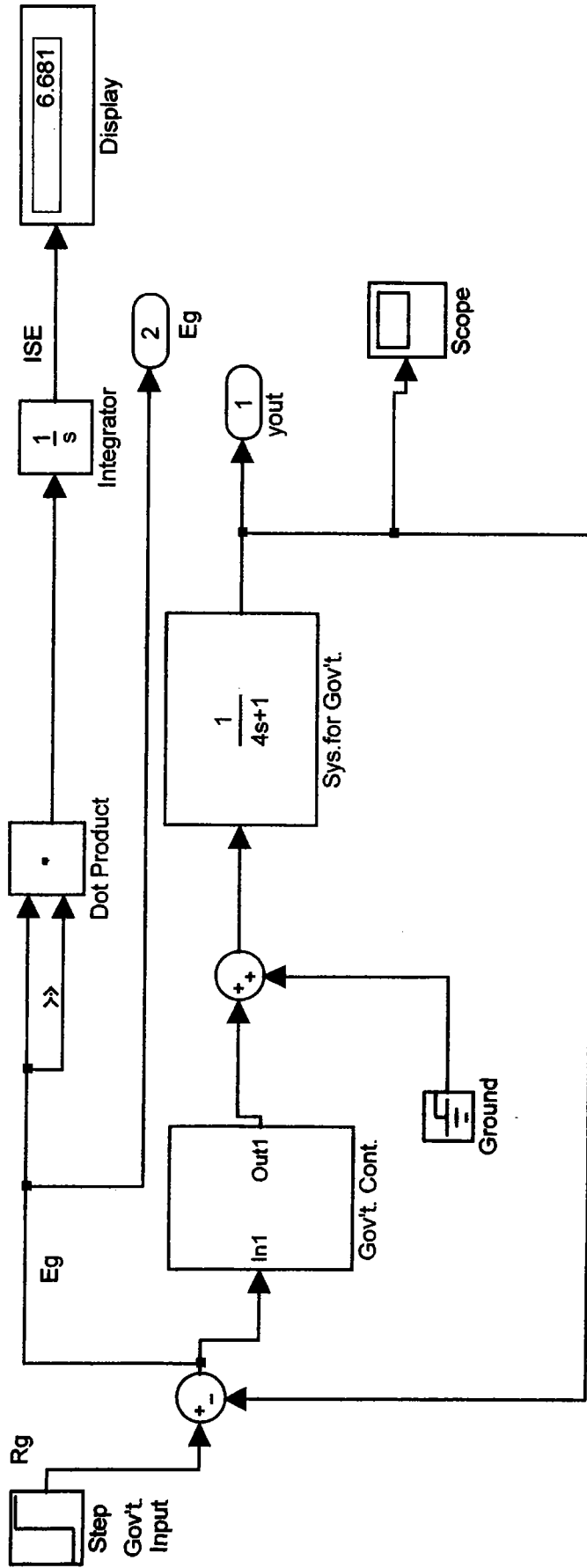

FIGURE 5 ISOLATED GOVERNMENT LOOP

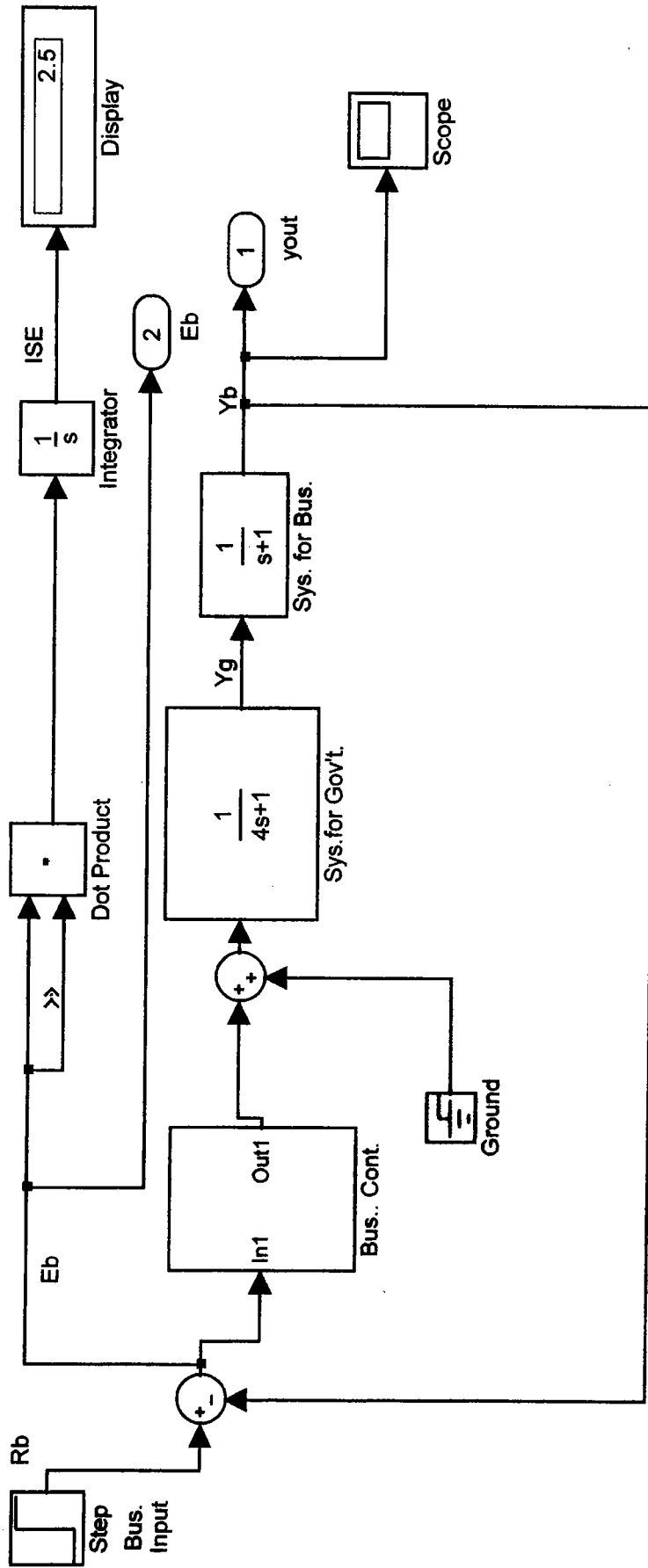

FIGURE 6 ISOLATED BUSINESS LOOP

Step2

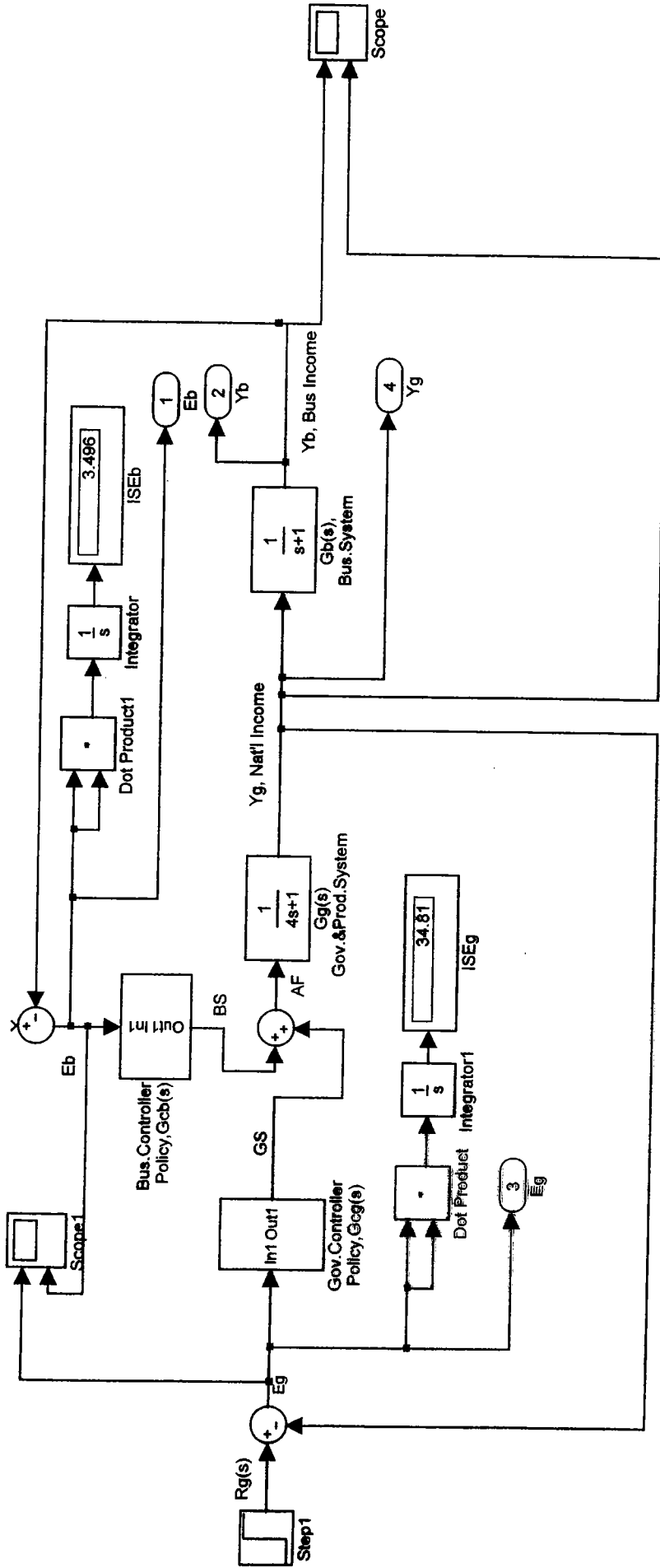
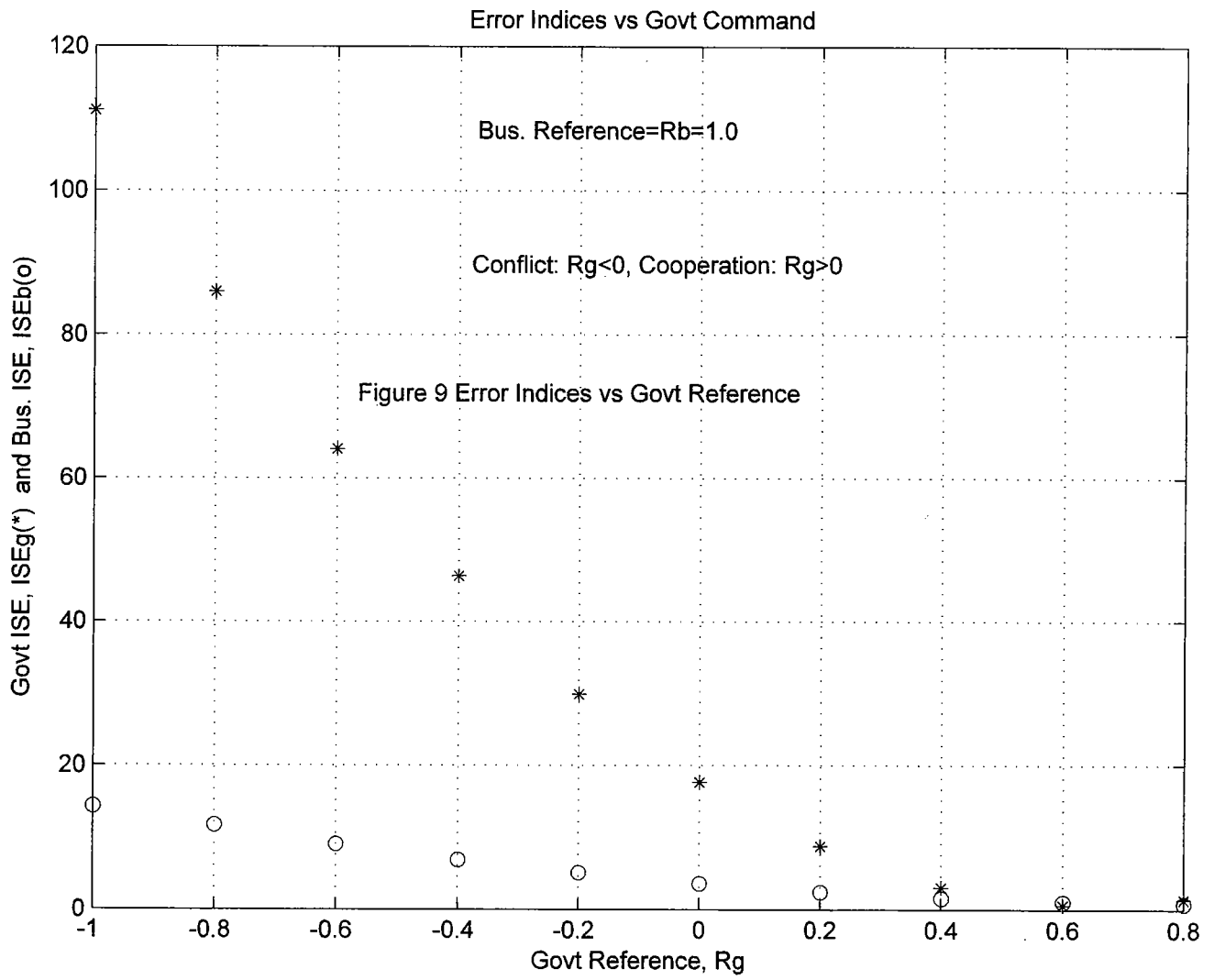

FIGURE 7 ZERO SIGNAL INJECTION FROM BUSINESS WITH SYSTEM MODIFICATION

AF=Available Funds

GS(s)=Gov't Spending

BS= Bus. Spending



Error Indices vs Business Command

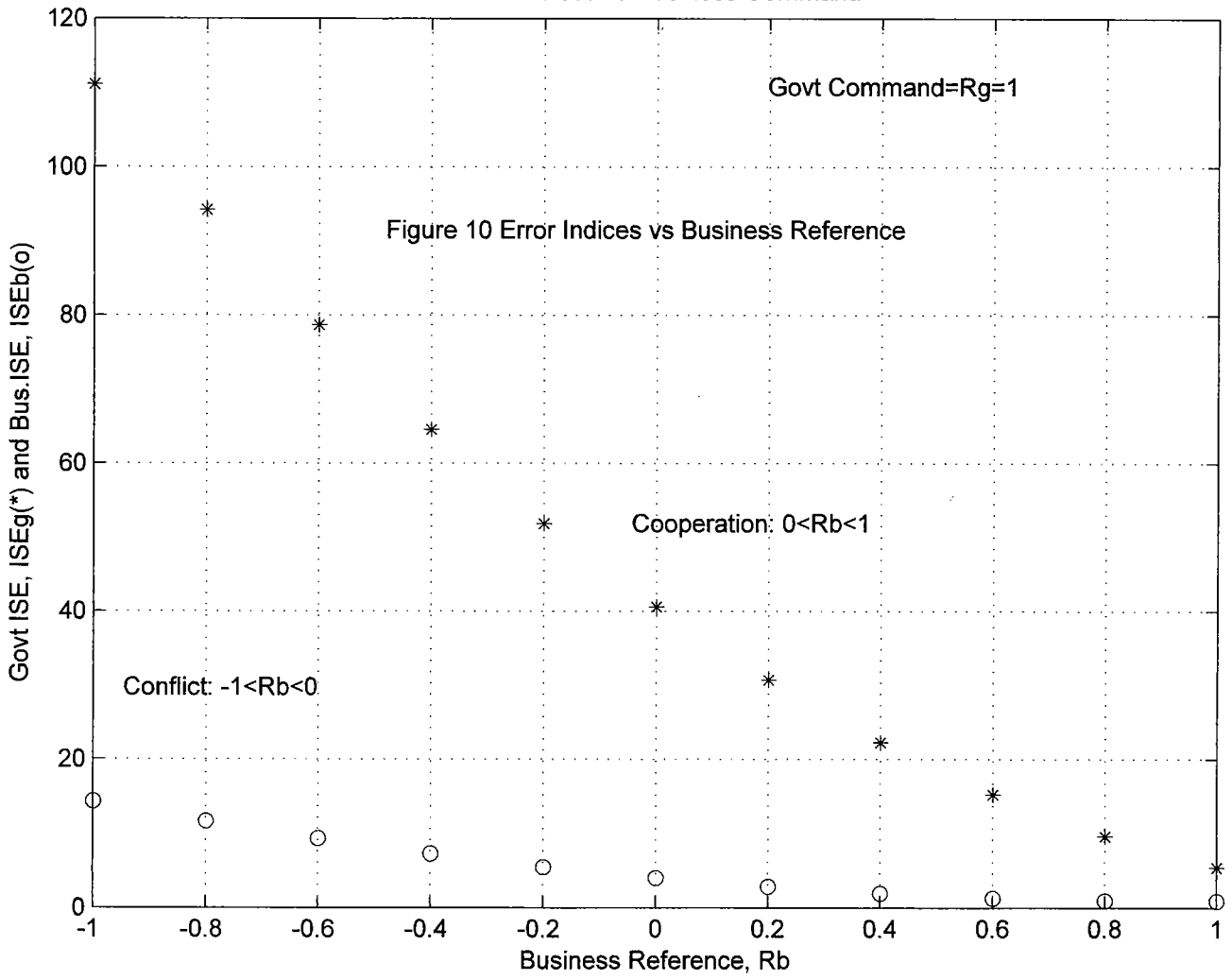

The National Economy as an Example of Control Under Conflict/Cooperation- A Simulation Approach

Robert L. Drake, Ph.D., P.E.
Department of Electrical and Computer Engineering
Christian Brothers University
Memphis, Tennessee
rdrake@cbu.edu

BACKGROUND

The work reported here is the result of teaching a course entitled ECE 488 Modeling and Simulation in Engineering Problems. This course is offered to students in both engineering and non-engineering. All students are required to simulate several dynamic systems during the semester at least one of which must be socio-political-economic (SPE) in nature. As instructor of the course, the writer chose the initial model of the national economy as an example of SPE systems to present to the class. This model was taken from reference [1] initially, and then as discussion progressed “refinements” were added. One of these refinements were reported in an earlier paper [2], where additional work suggested includes that of possible conflicts between the goals of government and the goals of business. The work reported here is the first attempt of the writer to approach that problem.

MODEL

The model hypothesized in this work is shown in the block diagram of Figure 1. Although inspired by the model suggested in reference [1], the model differs in several respects, among which are the inclusion of business investment as a separate input of the two-input system, identification of separate decision-making (controllers) for government and business, identification of different performance indices for government and business, and inclusion of two distinct outputs from the system. The inputs to the system are shown as business reference input (R_b) and the government reference input (R_g). The outputs from the system are shown as the national income level (Y_g) and the business income level (Y_b).

Figure 2 shows the identification of two performance indices chosen in this study. The performance index for government is based on the error, or difference, between the desired change in national income level and the measured change, E_g . In this case the integral squared value of this error is taken as the performance index. For business the error, or difference, is E_b as measured by the desired change in business income and the actual value. Again, the integral squared value of this error is used as the performance index.

Figure 3 shows the proportional plus integral (PI) controller chosen for the government controller. The controller constants were chosen to provide critical damping for the isolated government system. The government system is defined as isolated when the business input is set to zero (command for no change) and the business spending signal (BS) is set to zero. The simulation of the isolated government loop is shown in Figure 5 along with the indicated integral square error (ISE_g) of 6.681 for the unit step response which can be checked with theory for this particular index of performance. Figure 4 shows the PI controller chosen for the isolated business loop and Figure 6 shows the simulation result for this case where the ISE_b is 2.5 which also is checked by application of theory.

In Figure 1 the system representing government and production operations is shown with time constant of 4 time units and “dc” gain of 1. The system representing business operations is shown with time constant of 1 time unit and gain of 1.

DEFINITION OF CONFLICT AND COOPERATION

In Figure 2 the goal of government is to reduce as much as possible the performance index defined in this case as the integral square of the error signal E_g shown as ISE_g. The goal of business is to reduce ISE_b as much as possible. In the model shown, there is coupling between the government loop and the business loop with the result that propagation of signals in one loop affects the operation of the second loop. In the context of this work, conflict is defined to exist if the effect of the first loop upon the second loop is such that the performance index of the second is worsened, or increased in this case where the goal is to decrease the ISE. Similarly, cooperation is defined to exist if the coupling effect improves the performance index.

Simulation makes obvious that conflict and cooperation can exist because of signal injection or because of system modification without signal injection, or both. In Figure 7 no signal is injected by the business system, but because of the presence of the business feedback loop the government performance index ISE_g is increased by a factor of (34.81/6.68), or 5.2 to 1. By the definition above, conflict exists. On the other hand, in Figure 8 signal injection at the business reference input R_b along with the feedback in the business loop results in ISE_g increase by a factor of (132.3/6.68), or 19.8 to 1. Conflict from signal injection in this case results from the opposite signs in the reference input to the government loop and reference input to the business loop.

ADDITIONAL SIMULATION RESULTS

Additional simulation results are shown in Figures 9 and 10. Figure 9 shows the variation of the performance indices ISE_g and ISE_b with government reference R_g with business reference R_b held constant at unity. By the definitions above for cooperation and conflict,

cooperation increases as R_g varies from 0 to 1 and conflict increases as R_g varies from 0 to -1. There is a rapid increase in the error indices as the conflict increases and a rapid decrease in the error indices as the cooperation increases. Figure 10 shows the variation of the error indices as a function of the business reference R_b with the government reference held constant at unity. Again, there is a rapid increase in error indices as conflict increases and a rapid decrease in error indices as cooperation increases.

SUMMARY AND CONCLUSIONS

(1) Conflict may be defined by the actions of one participant, say business, tending to increase the performance index being minimized by the second participant, say government. Cooperation may be defined as existing when the actions of one of the participants tends to reduce the performance index being minimized by the second participant.

(2) Cooperation/conflict may result from either signal injection or from system modification, or both.

FUTURE WORK

(1) The effects of consumers should be added to the model. With three participants present, the possibility of joint cooperation/conflict arises. Include the effect of foreign investment.

(2) Practical data and reasonable scaling limits should be added. This probably requires participation of personnel with backgrounds in business and economics.

(3) Re-phrase the problem in terms of state variables and vector-matrix operations. Use modern control theory to re-design the controllers. Consider the possibility of decoupling output except from one input.

FINAL COMMENTS

(1) This is a work in progress.

(2) Results and conclusions, although believed to be original, are preliminary and should be considered as such.

REFERENCES

- [1] S.M. Shinnars, Modern Control Theory and Application, Reading, MA, Addison-Wesley, 1972.
- [2] R.L. Drake, "Do Checks and Balances Contribute to Cycles in the Economy?", MAESC 2003, Christian Brothers University, Memphis, TN, May 15, 2003.

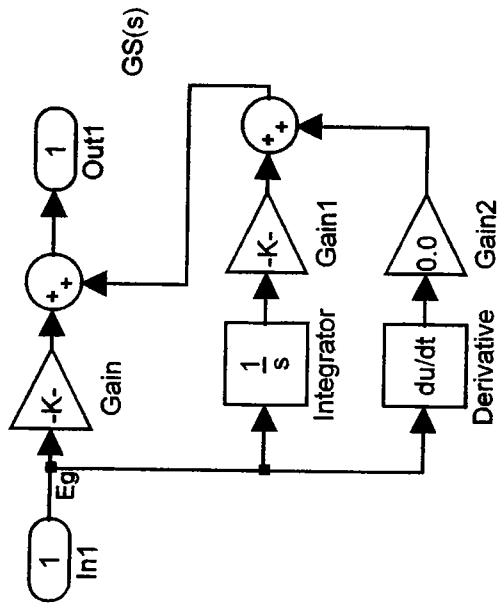

FIGURE 3 GOVERNMENT PI CONTROLLER

$K_p=0.1716$

$K_i=0.0858$

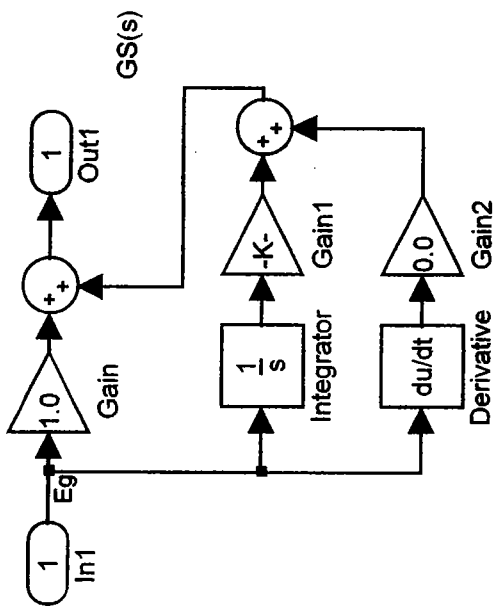

FIGURE 4 BUSINESS PI CONTROLLER

$Kp=1.0$
 $Ki=0.25$

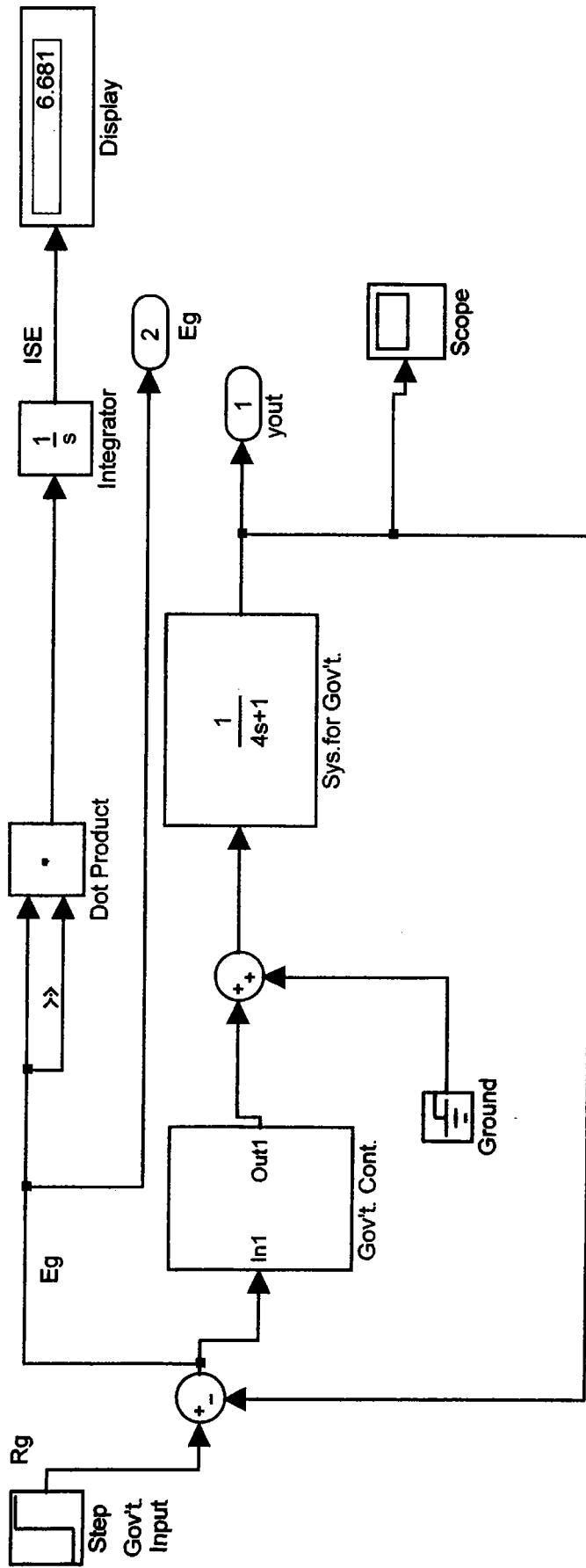

FIGURE 5 ISOLATED GOVERNMENT LOOP

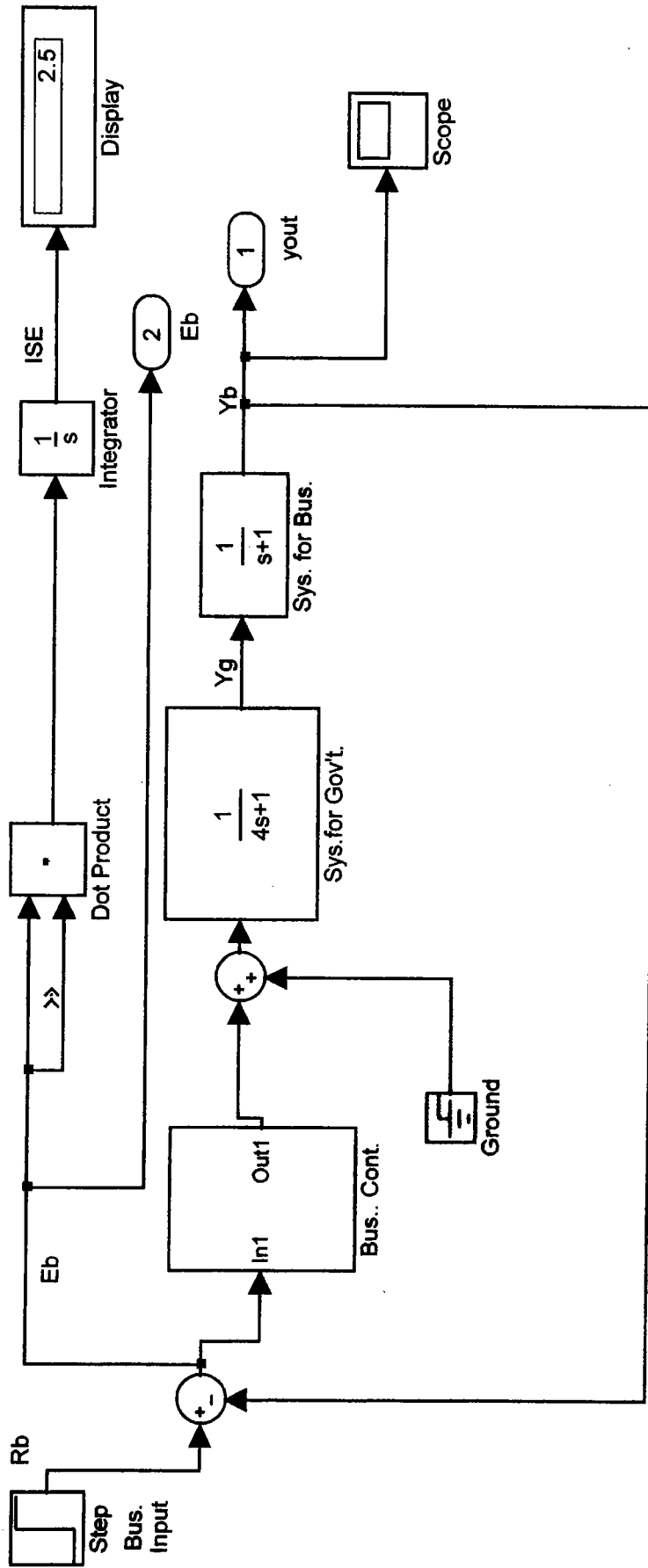

FIGURE 6 ISOLATED BUSINESS LOOP

Step2

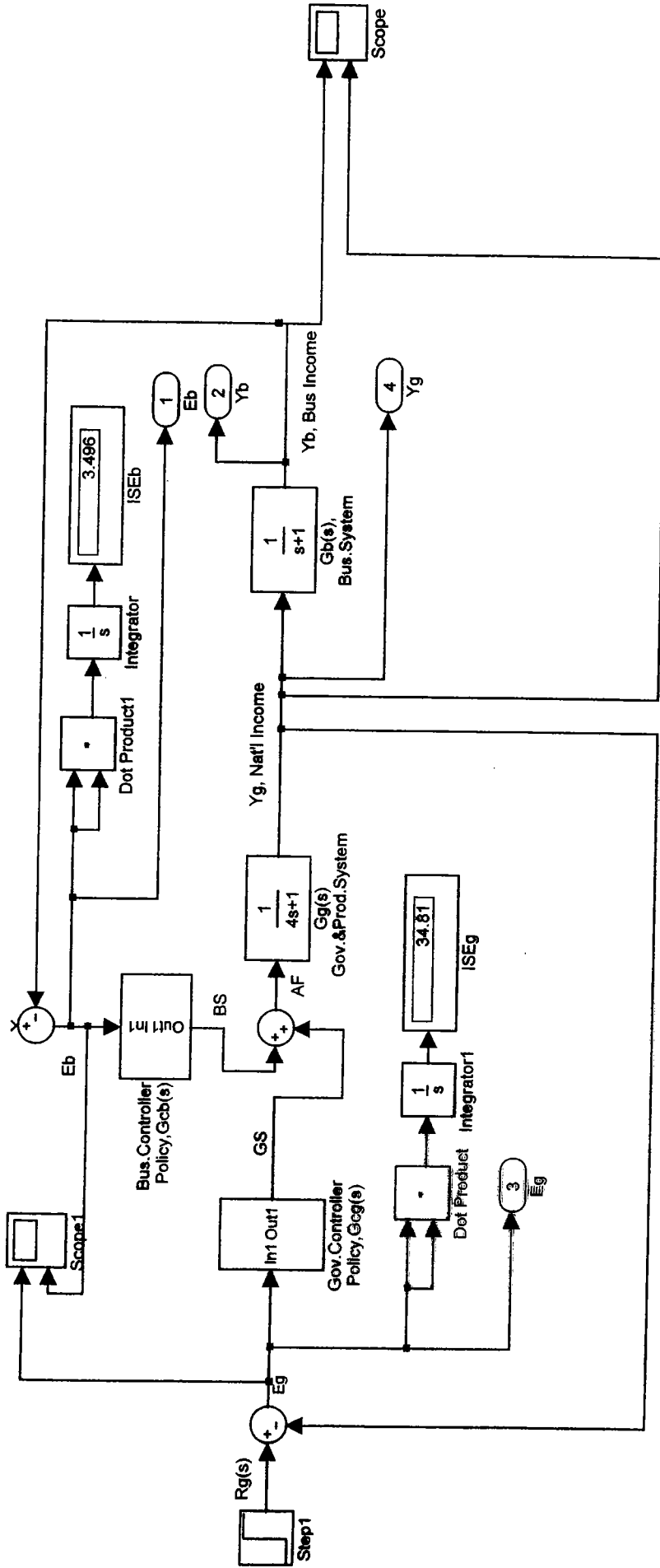
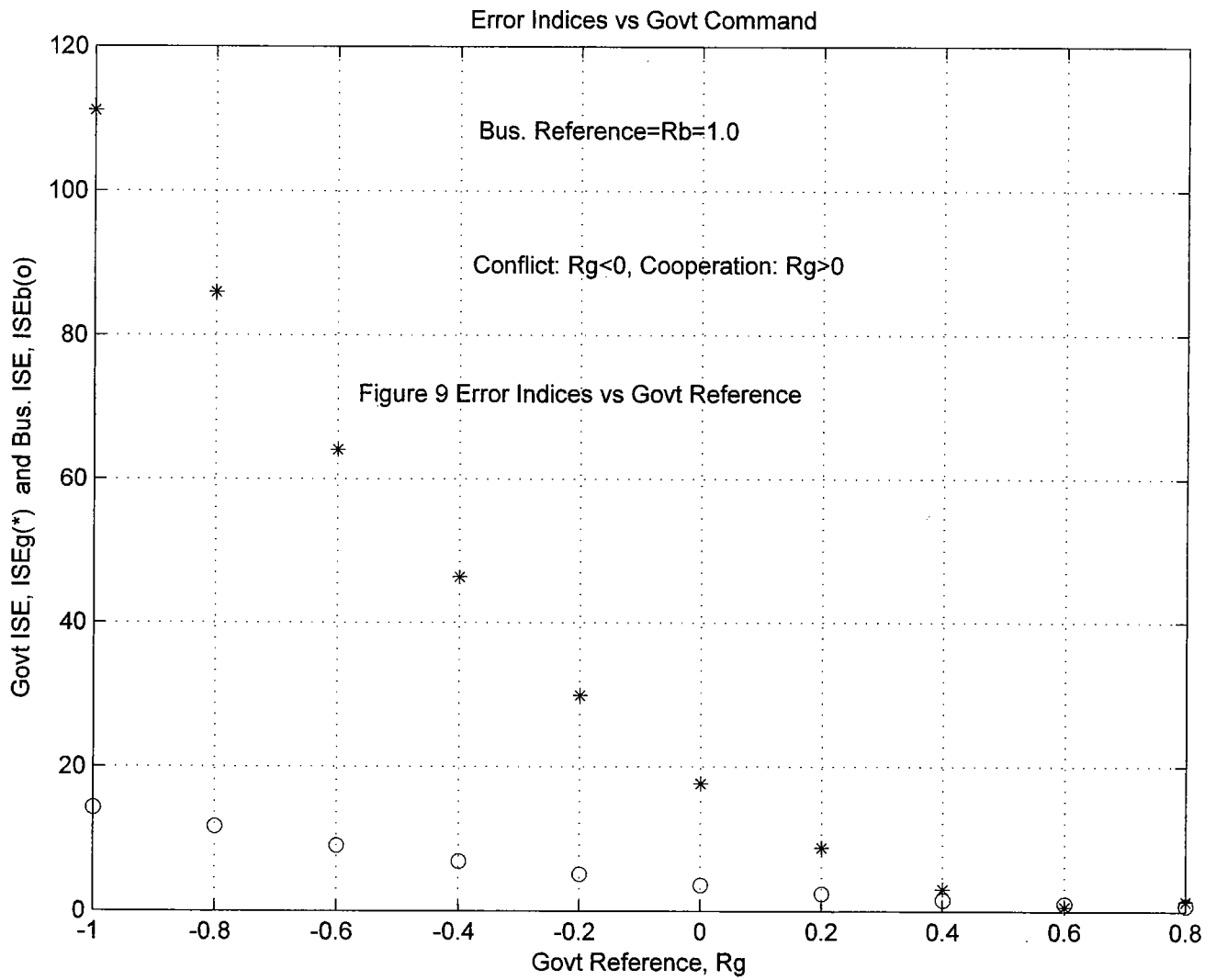

FIGURE 7 ZERO SIGNAL INJECTION FROM BUSINESS WITH SYSTEM MODIFICATION

AF=Available Funds

GS(s)=Gov't Spending

BS= Bus. Spending



Error Indices vs Business Command

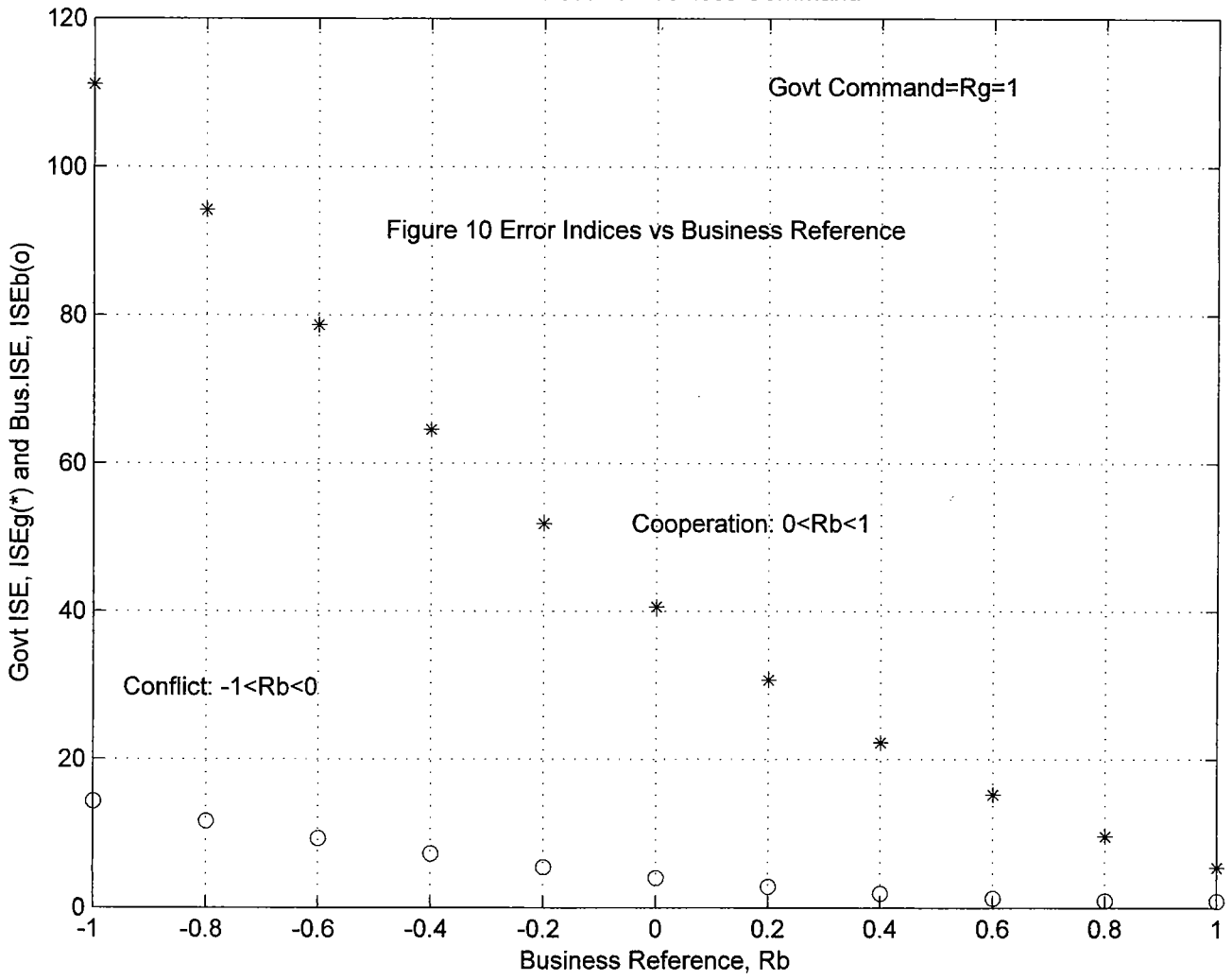

The National Economy as an Example of Control Under Conflict/Cooperation- A Simulation Approach

Robert L. Drake, Ph.D., P.E.
Department of Electrical and Computer Engineering
Christian Brothers University
Memphis, Tennessee
rdrake@cbu.edu

BACKGROUND

The work reported here is the result of teaching a course entitled ECE 488 Modeling and Simulation in Engineering Problems. This course is offered to students in both engineering and non-engineering. All students are required to simulate several dynamic systems during the semester at least one of which must be socio-political-economic (SPE) in nature. As instructor of the course, the writer chose the initial model of the national economy as an example of SPE systems to present to the class. This model was taken from reference [1] initially, and then as discussion progressed “refinements” were added. One of these refinements were reported in an earlier paper [2], where additional work suggested includes that of possible conflicts between the goals of government and the goals of business. The work reported here is the first attempt of the writer to approach that problem.

MODEL

The model hypothesized in this work is shown in the block diagram of Figure 1. Although inspired by the model suggested in reference [1], the model differs in several respects, among which are the inclusion of business investment as a separate input of the two-input system, identification of separate decision-making (controllers) for government and business, identification of different performance indices for government and business, and inclusion of two distinct outputs from the system. The inputs to the system are shown as business reference input (R_b) and the government reference input (R_g). The outputs from the system are shown as the national income level (Y_g) and the business income level (Y_b).

Figure 2 shows the identification of two performance indices chosen in this study. The performance index for government is based on the error, or difference, between the desired change in national income level and the measured change, E_g . In this case the integral squared value of this error is taken as the performance index. For business the error, or difference, is E_b as measured by the desired change in business income and the actual value. Again, the integral squared value of this error is used as the performance index.

Figure 3 shows the proportional plus integral (PI) controller chosen for the government controller. The controller constants were chosen to provide critical damping for the isolated government system. The government system is defined as isolated when the business input is set to zero (command for no change) and the business spending signal (BS) is set to zero. The simulation of the isolated government loop is shown in Figure 5 along with the indicated integral square error (ISE_g) of 6.681 for the unit step response which can be checked with theory for this particular index of performance. Figure 4 shows the PI controller chosen for the isolated business loop and Figure 6 shows the simulation result for this case where the ISE_b is 2.5 which also is checked by application of theory.

In Figure 1 the system representing government and production operations is shown with time constant of 4 time units and “dc” gain of 1. The system representing business operations is shown with time constant of 1 time unit and gain of 1.

DEFINITION OF CONFLICT AND COOPERATION

In Figure 2 the goal of government is to reduce as much as possible the performance index defined in this case as the integral square of the error signal E_g shown as ISE_g. The goal of business is to reduce ISE_b as much as possible. In the model shown, there is coupling between the government loop and the business loop with the result that propagation of signals in one loop affects the operation of the second loop. In the context of this work, conflict is defined to exist if the effect of the first loop upon the second loop is such that the performance index of the second is worsened, or increased in this case where the goal is to decrease the ISE. Similarly, cooperation is defined to exist if the coupling effect improves the performance index.

Simulation makes obvious that conflict and cooperation can exist because of signal injection or because of system modification without signal injection, or both. In Figure 7 no signal is injected by the business system, but because of the presence of the business feedback loop the government performance index ISE_g is increased by a factor of (34.81/6.68), or 5.2 to 1. By the definition above, conflict exists. On the other hand, in Figure 8 signal injection at the business reference input R_b along with the feedback in the business loop results in ISE_g increase by a factor of (132.3/6.68), or 19.8 to 1. Conflict from signal injection in this case results from the opposite signs in the reference input to the government loop and reference input to the business loop.

ADDITIONAL SIMULATION RESULTS

Additional simulation results are shown in Figures 9 and 10. Figure 9 shows the variation of the performance indices ISE_g and ISE_b with government reference R_g with business reference R_b held constant at unity. By the definitions above for cooperation and conflict,

cooperation increases as R_g varies from 0 to 1 and conflict increases as R_g varies from 0 to -1. There is a rapid increase in the error indices as the conflict increases and a rapid decrease in the error indices as the cooperation increases. Figure 10 shows the variation of the error indices as a function of the business reference R_b with the government reference held constant at unity. Again, there is a rapid increase in error indices as conflict increases and a rapid decrease in error indices as cooperation increases.

SUMMARY AND CONCLUSIONS

(1) Conflict may be defined by the actions of one participant, say business, tending to increase the performance index being minimized by the second participant, say government. Cooperation may be defined as existing when the actions of one of the participants tends to reduce the performance index being minimized by the second participant.

(2) Cooperation/conflict may result from either signal injection or from system modification, or both.

FUTURE WORK

(1) The effects of consumers should be added to the model. With three participants present, the possibility of joint cooperation/conflict arises. Include the effect of foreign investment.

(2) Practical data and reasonable scaling limits should be added. This probably requires participation of personnel with backgrounds in business and economics.

(3) Re-phrase the problem in terms of state variables and vector-matrix operations. Use modern control theory to re-design the controllers. Consider the possibility of decoupling output except from one input.

FINAL COMMENTS

(1) This is a work in progress.

(2) Results and conclusions, although believed to be original, are preliminary and should be considered as such.

REFERENCES

- [1] S.M. Shinnars, Modern Control Theory and Application, Reading, MA, Addison-Wesley, 1972.
- [2] R.L. Drake, "Do Checks and Balances Contribute to Cycles in the Economy?", MAESC 2003, Christian Brothers University, Memphis, TN, May 15, 2003.

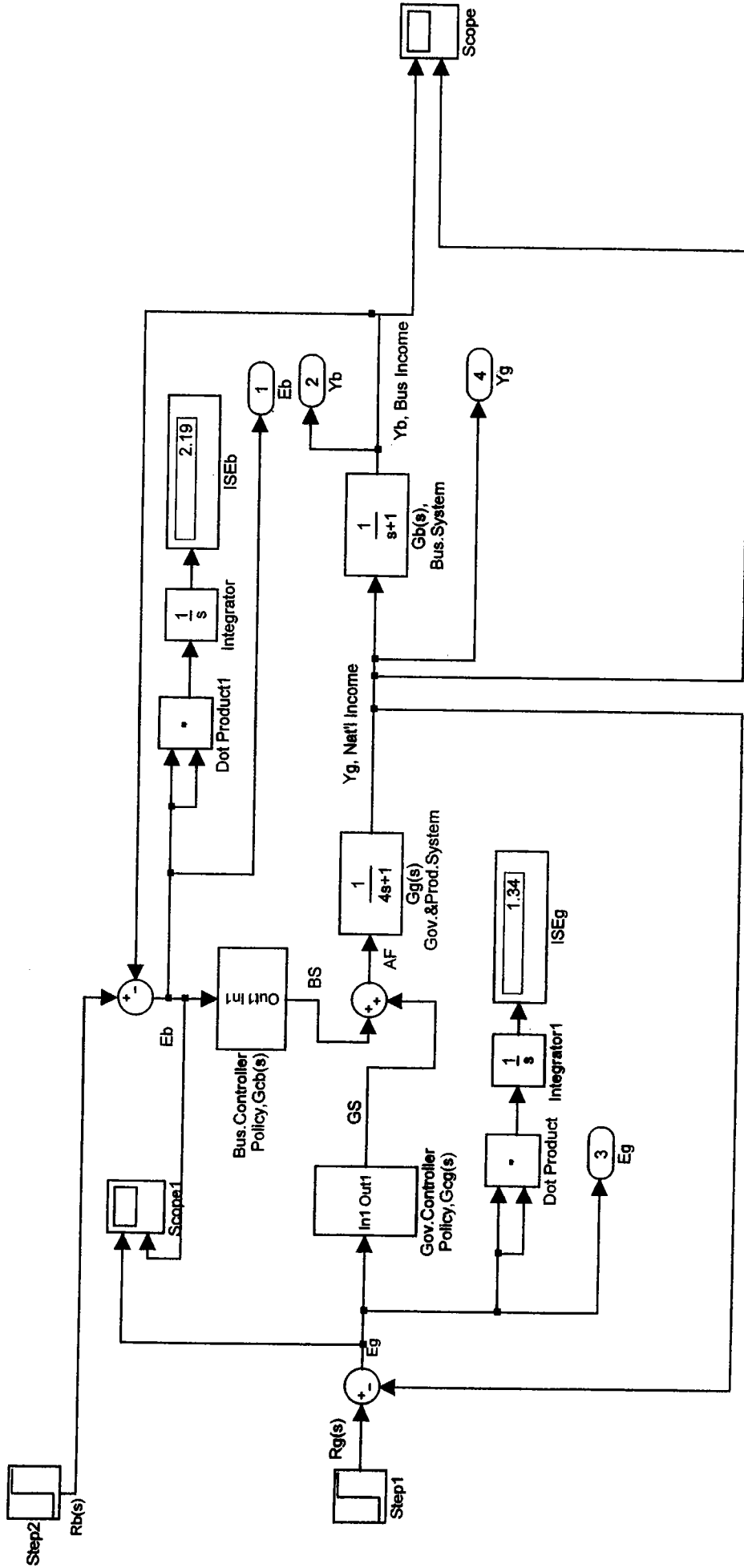

FIGURE 2 BLOCK DIAGRAM with VIRTUAL INSTRUMENTATION and COMPUTATION

AF=Available Funds
 GS(s)=Gov't Spending
 BS= Bus. Spending

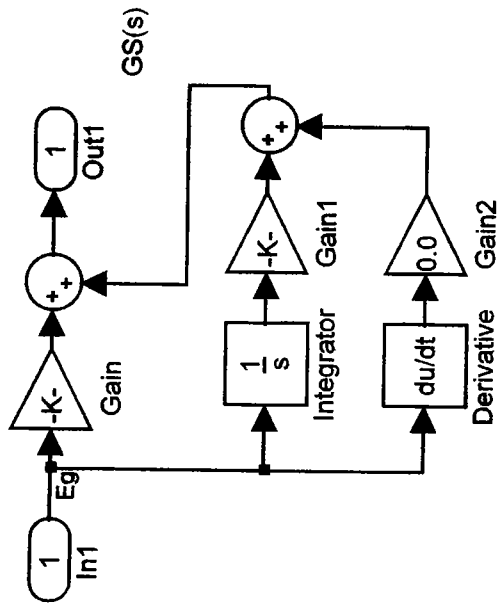

FIGURE 3 GOVERNMENT PI CONTROLLER

$K_p=0.1716$

$K_i=0.0858$

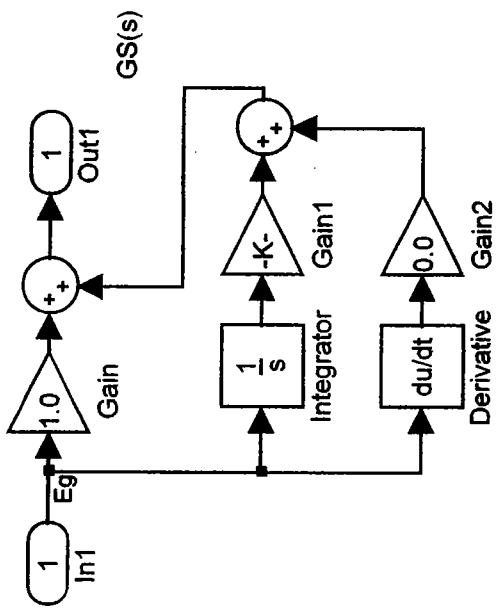

FIGURE 4 BUSINESS PI CONTROLLER

$Kp=1.0$
 $Ki=0.25$

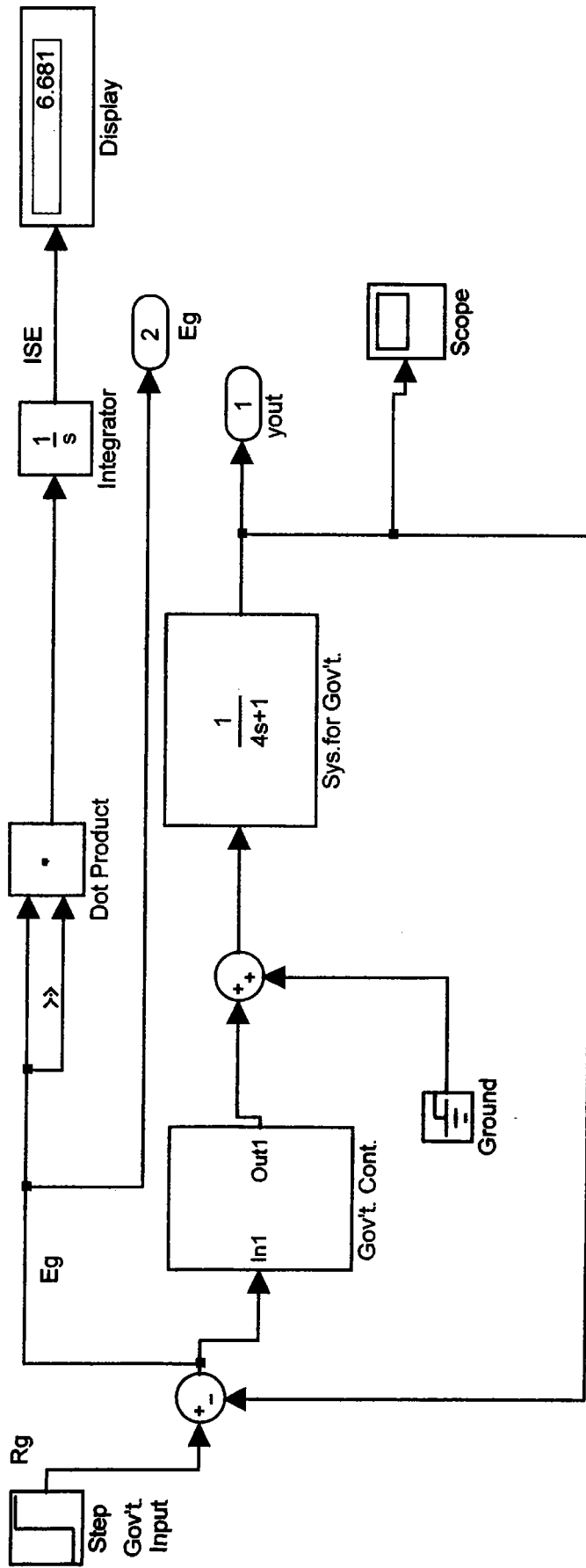

FIGURE 5 ISOLATED GOVERNMENT LOOP

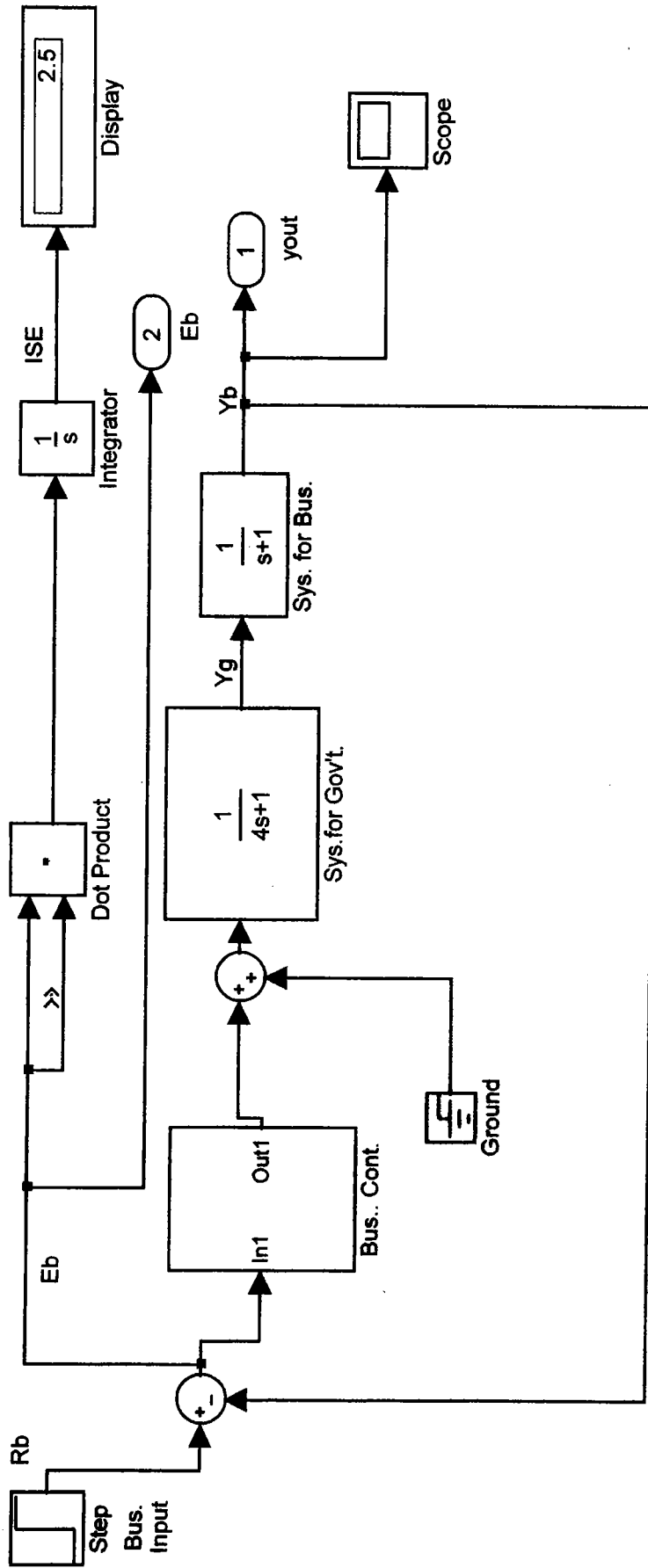

FIGURE 6 ISOLATED BUSINESS LOOP

Step2

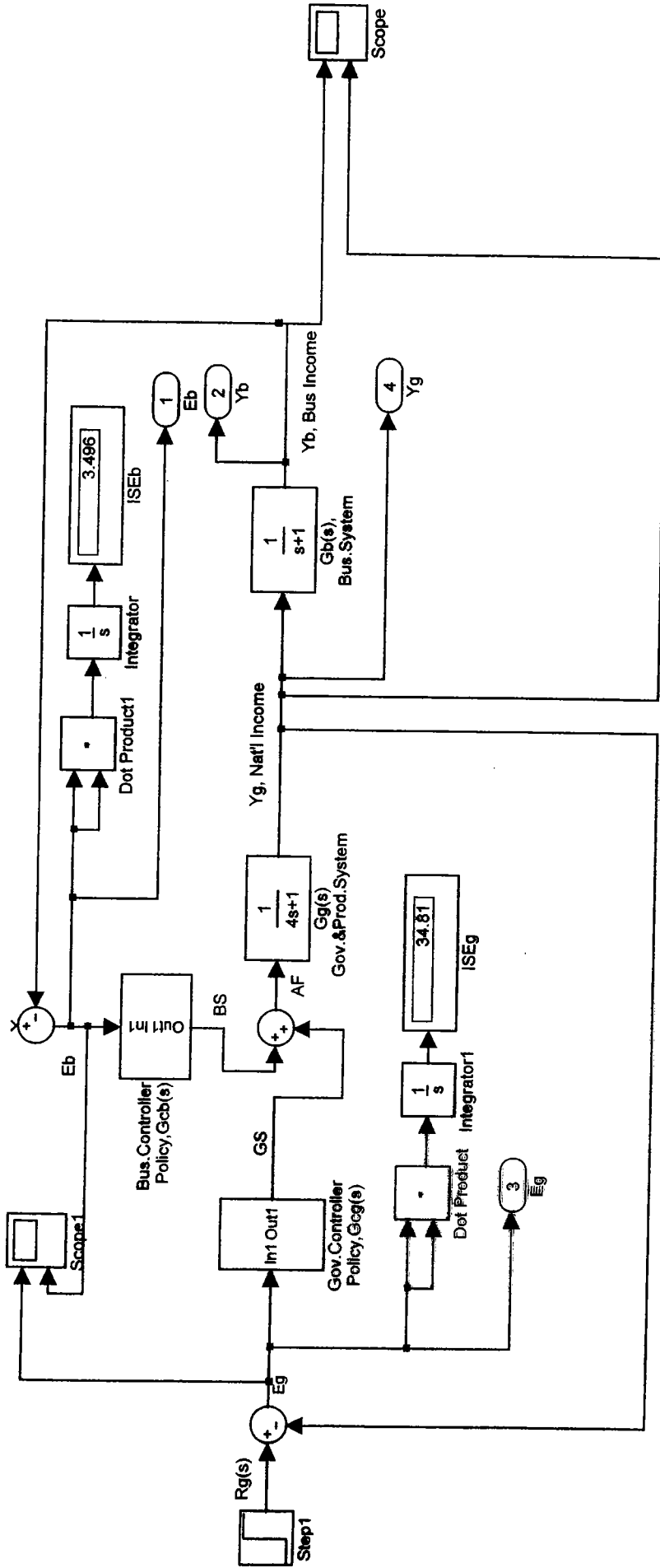
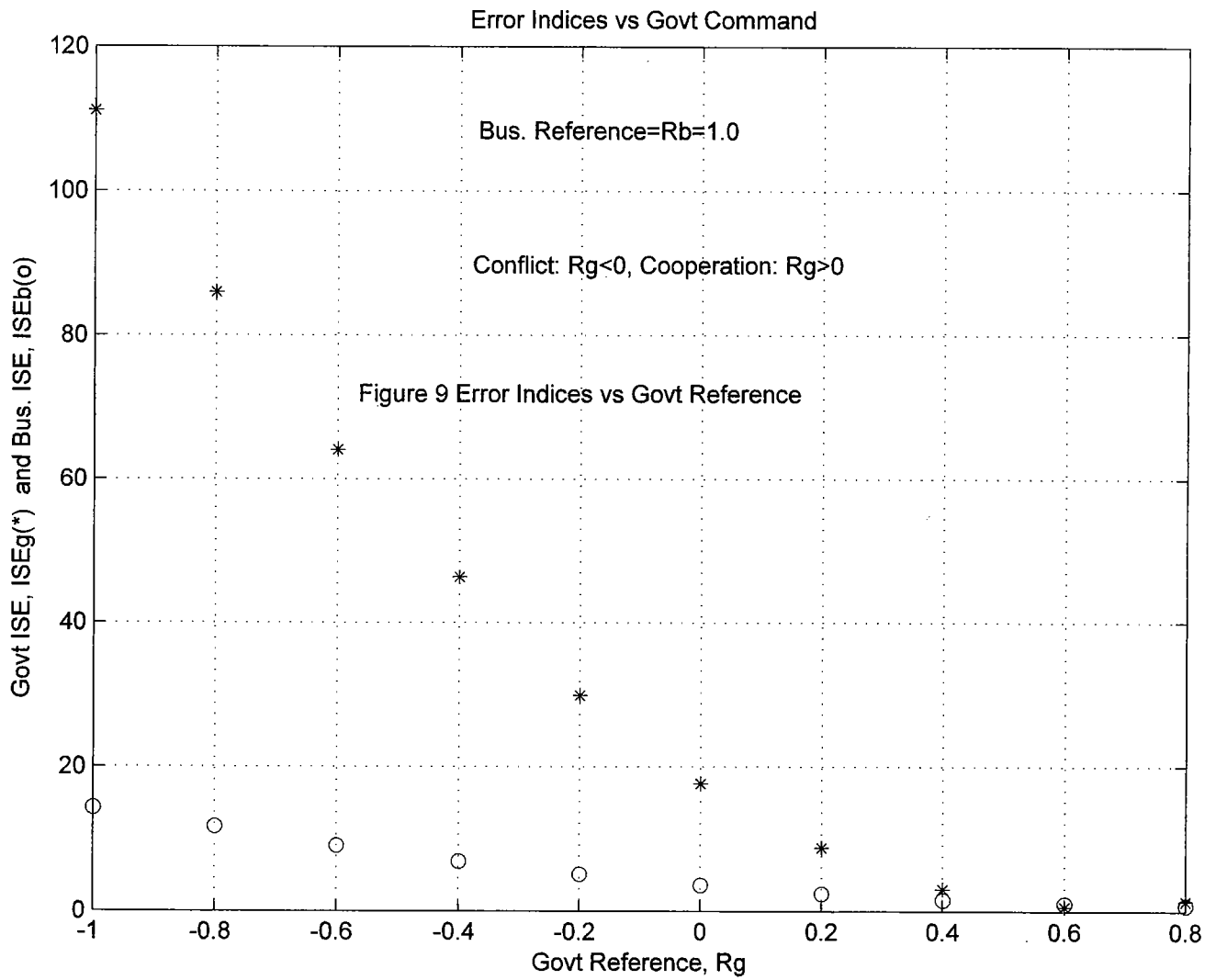

FIGURE 7 ZERO SIGNAL INJECTION FROM BUSINESS WITH SYSTEM MODIFICATION

AF=Available Funds

$G_b(s)$ =Gov't Spending

BS = Bus. Spending



Error Indices vs Business Command

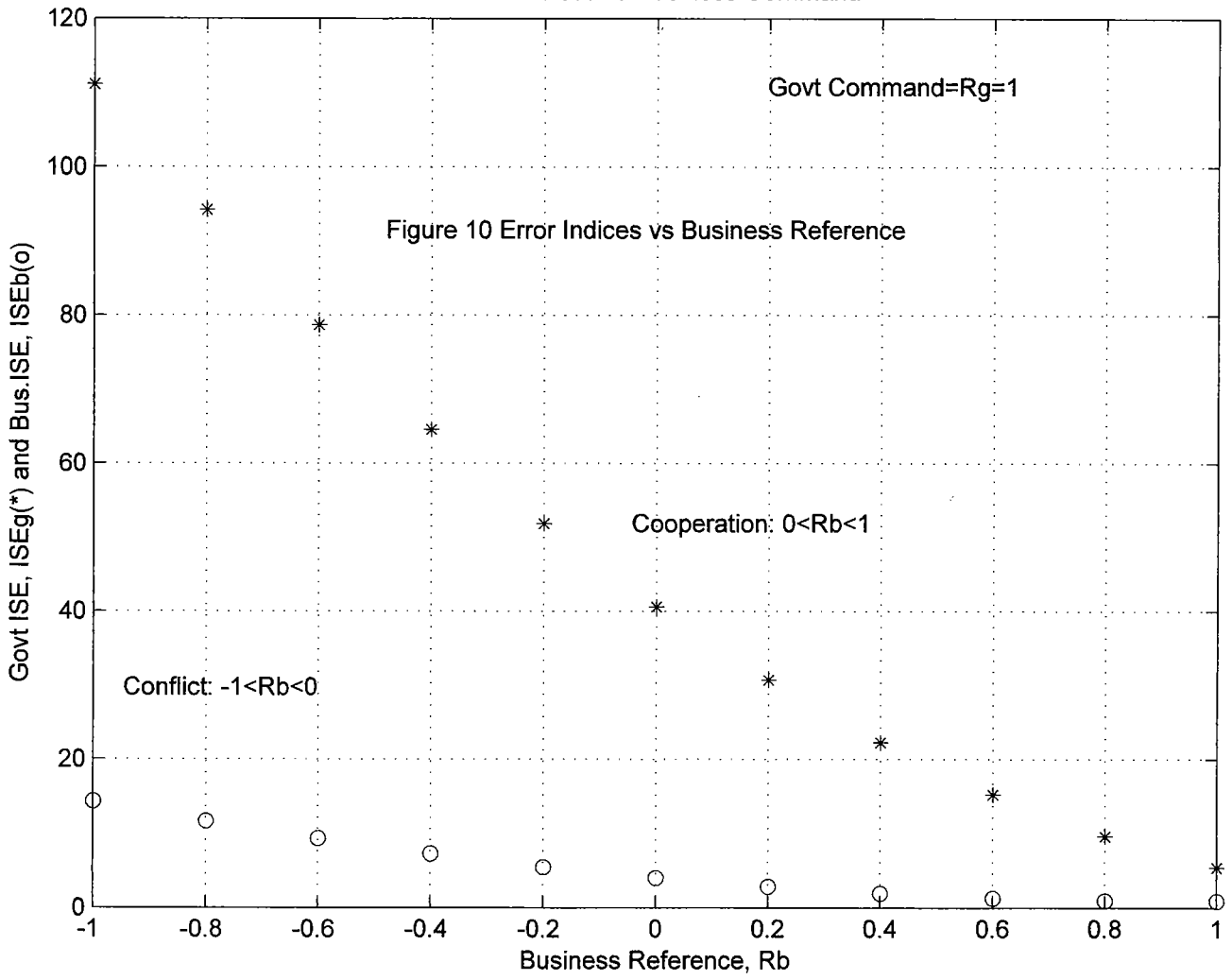

The National Economy as an Example of Control Under Conflict/Cooperation- A Simulation Approach

Robert L. Drake, Ph.D., P.E.
Department of Electrical and Computer Engineering
Christian Brothers University
Memphis, Tennessee
rdrake@cbu.edu

BACKGROUND

The work reported here is the result of teaching a course entitled ECE 488 Modeling and Simulation in Engineering Problems. This course is offered to students in both engineering and non-engineering. All students are required to simulate several dynamic systems during the semester at least one of which must be socio-political-economic (SPE) in nature. As instructor of the course, the writer chose the initial model of the national economy as an example of SPE systems to present to the class. This model was taken from reference [1] initially, and then as discussion progressed “refinements” were added. One of these refinements were reported in an earlier paper [2], where additional work suggested includes that of possible conflicts between the goals of government and the goals of business. The work reported here is the first attempt of the writer to approach that problem.

MODEL

The model hypothesized in this work is shown in the block diagram of Figure 1. Although inspired by the model suggested in reference [1], the model differs in several respects, among which are the inclusion of business investment as a separate input of the two-input system, identification of separate decision-making (controllers) for government and business, identification of different performance indices for government and business, and inclusion of two distinct outputs from the system. The inputs to the system are shown as business reference input (R_b) and the government reference input (R_g). The outputs from the system are shown as the national income level (Y_g) and the business income level (Y_b).

Figure 2 shows the identification of two performance indices chosen in this study. The performance index for government is based on the error, or difference, between the desired change in national income level and the measured change, E_g . In this case the integral squared value of this error is taken as the performance index. For business the error, or difference, is E_b as measured by the desired change in business income and the actual value. Again, the integral squared value of this error is used as the performance index.

Figure 3 shows the proportional plus integral (PI) controller chosen for the government controller. The controller constants were chosen to provide critical damping for the isolated government system. The government system is defined as isolated when the business input is set to zero (command for no change) and the business spending signal (BS) is set to zero. The simulation of the isolated government loop is shown in Figure 5 along with the indicated integral square error (ISE_g) of 6.681 for the unit step response which can be checked with theory for this particular index of performance. Figure 4 shows the PI controller chosen for the isolated business loop and Figure 6 shows the simulation result for this case where the ISE_b is 2.5 which also is checked by application of theory.

In Figure 1 the system representing government and production operations is shown with time constant of 4 time units and “dc” gain of 1. The system representing business operations is shown with time constant of 1 time unit and gain of 1.

DEFINITION OF CONFLICT AND COOPERATION

In Figure 2 the goal of government is to reduce as much as possible the performance index defined in this case as the integral square of the error signal E_g shown as ISE_g. The goal of business is to reduce ISE_b as much as possible. In the model shown, there is coupling between the government loop and the business loop with the result that propagation of signals in one loop affects the operation of the second loop. In the context of this work, conflict is defined to exist if the effect of the first loop upon the second loop is such that the performance index of the second is worsened, or increased in this case where the goal is to decrease the ISE. Similarly, cooperation is defined to exist if the coupling effect improves the performance index.

Simulation makes obvious that conflict and cooperation can exist because of signal injection or because of system modification without signal injection, or both. In Figure 7 no signal is injected by the business system, but because of the presence of the business feedback loop the government performance index ISE_g is increased by a factor of (34.81/6.68), or 5.2 to 1. By the definition above, conflict exists. On the other hand, in Figure 8 signal injection at the business reference input R_b along with the feedback in the business loop results in ISE_g increase by a factor of (132.3/6.68), or 19.8 to 1. Conflict from signal injection in this case results from the opposite signs in the reference input to the government loop and reference input to the business loop.

ADDITIONAL SIMULATION RESULTS

Additional simulation results are shown in Figures 9 and 10. Figure 9 shows the variation of the performance indices ISE_g and ISE_b with government reference R_g with business reference R_b held constant at unity. By the definitions above for cooperation and conflict,

cooperation increases as R_g varies from 0 to 1 and conflict increases as R_g varies from 0 to -1. There is a rapid increase in the error indices as the conflict increases and a rapid decrease in the error indices as the cooperation increases. Figure 10 shows the variation of the error indices as a function of the business reference R_b with the government reference held constant at unity. Again, there is a rapid increase in error indices as conflict increases and a rapid decrease in error indices as cooperation increases.

SUMMARY AND CONCLUSIONS

(1) Conflict may be defined by the actions of one participant, say business, tending to increase the performance index being minimized by the second participant, say government. Cooperation may be defined as existing when the actions of one of the participants tends to reduce the performance index being minimized by the second participant.

(2) Cooperation/conflict may result from either signal injection or from system modification, or both.

FUTURE WORK

(1) The effects of consumers should be added to the model. With three participants present, the possibility of joint cooperation/conflict arises. Include the effect of foreign investment.

(2) Practical data and reasonable scaling limits should be added. This probably requires participation of personnel with backgrounds in business and economics.

(3) Re-phrase the problem in terms of state variables and vector-matrix operations. Use modern control theory to re-design the controllers. Consider the possibility of decoupling output except from one input.

FINAL COMMENTS

(1) This is a work in progress.

(2) Results and conclusions, although believed to be original, are preliminary and should be considered as such.

REFERENCES

- [1] S.M. Shinnars, Modern Control Theory and Application, Reading, MA, Addison-Wesley, 1972.
- [2] R.L. Drake, "Do Checks and Balances Contribute to Cycles in the Economy?", MAESC 2003, Christian Brothers University, Memphis, TN, May 15, 2003.

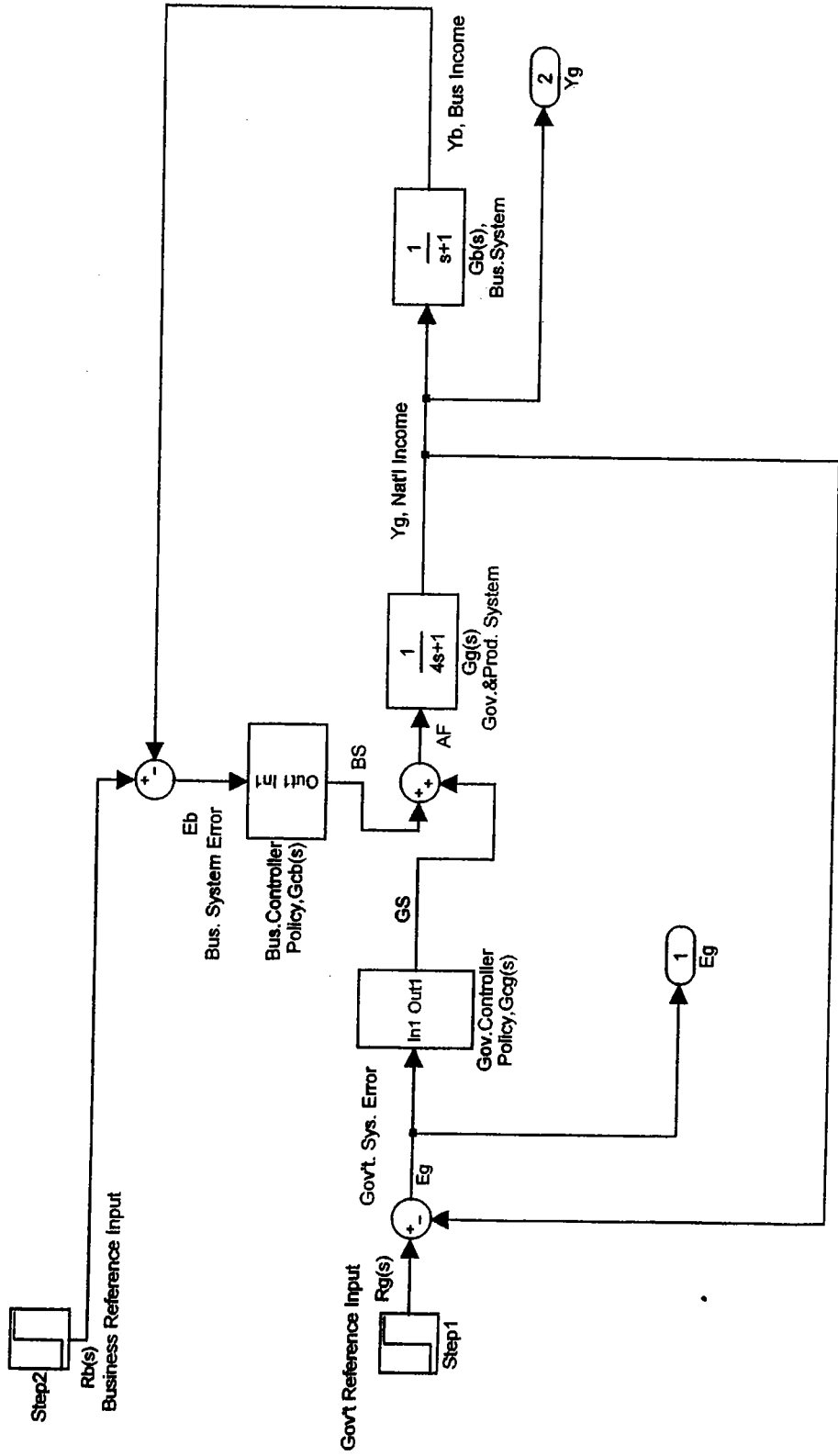

FIGURE 1 BLOCK DIAGRAM

AF=Available Funds
 GS(s)=Gov't Spending
 BS= Bus. Spending

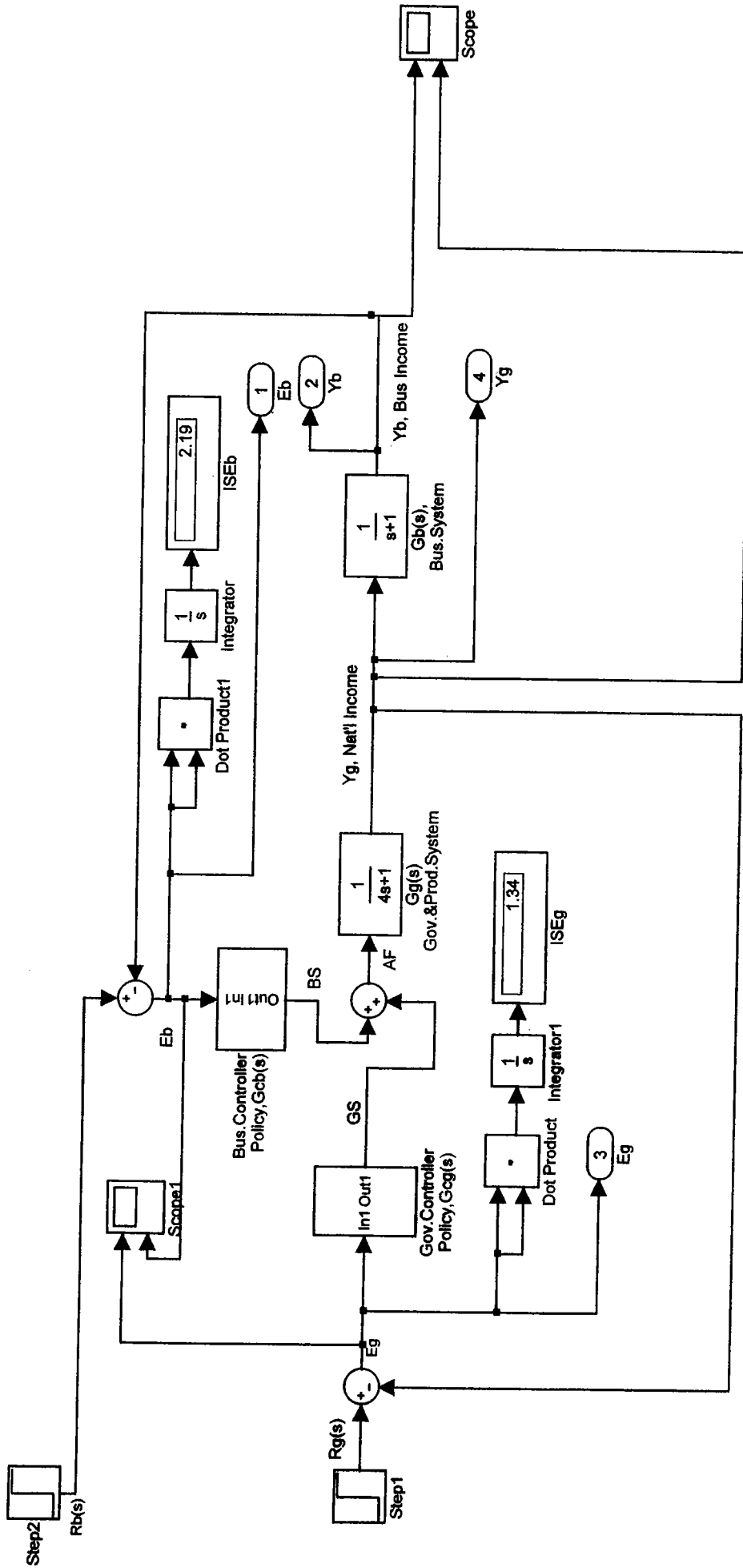

FIGURE 2 BLOCK DIAGRAM with VIRTUAL INSTRUMENTATION and COMPUTATION

AF=Available Funds
 GS(s)=Gov't Spending
 BS= Bus. Spending

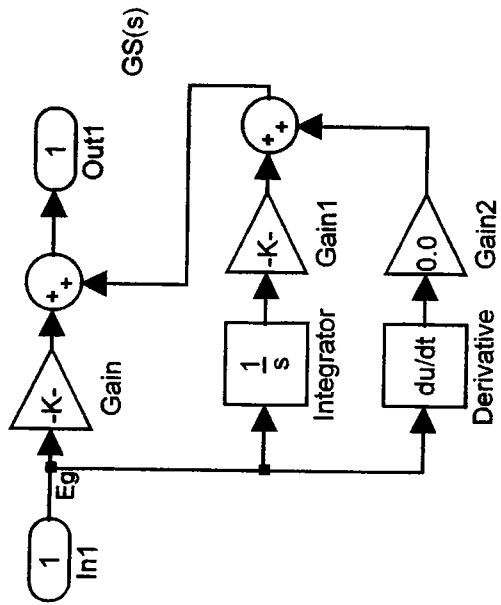

FIGURE 3 GOVERNMENT PI CONTROLLER

Kp=0.1716

Ki=0.0858

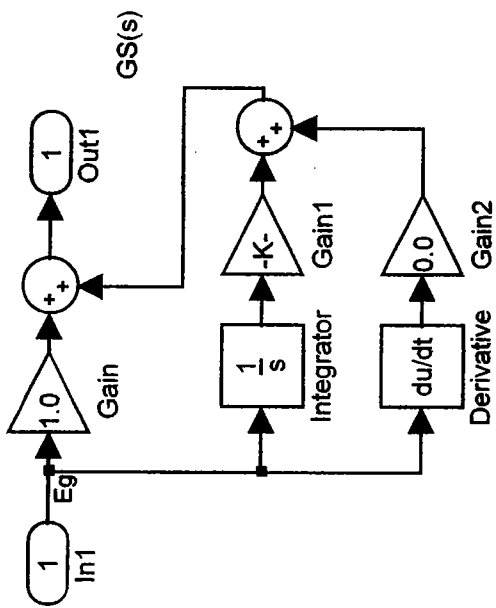

FIGURE 4 BUSINESS PI CONTROLLER

$Kp=1.0$
 $Ki=0.25$

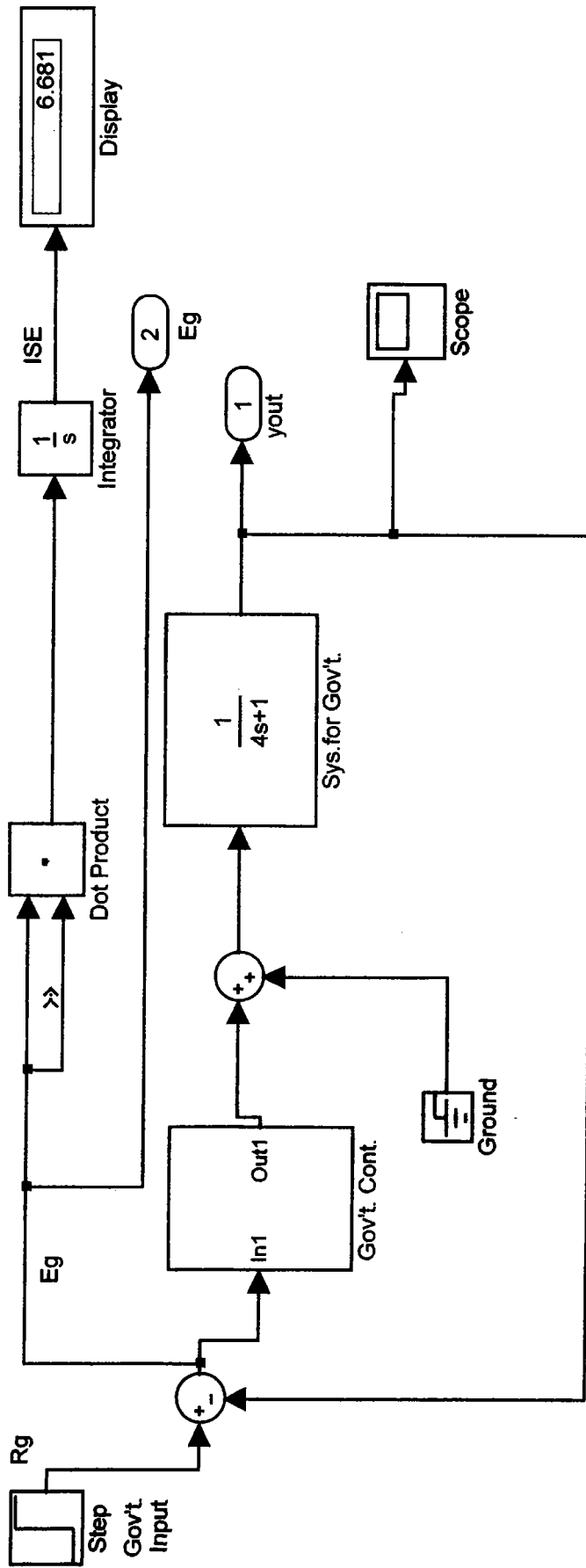

FIGURE 5 ISOLATED GOVERNMENT LOOP

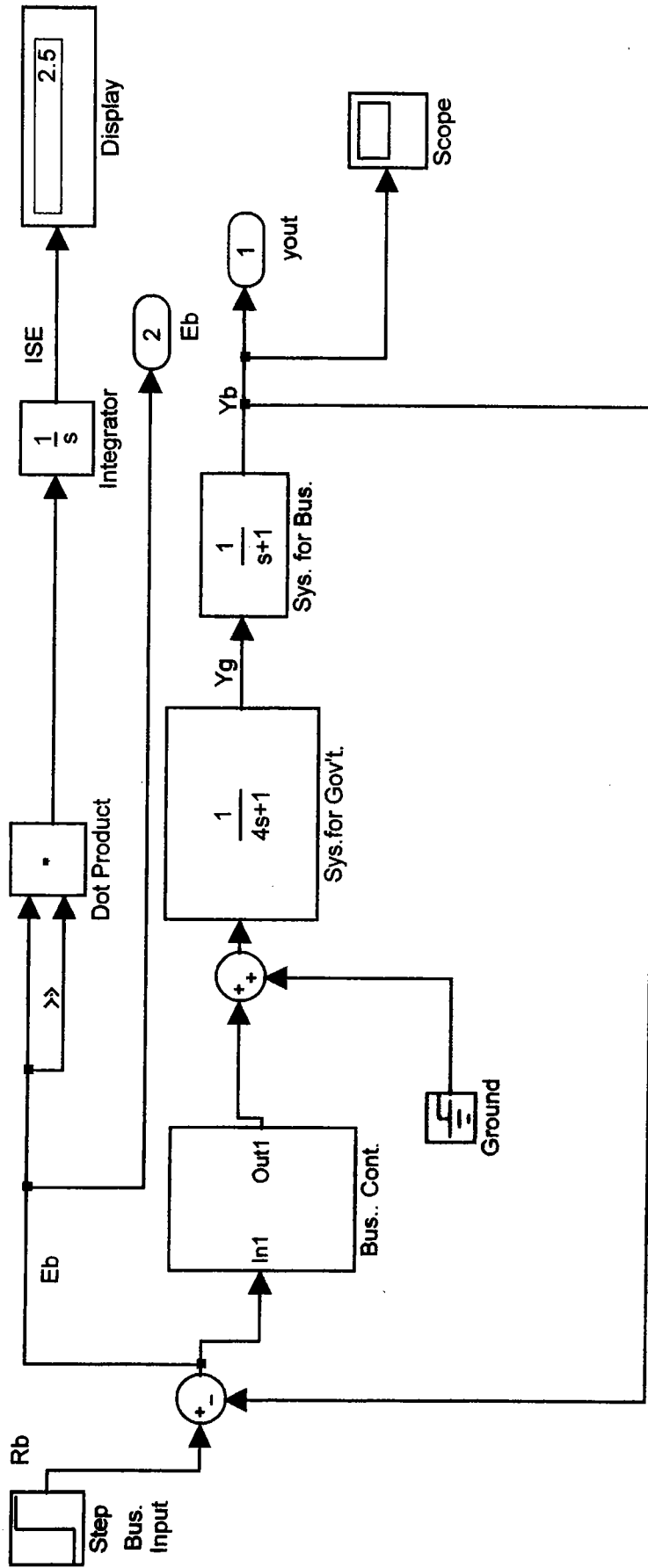

FIGURE 6 ISOLATED BUSINESS LOOP

Step2

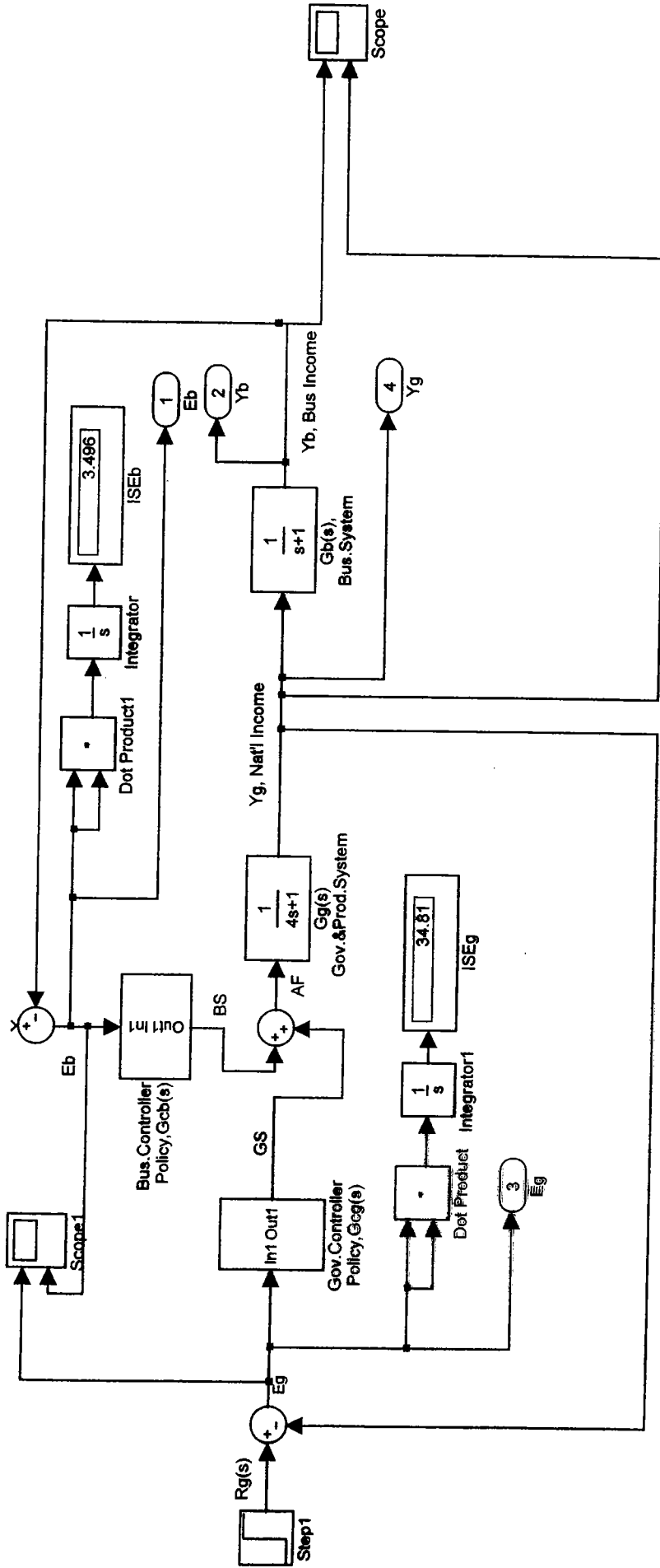

FIGURE 7 ZERO SIGNAL INJECTION FROM BUSINESS WITH SYSTEM MODIFICATION

AF=Available Funds

GS(s)=Gov't Spending

BS= Bus. Spending

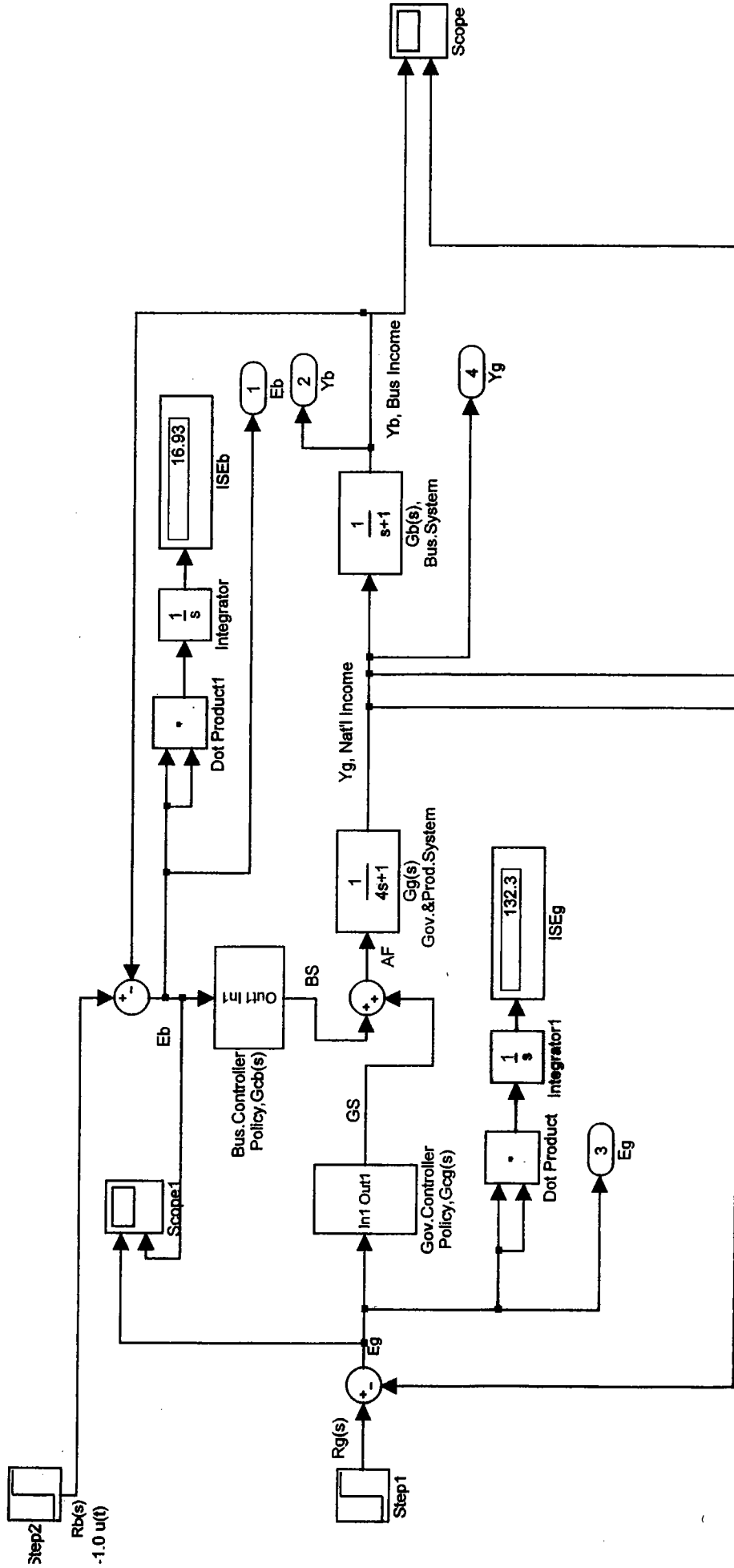
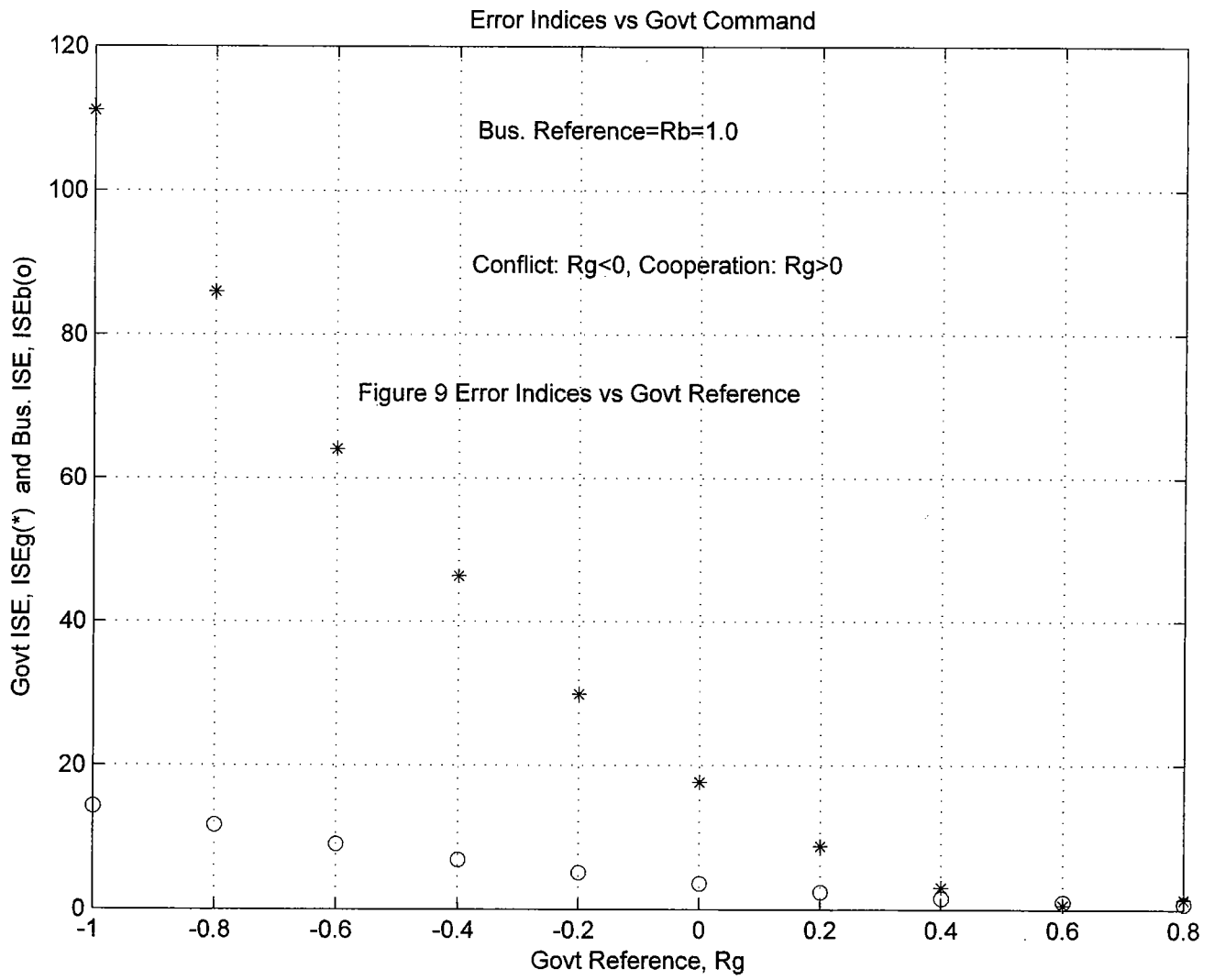

FIGURE 8 EXAMPLE OF CONFLICT THROUGH SIGNAL INJECTION

AF=Available Funds

GS(s)=Gov't
Spending

BS= Bus. Spending



Error Indices vs Business Command

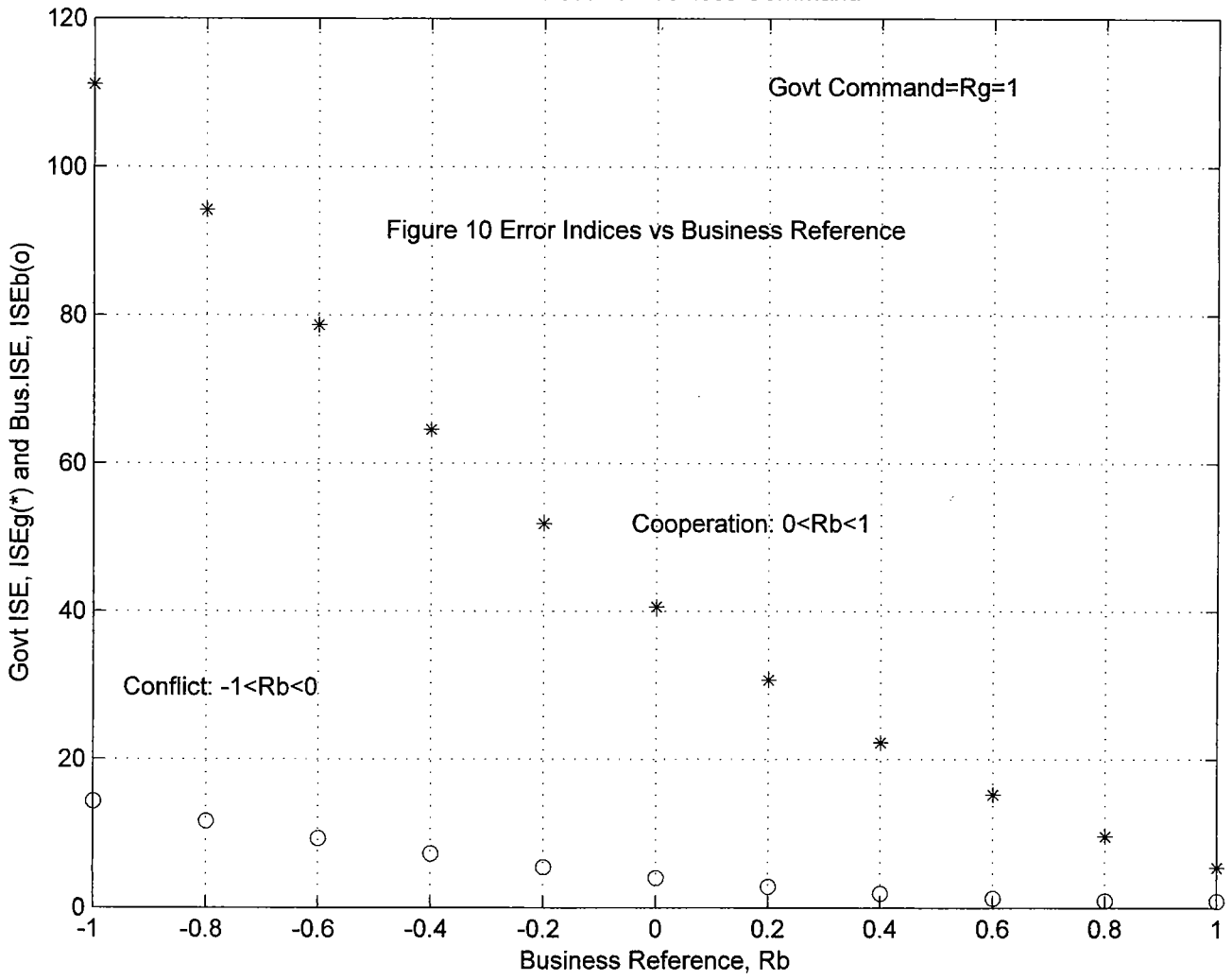

The National Economy as an Example of Control Under Conflict/Cooperation- A Simulation Approach

Robert L. Drake, Ph.D., P.E.
Department of Electrical and Computer Engineering
Christian Brothers University
Memphis, Tennessee
rdrake@cbu.edu

BACKGROUND

The work reported here is the result of teaching a course entitled ECE 488 Modeling and Simulation in Engineering Problems. This course is offered to students in both engineering and non-engineering. All students are required to simulate several dynamic systems during the semester at least one of which must be socio-political-economic (SPE) in nature. As instructor of the course, the writer chose the initial model of the national economy as an example of SPE systems to present to the class. This model was taken from reference [1] initially, and then as discussion progressed “refinements” were added. One of these refinements were reported in an earlier paper [2], where additional work suggested includes that of possible conflicts between the goals of government and the goals of business. The work reported here is the first attempt of the writer to approach that problem.

MODEL

The model hypothesized in this work is shown in the block diagram of Figure 1. Although inspired by the model suggested in reference [1], the model differs in several respects, among which are the inclusion of business investment as a separate input of the two-input system, identification of separate decision-making (controllers) for government and business, identification of different performance indices for government and business, and inclusion of two distinct outputs from the system. The inputs to the system are shown as business reference input (R_b) and the government reference input (R_g). The outputs from the system are shown as the national income level (Y_g) and the business income level (Y_b).

Figure 2 shows the identification of two performance indices chosen in this study. The performance index for government is based on the error, or difference, between the desired change in national income level and the measured change, E_g . In this case the integral squared value of this error is taken as the performance index. For business the error, or difference, is E_b as measured by the desired change in business income and the actual value. Again, the integral squared value of this error is used as the performance index.

Figure 3 shows the proportional plus integral (PI) controller chosen for the government controller. The controller constants were chosen to provide critical damping for the isolated government system. The government system is defined as isolated when the business input is set to zero (command for no change) and the business spending signal (BS) is set to zero. The simulation of the isolated government loop is shown in Figure 5 along with the indicated integral square error (ISE_g) of 6.681 for the unit step response which can be checked with theory for this particular index of performance. Figure 4 shows the PI controller chosen for the isolated business loop and Figure 6 shows the simulation result for this case where the ISE_b is 2.5 which also is checked by application of theory.

In Figure 1 the system representing government and production operations is shown with time constant of 4 time units and “dc” gain of 1. The system representing business operations is shown with time constant of 1 time unit and gain of 1.

DEFINITION OF CONFLICT AND COOPERATION

In Figure 2 the goal of government is to reduce as much as possible the performance index defined in this case as the integral square of the error signal E_g shown as ISE_g. The goal of business is to reduce ISE_b as much as possible. In the model shown, there is coupling between the government loop and the business loop with the result that propagation of signals in one loop affects the operation of the second loop. In the context of this work, conflict is defined to exist if the effect of the first loop upon the second loop is such that the performance index of the second is worsened, or increased in this case where the goal is to decrease the ISE. Similarly, cooperation is defined to exist if the coupling effect improves the performance index.

Simulation makes obvious that conflict and cooperation can exist because of signal injection or because of system modification without signal injection, or both. In Figure 7 no signal is injected by the business system, but because of the presence of the business feedback loop the government performance index ISE_g is increased by a factor of (34.81/6.68), or 5.2 to 1. By the definition above, conflict exists. On the other hand, in Figure 8 signal injection at the business reference input R_b along with the feedback in the business loop results in ISE_g increase by a factor of (132.3/6.68), or 19.8 to 1. Conflict from signal injection in this case results from the opposite signs in the reference input to the government loop and reference input to the business loop.

ADDITIONAL SIMULATION RESULTS

Additional simulation results are shown in Figures 9 and 10. Figure 9 shows the variation of the performance indices ISE_g and ISE_b with government reference R_g with business reference R_b held constant at unity. By the definitions above for cooperation and conflict,

cooperation increases as R_g varies from 0 to 1 and conflict increases as R_g varies from 0 to -1. There is a rapid increase in the error indices as the conflict increases and a rapid decrease in the error indices as the cooperation increases. Figure 10 shows the variation of the error indices as a function of the business reference R_b with the government reference held constant at unity. Again, there is a rapid increase in error indices as conflict increases and a rapid decrease in error indices as cooperation increases.

SUMMARY AND CONCLUSIONS

(1) Conflict may be defined by the actions of one participant, say business, tending to increase the performance index being minimized by the second participant, say government. Cooperation may be defined as existing when the actions of one of the participants tends to reduce the performance index being minimized by the second participant.

(2) Cooperation/conflict may result from either signal injection or from system modification, or both.

FUTURE WORK

(1) The effects of consumers should be added to the model. With three participants present, the possibility of joint cooperation/conflict arises. Include the effect of foreign investment.

(2) Practical data and reasonable scaling limits should be added. This probably requires participation of personnel with backgrounds in business and economics.

(3) Re-phrase the problem in terms of state variables and vector-matrix operations. Use modern control theory to re-design the controllers. Consider the possibility of decoupling output except from one input.

FINAL COMMENTS

(1) This is a work in progress.

(2) Results and conclusions, although believed to be original, are preliminary and should be considered as such.

REFERENCES

- [1] S.M. Shinnars, Modern Control Theory and Application, Reading, MA, Addison-Wesley, 1972.
- [2] R.L. Drake, "Do Checks and Balances Contribute to Cycles in the Economy?", MAESC 2003, Christian Brothers University, Memphis, TN, May 15, 2003.

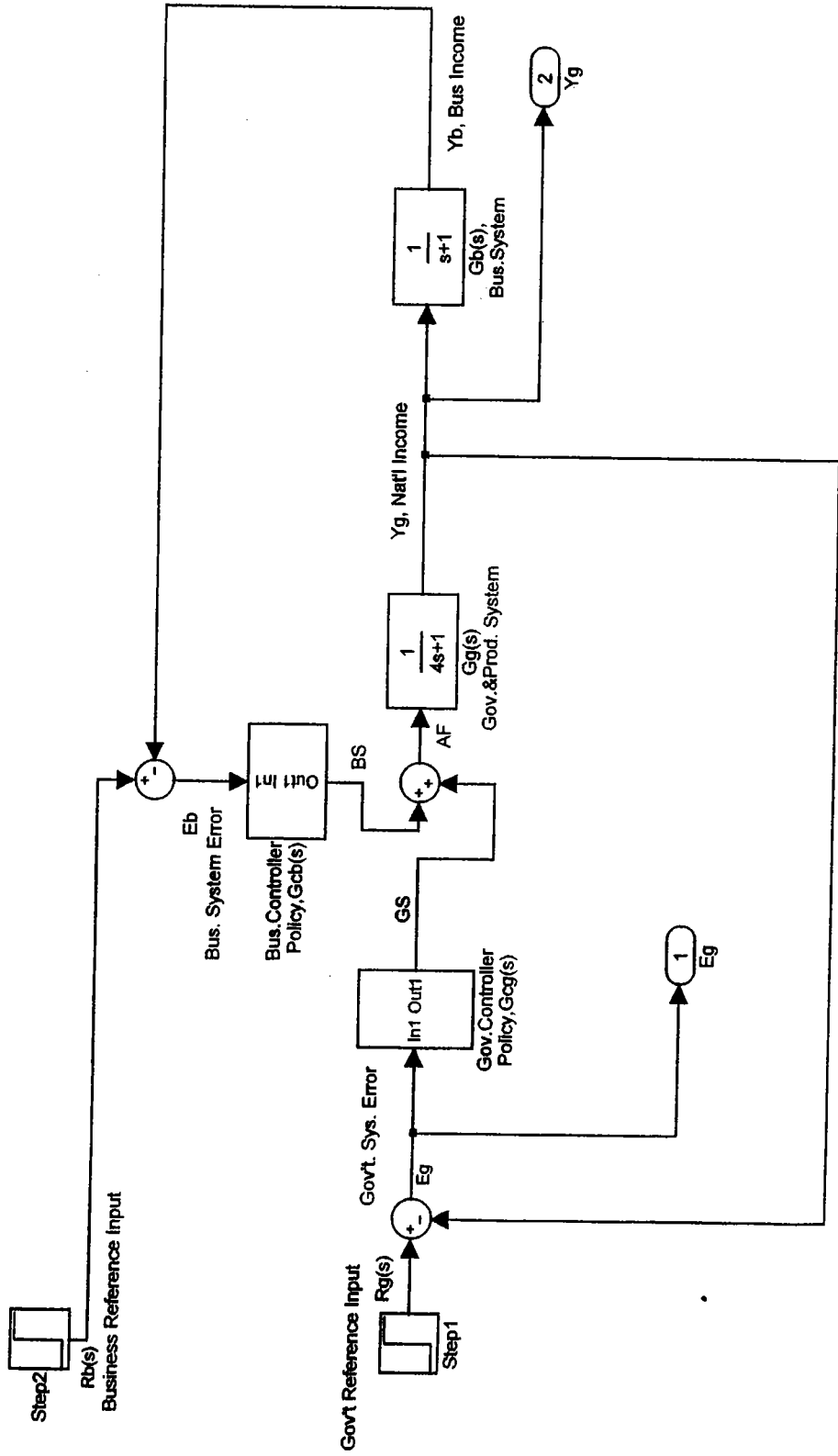

FIGURE 1 BLOCK DIAGRAM

AF=Available Funds

$G_S(s)$ =Gov't Spending

BS= Bus. Spending

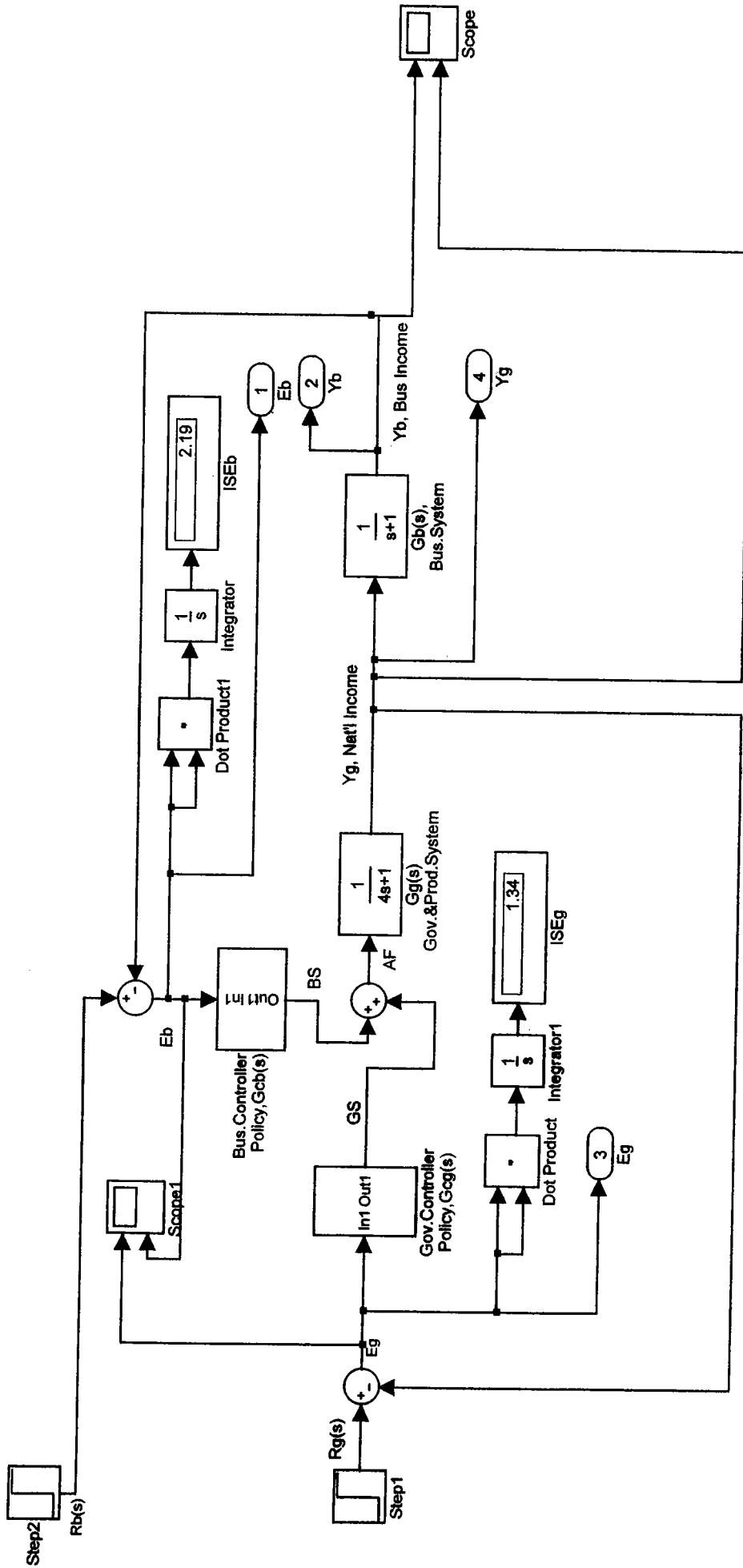

FIGURE 2 BLOCK DIAGRAM with VIRTUAL INSTRUMENTATION and COMPUTATION

AF=Available Funds
 GS(s)=Gov't Spending
 BS= Bus. Spending

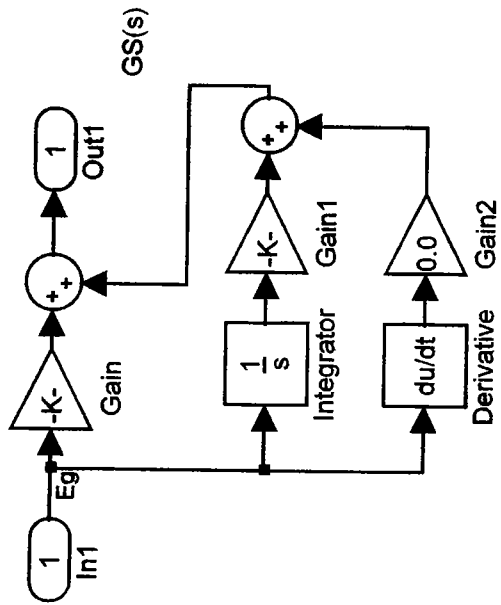

FIGURE 3 GOVERNMENT PI CONTROLLER

$Kp=0.1716$

$Ki=0.0858$

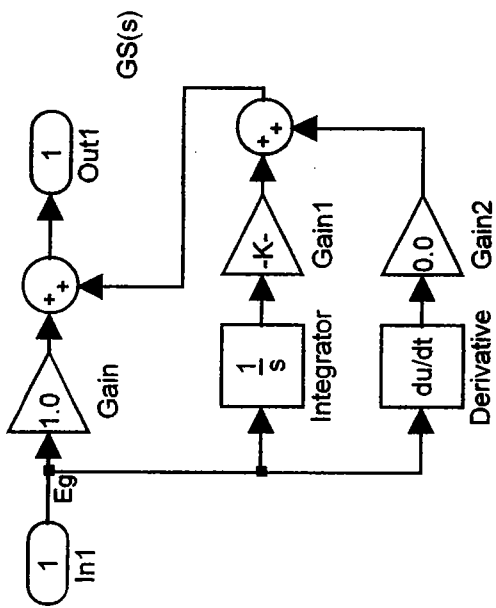

FIGURE 4 BUSINESS PI CONTROLLER

$K_p=1.0$
 $K_i=0.25$

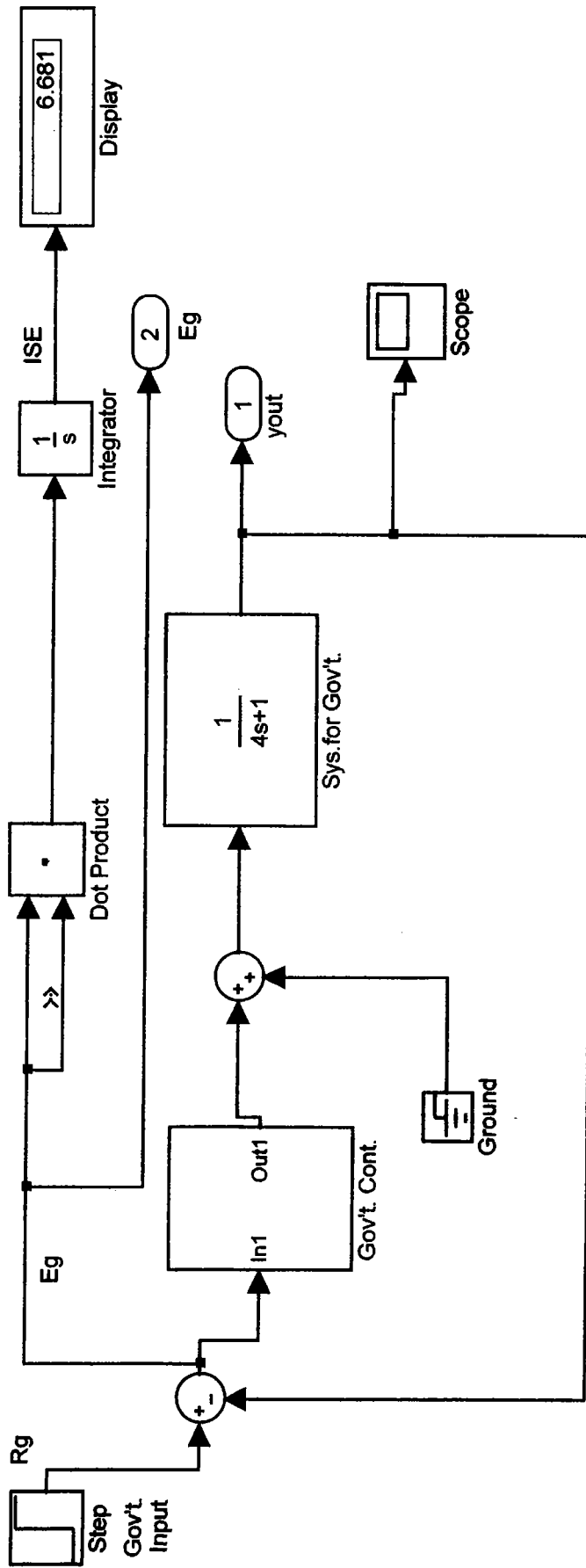

FIGURE 5 ISOLATED GOVERNMENT LOOP

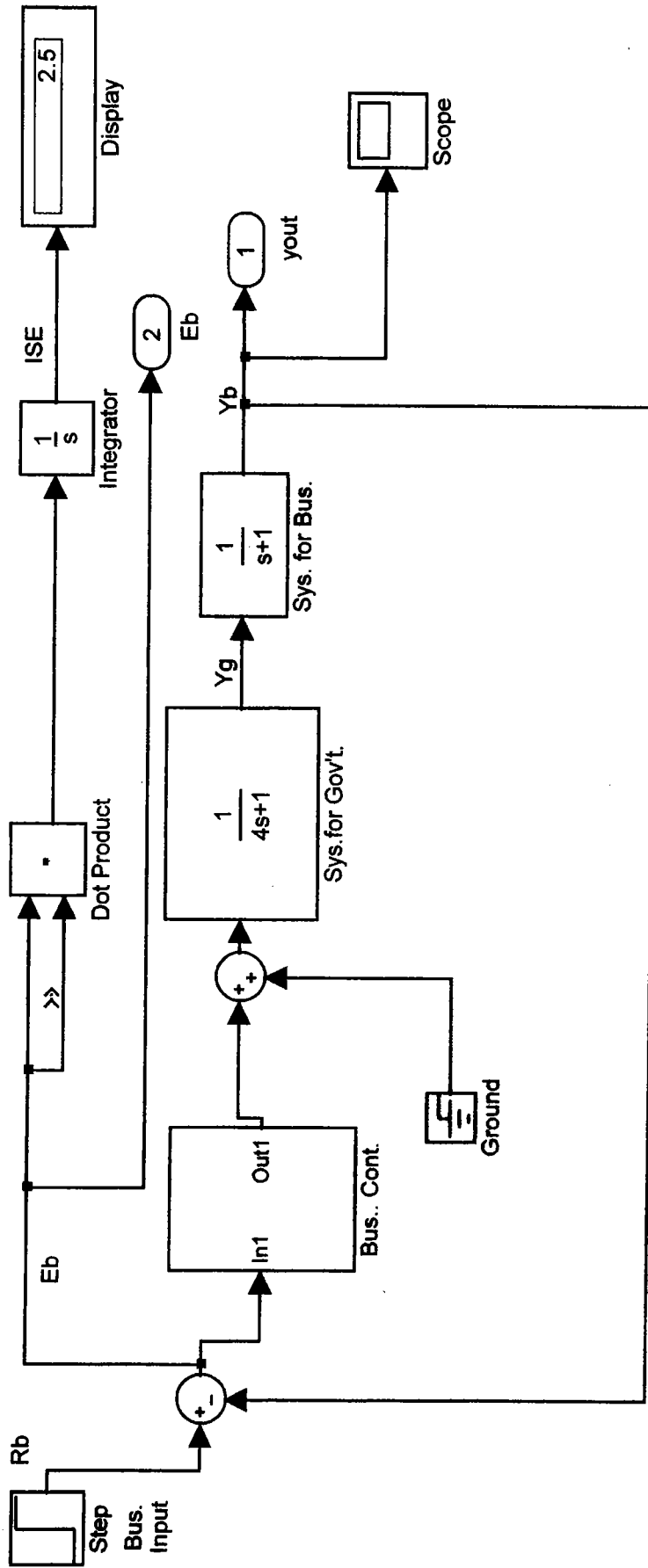

FIGURE 6 ISOLATED BUSINESS LOOP

Step2

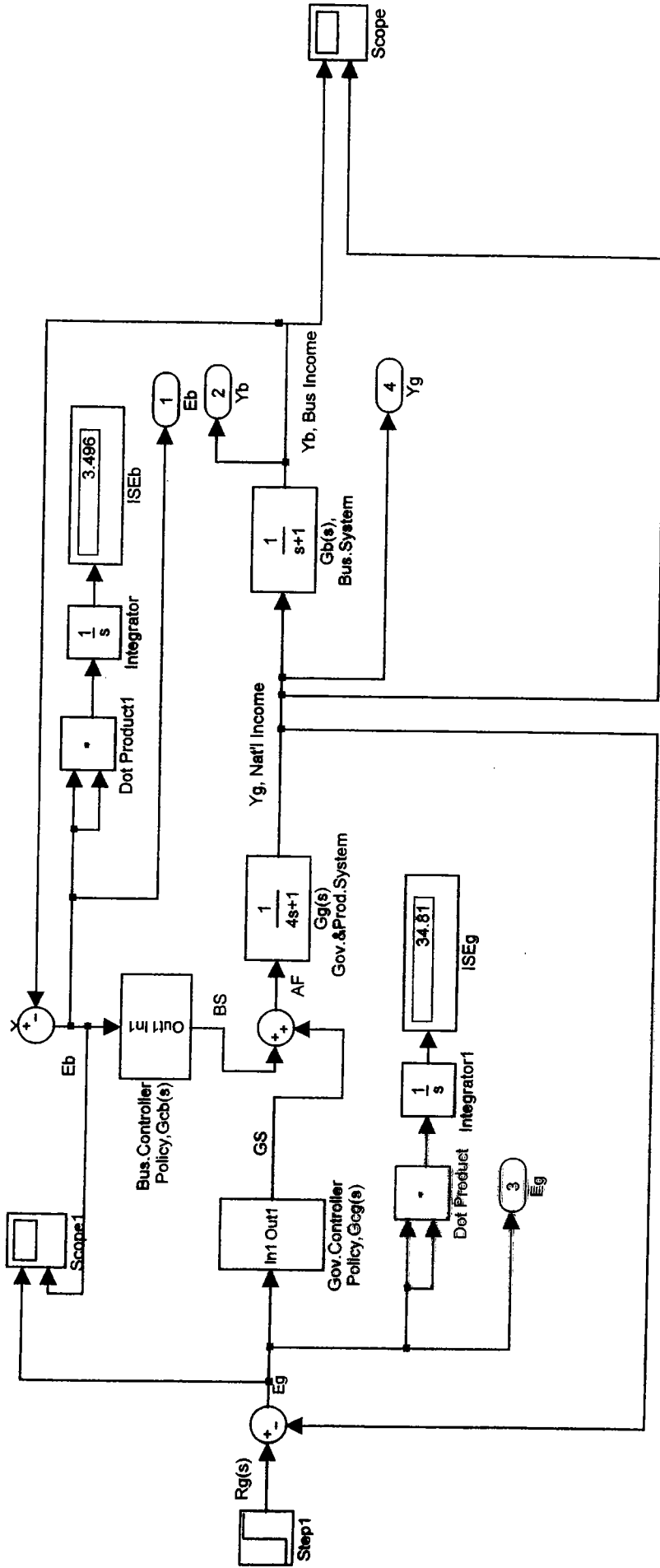

FIGURE 7 ZERO SIGNAL INJECTION FROM BUSINESS WITH SYSTEM MODIFICATION

AF=Available Funds

GS(s)=Gov't Spending

BS= Bus. Spending

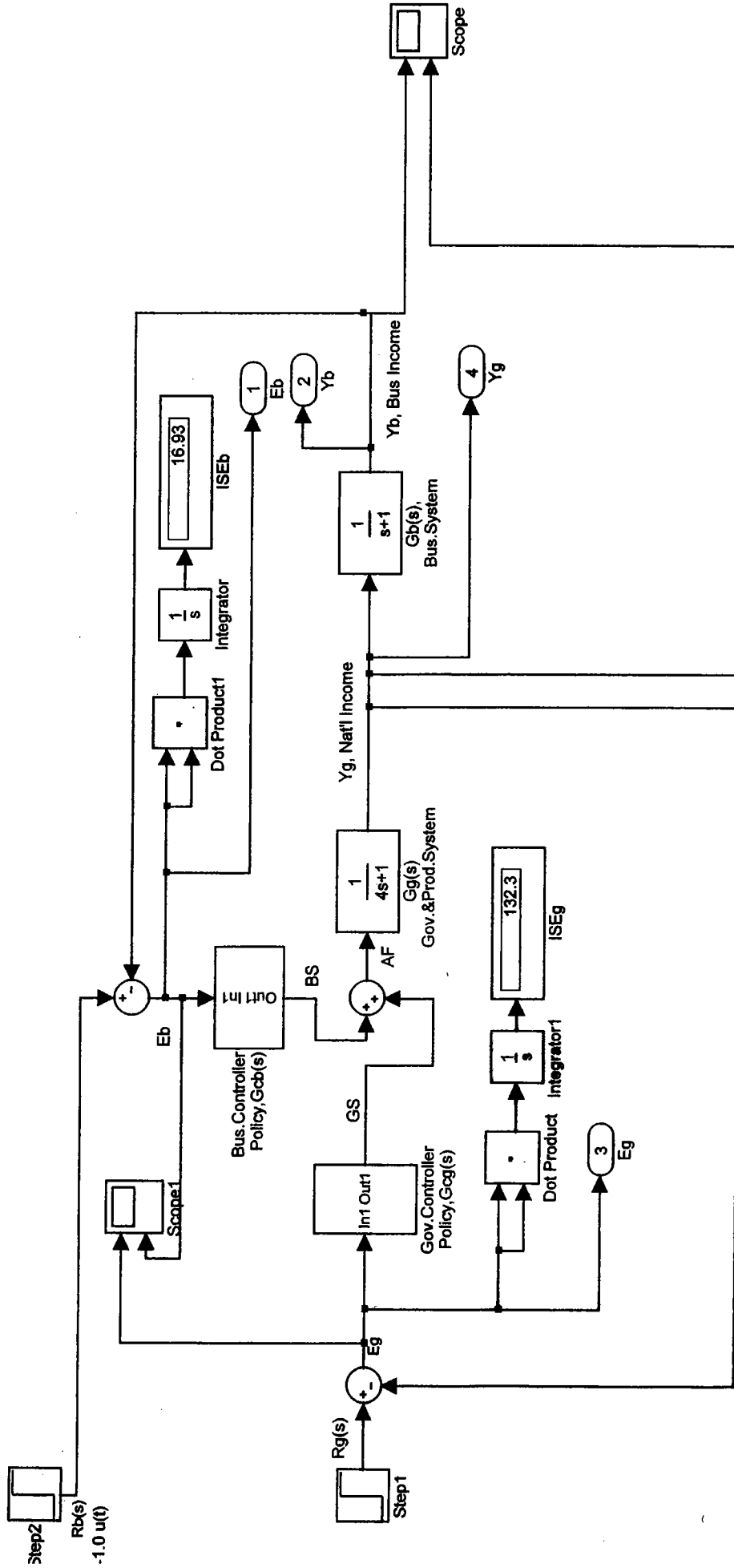
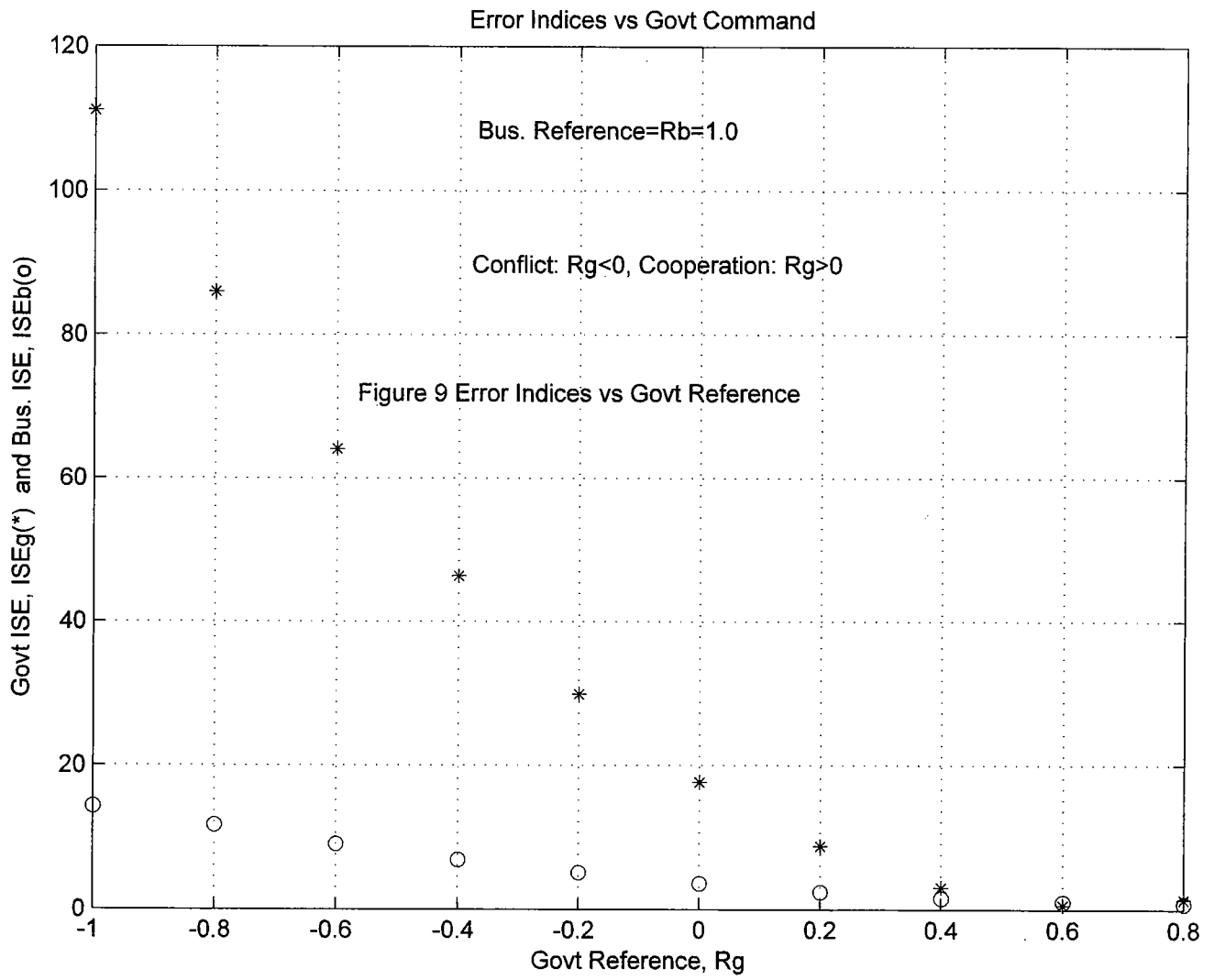

FIGURE 8 EXAMPLE OF CONFLICT THROUGH SIGNAL INJECTION

AF=Available Funds

GS(s)=Gov't
Spending

BS= Bus. Spending



Error Indices vs Business Command

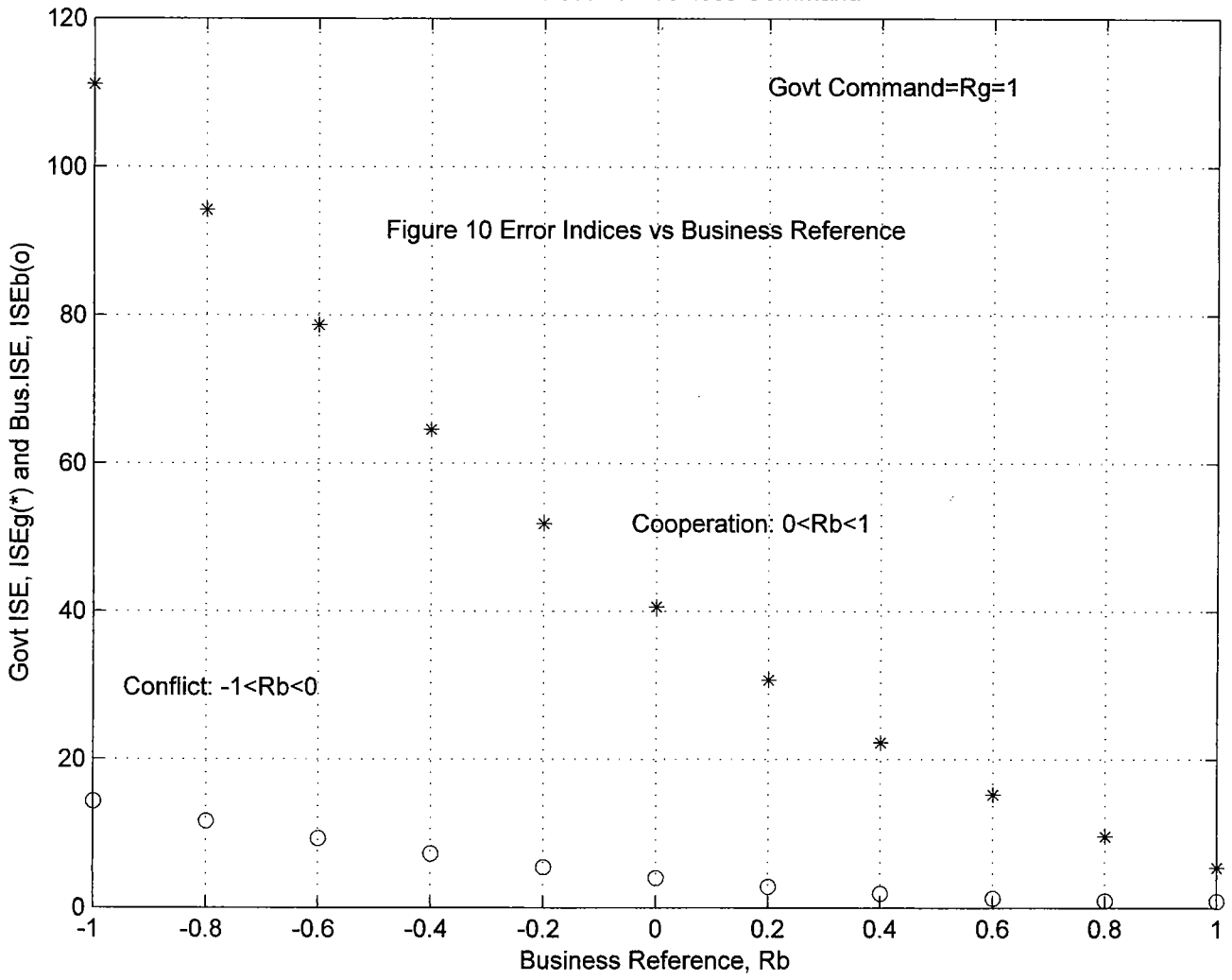

The National Economy as an Example of Control Under Conflict/Cooperation- A Simulation Approach

Robert L. Drake, Ph.D., P.E.
Department of Electrical and Computer Engineering
Christian Brothers University
Memphis, Tennessee
rdrake@cbu.edu

BACKGROUND

The work reported here is the result of teaching a course entitled ECE 488 Modeling and Simulation in Engineering Problems. This course is offered to students in both engineering and non-engineering. All students are required to simulate several dynamic systems during the semester at least one of which must be socio-political-economic (SPE) in nature. As instructor of the course, the writer chose the initial model of the national economy as an example of SPE systems to present to the class. This model was taken from reference [1] initially, and then as discussion progressed “refinements” were added. One of these refinements were reported in an earlier paper [2], where additional work suggested includes that of possible conflicts between the goals of government and the goals of business. The work reported here is the first attempt of the writer to approach that problem.

MODEL

The model hypothesized in this work is shown in the block diagram of Figure 1. Although inspired by the model suggested in reference [1], the model differs in several respects, among which are the inclusion of business investment as a separate input of the two-input system, identification of separate decision-making (controllers) for government and business, identification of different performance indices for government and business, and inclusion of two distinct outputs from the system. The inputs to the system are shown as business reference input (R_b) and the government reference input (R_g). The outputs from the system are shown as the national income level (Y_g) and the business income level (Y_b).

Figure 2 shows the identification of two performance indices chosen in this study. The performance index for government is based on the error, or difference, between the desired change in national income level and the measured change, E_g . In this case the integral squared value of this error is taken as the performance index. For business the error, or difference, is E_b as measured by the desired change in business income and the actual value. Again, the integral squared value of this error is used as the performance index.

Figure 3 shows the proportional plus integral (PI) controller chosen for the government controller. The controller constants were chosen to provide critical damping for the isolated government system. The government system is defined as isolated when the business input is set to zero (command for no change) and the business spending signal (BS) is set to zero. The simulation of the isolated government loop is shown in Figure 5 along with the indicated integral square error (ISE_g) of 6.681 for the unit step response which can be checked with theory for this particular index of performance. Figure 4 shows the PI controller chosen for the isolated business loop and Figure 6 shows the simulation result for this case where the ISE_b is 2.5 which also is checked by application of theory.

In Figure 1 the system representing government and production operations is shown with time constant of 4 time units and “dc” gain of 1. The system representing business operations is shown with time constant of 1 time unit and gain of 1.

DEFINITION OF CONFLICT AND COOPERATION

In Figure 2 the goal of government is to reduce as much as possible the performance index defined in this case as the integral square of the error signal E_g shown as ISE_g. The goal of business is to reduce ISE_b as much as possible. In the model shown, there is coupling between the government loop and the business loop with the result that propagation of signals in one loop affects the operation of the second loop. In the context of this work, conflict is defined to exist if the effect of the first loop upon the second loop is such that the performance index of the second is worsened, or increased in this case where the goal is to decrease the ISE. Similarly, cooperation is defined to exist if the coupling effect improves the performance index.

Simulation makes obvious that conflict and cooperation can exist because of signal injection or because of system modification without signal injection, or both. In Figure 7 no signal is injected by the business system, but because of the presence of the business feedback loop the government performance index ISE_g is increased by a factor of (34.81/6.68), or 5.2 to 1. By the definition above, conflict exists. On the other hand, in Figure 8 signal injection at the business reference input R_b along with the feedback in the business loop results in ISE_g increase by a factor of (132.3/6.68), or 19.8 to 1. Conflict from signal injection in this case results from the opposite signs in the reference input to the government loop and reference input to the business loop.

ADDITIONAL SIMULATION RESULTS

Additional simulation results are shown in Figures 9 and 10. Figure 9 shows the variation of the performance indices ISE_g and ISE_b with government reference R_g with business reference R_b held constant at unity. By the definitions above for cooperation and conflict,

cooperation increases as R_g varies from 0 to 1 and conflict increases as R_g varies from 0 to -1. There is a rapid increase in the error indices as the conflict increases and a rapid decrease in the error indices as the cooperation increases. Figure 10 shows the variation of the error indices as a function of the business reference R_b with the government reference held constant at unity. Again, there is a rapid increase in error indices as conflict increases and a rapid decrease in error indices as cooperation increases.

SUMMARY AND CONCLUSIONS

(1) Conflict may be defined by the actions of one participant, say business, tending to increase the performance index being minimized by the second participant, say government. Cooperation may be defined as existing when the actions of one of the participants tends to reduce the performance index being minimized by the second participant.

(2) Cooperation/conflict may result from either signal injection or from system modification, or both.

FUTURE WORK

(1) The effects of consumers should be added to the model. With three participants present, the possibility of joint cooperation/conflict arises. Include the effect of foreign investment.

(2) Practical data and reasonable scaling limits should be added. This probably requires participation of personnel with backgrounds in business and economics.

(3) Re-phrase the problem in terms of state variables and vector-matrix operations. Use modern control theory to re-design the controllers. Consider the possibility of decoupling output except from one input.

FINAL COMMENTS

(1) This is a work in progress.

(2) Results and conclusions, although believed to be original, are preliminary and should be considered as such.

REFERENCES

- [1] S.M. Shinnars, Modern Control Theory and Application, Reading, MA, Addison-Wesley, 1972.
- [2] R.L. Drake, "Do Checks and Balances Contribute to Cycles in the Economy?", MAESC 2003, Christian Brothers University, Memphis, TN, May 15, 2003.

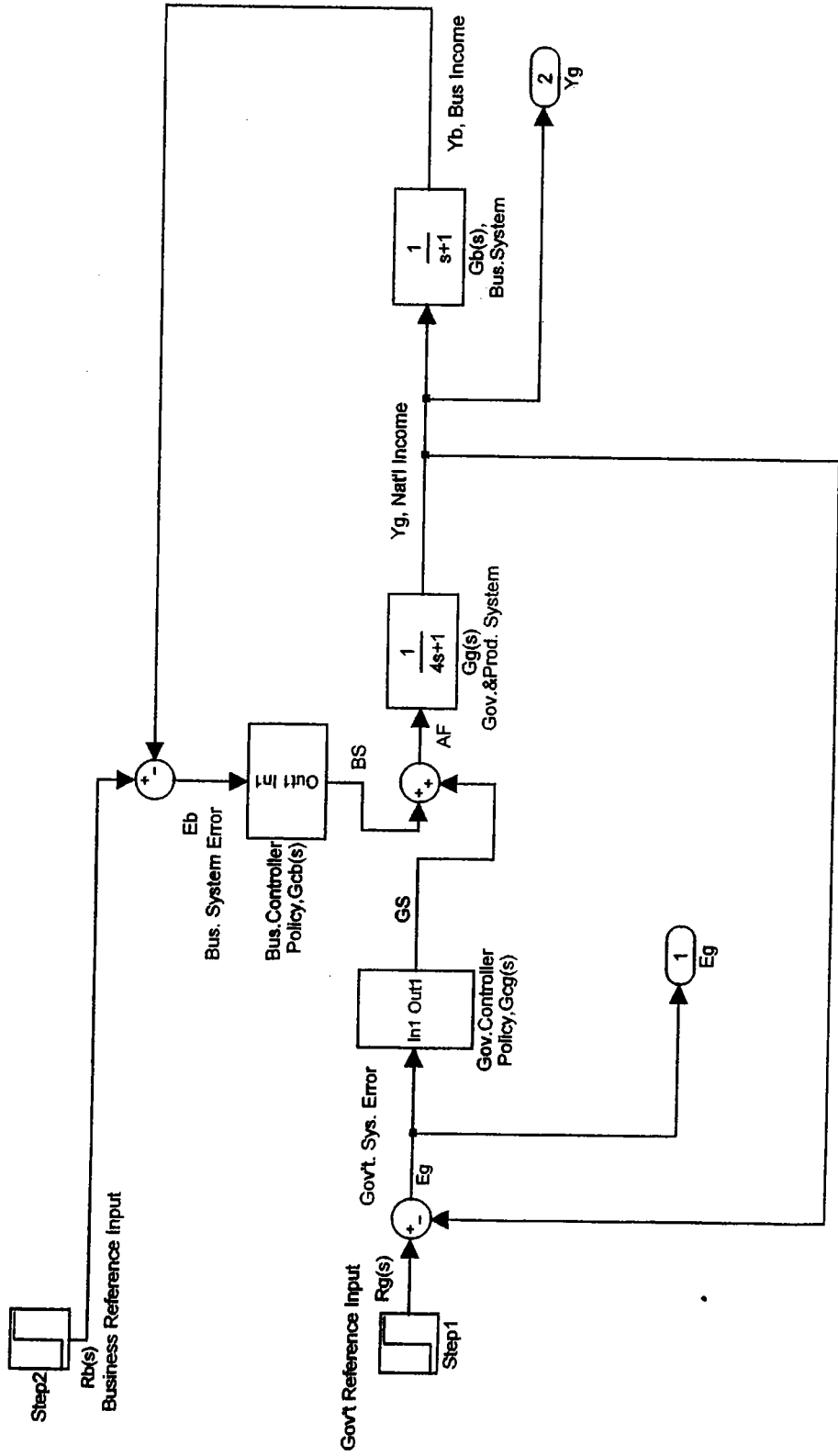

FIGURE 1 BLOCK DIAGRAM

AF=Available Funds
 GS(s)=Gov't Spending
 BS= Bus. Spending

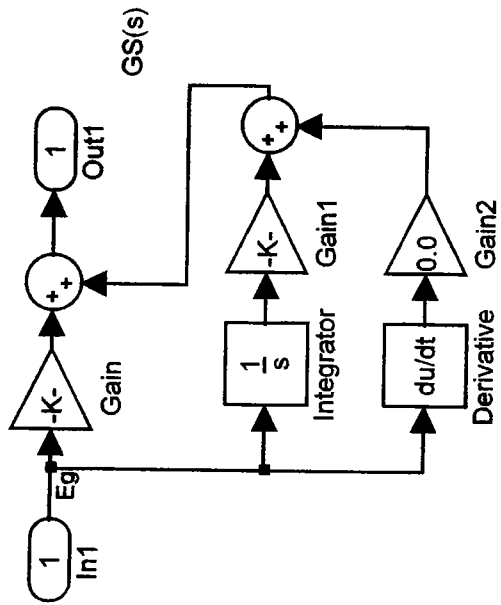

FIGURE 3 GOVERNMENT PI CONTROLLER

$K_p=0.1716$

$K_i=0.0858$

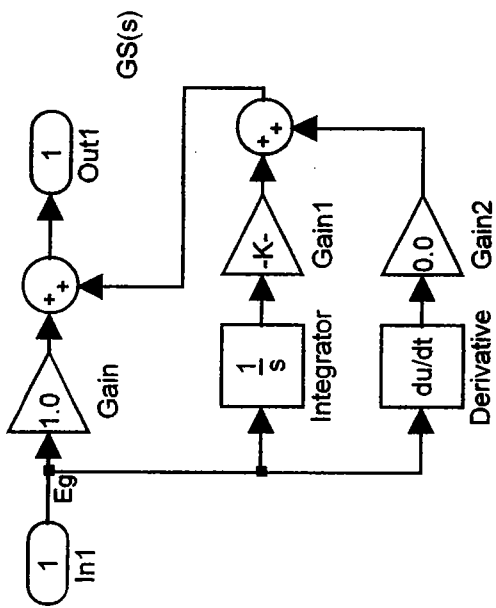

FIGURE 4 BUSINESS PI CONTROLLER

$Kp=1.0$
 $Ki=0.25$

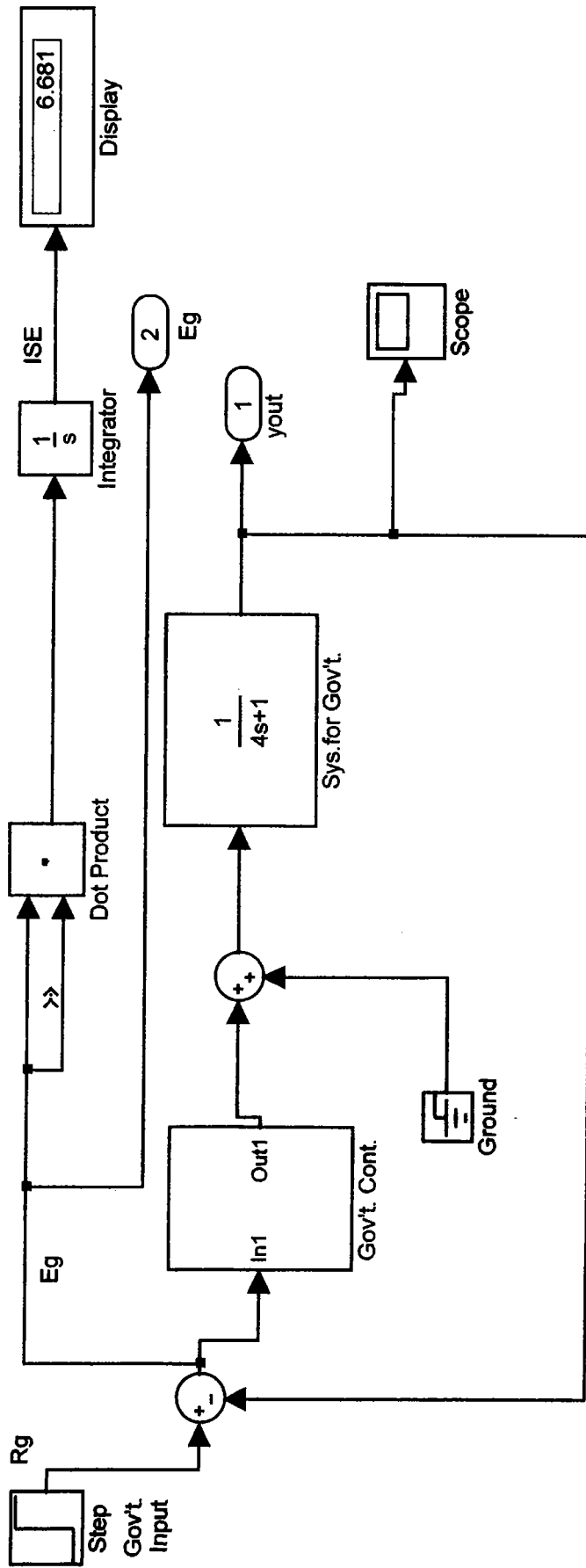

FIGURE 5 ISOLATED GOVERNMENT LOOP

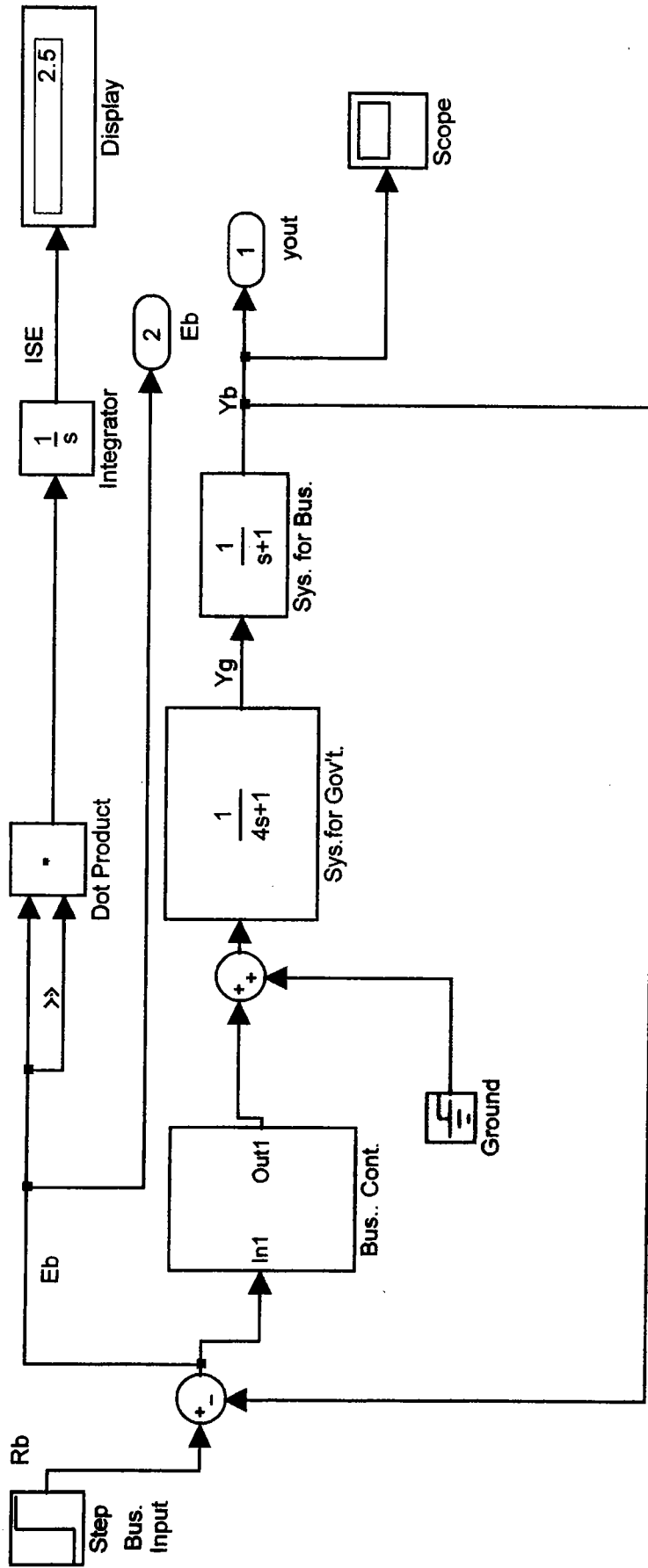

FIGURE 6 ISOLATED BUSINESS LOOP

Step2

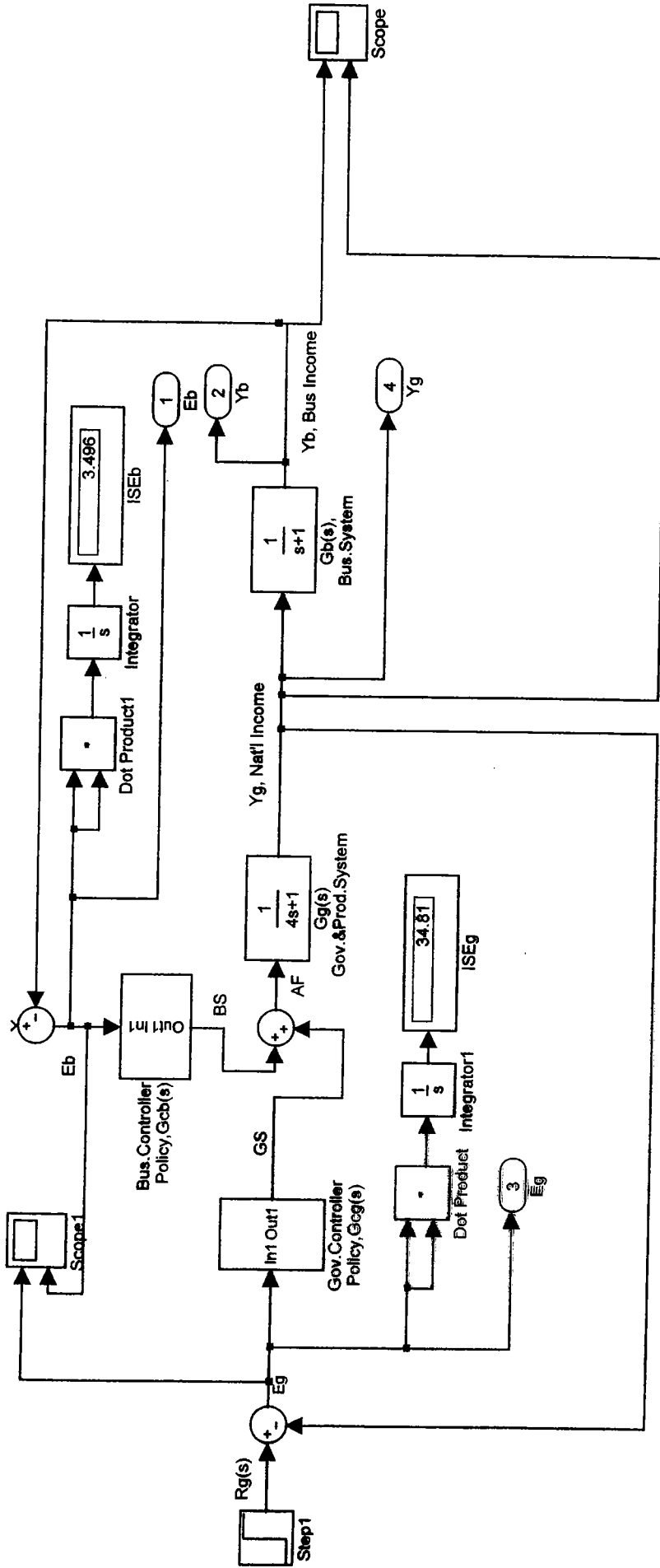

FIGURE 7 ZERO SIGNAL INJECTION FROM BUSINESS WITH SYSTEM MODIFICATION

AF=Available Funds

GS(s)=Gov't Spending

BS= Bus. Spending

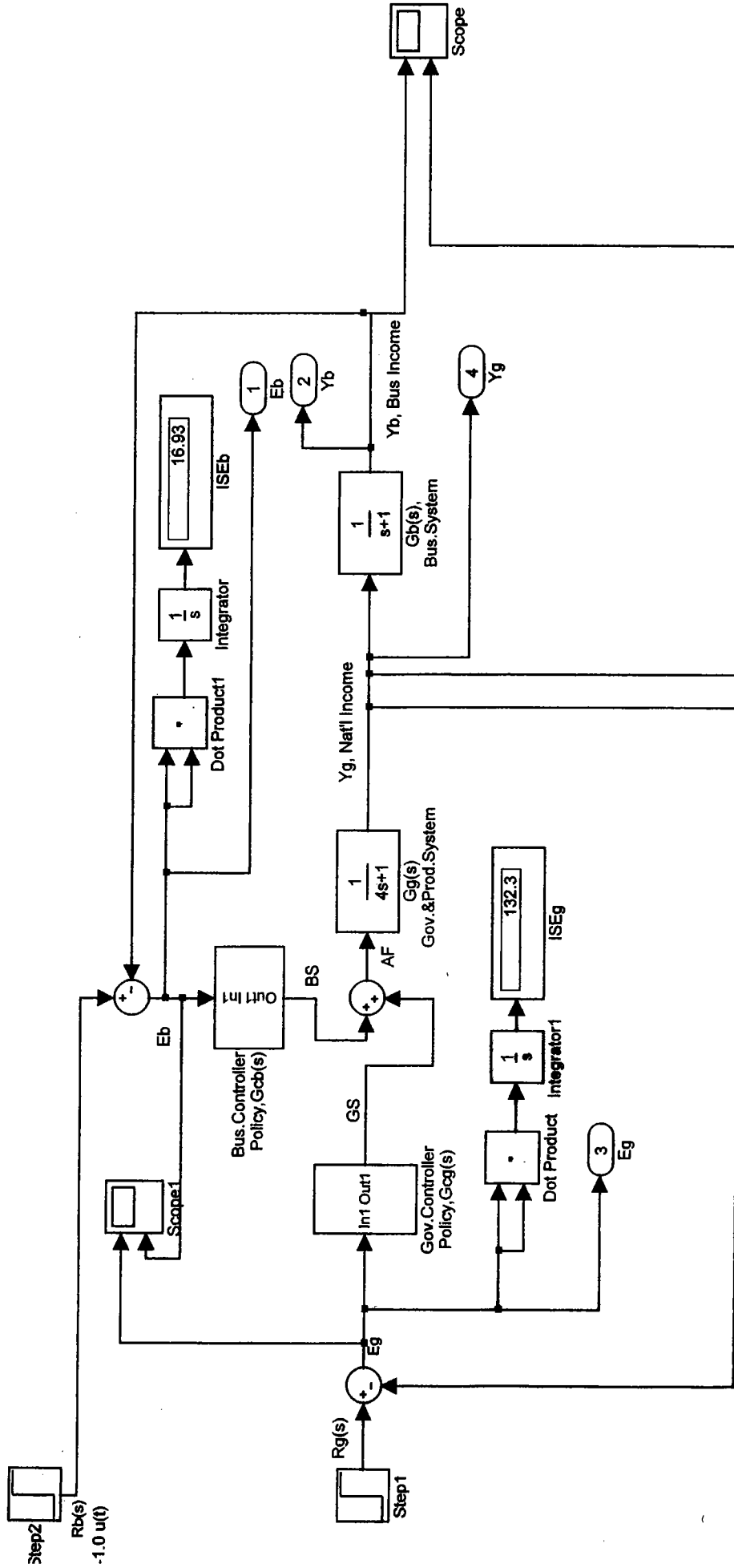
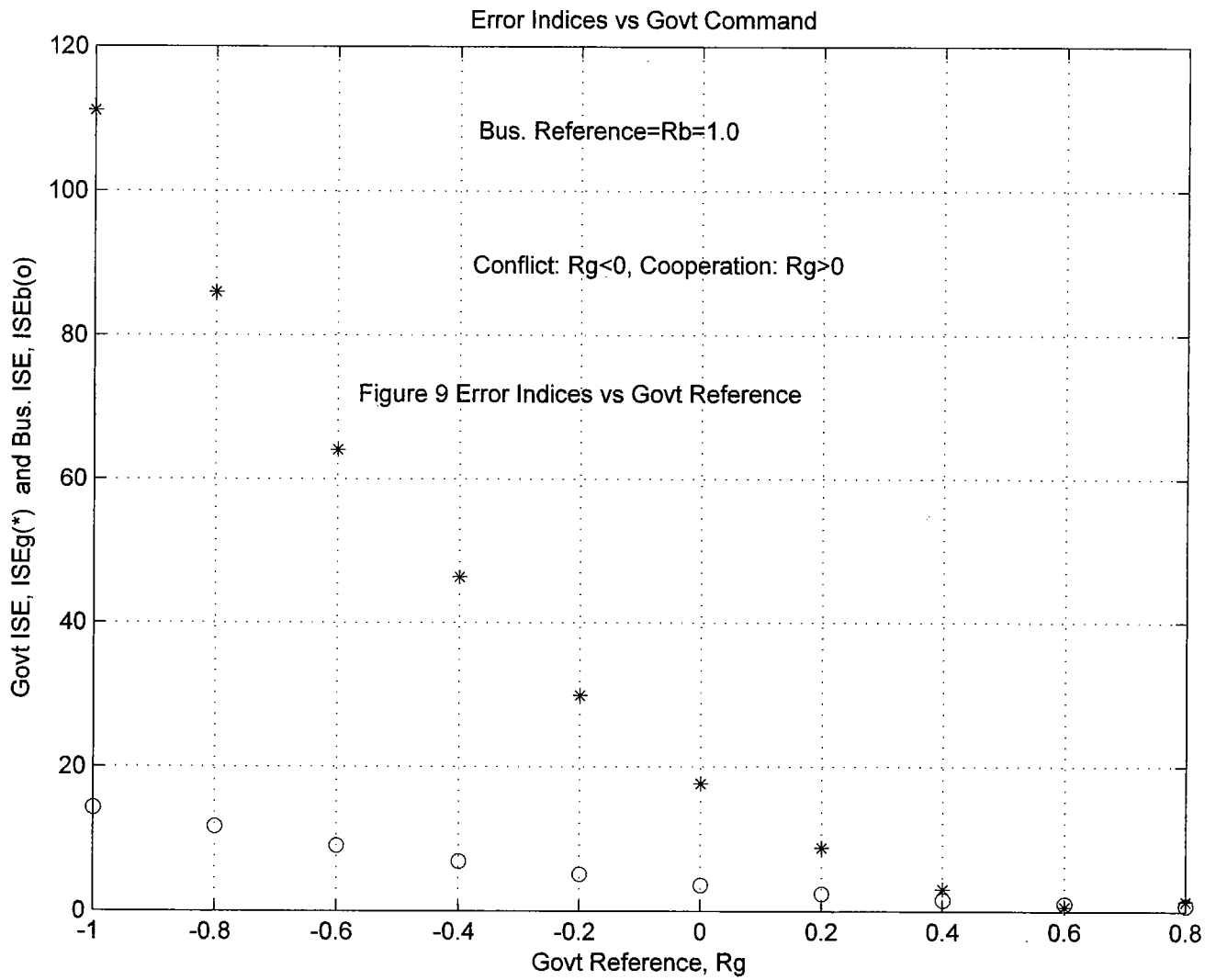

FIGURE 8 EXAMPLE OF CONFLICT THROUGH SIGNAL INJECTION

AF=Available Funds

GS(s)=Gov't Spending

BS= Bus. Spending



Error Indices vs Business Command

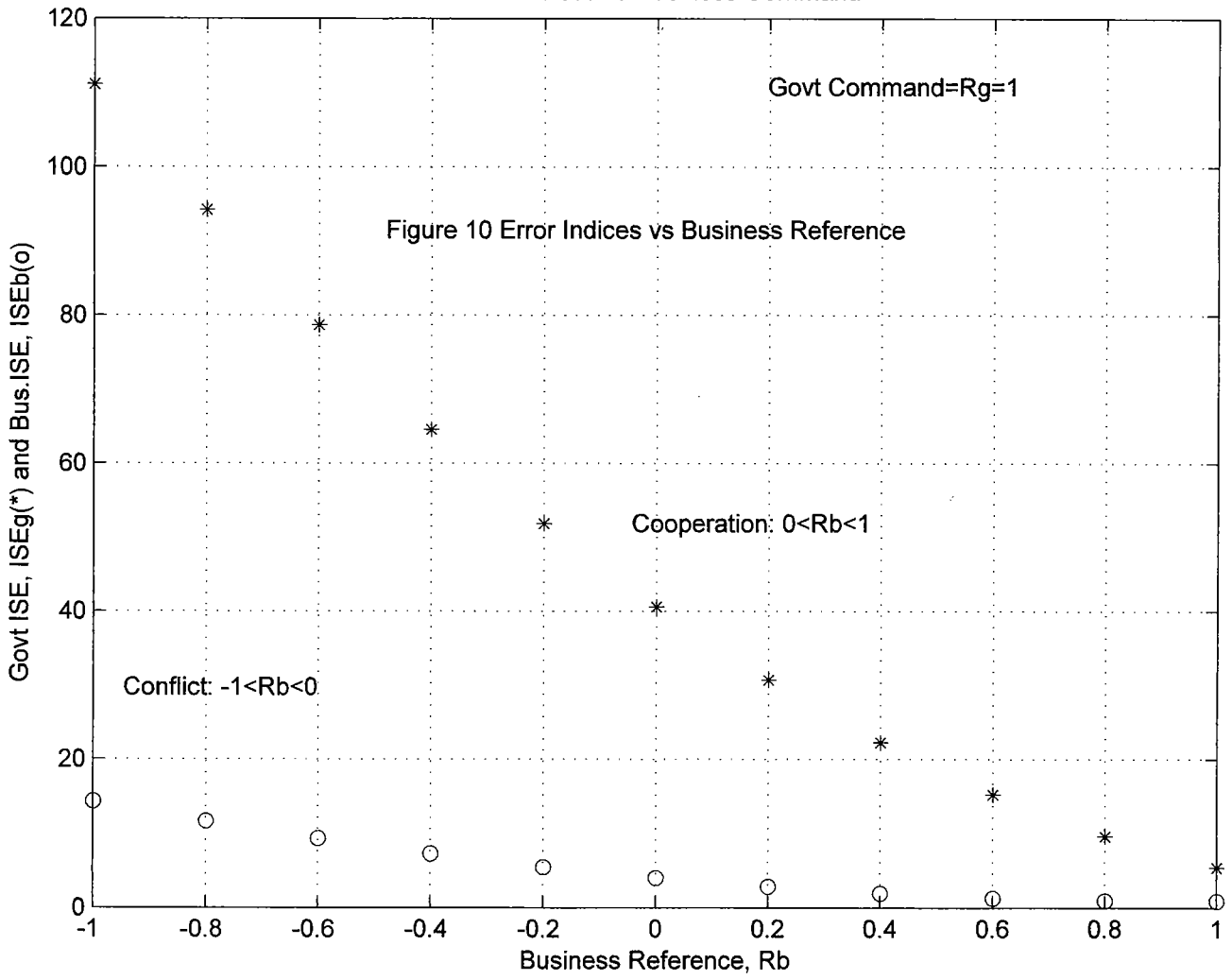

The National Economy as an Example of Control Under Conflict/Cooperation- A Simulation Approach

Robert L. Drake, Ph.D., P.E.
Department of Electrical and Computer Engineering
Christian Brothers University
Memphis, Tennessee
rdrake@cbu.edu

BACKGROUND

The work reported here is the result of teaching a course entitled ECE 488 Modeling and Simulation in Engineering Problems. This course is offered to students in both engineering and non-engineering. All students are required to simulate several dynamic systems during the semester at least one of which must be socio-political-economic (SPE) in nature. As instructor of the course, the writer chose the initial model of the national economy as an example of SPE systems to present to the class. This model was taken from reference [1] initially, and then as discussion progressed “refinements” were added. One of these refinements were reported in an earlier paper [2], where additional work suggested includes that of possible conflicts between the goals of government and the goals of business. The work reported here is the first attempt of the writer to approach that problem.

MODEL

The model hypothesized in this work is shown in the block diagram of Figure 1. Although inspired by the model suggested in reference [1], the model differs in several respects, among which are the inclusion of business investment as a separate input of the two-input system, identification of separate decision-making (controllers) for government and business, identification of different performance indices for government and business, and inclusion of two distinct outputs from the system. The inputs to the system are shown as business reference input (R_b) and the government reference input (R_g). The outputs from the system are shown as the national income level (Y_g) and the business income level (Y_b).

Figure 2 shows the identification of two performance indices chosen in this study. The performance index for government is based on the error, or difference, between the desired change in national income level and the measured change, E_g . In this case the integral squared value of this error is taken as the performance index. For business the error, or difference, is E_b as measured by the desired change in business income and the actual value. Again, the integral squared value of this error is used as the performance index.

Figure 3 shows the proportional plus integral (PI) controller chosen for the government controller. The controller constants were chosen to provide critical damping for the isolated government system. The government system is defined as isolated when the business input is set to zero (command for no change) and the business spending signal (BS) is set to zero. The simulation of the isolated government loop is shown in Figure 5 along with the indicated integral square error (ISE_g) of 6.681 for the unit step response which can be checked with theory for this particular index of performance. Figure 4 shows the PI controller chosen for the isolated business loop and Figure 6 shows the simulation result for this case where the ISE_b is 2.5 which also is checked by application of theory.

In Figure 1 the system representing government and production operations is shown with time constant of 4 time units and “dc” gain of 1. The system representing business operations is shown with time constant of 1 time unit and gain of 1.

DEFINITION OF CONFLICT AND COOPERATION

In Figure 2 the goal of government is to reduce as much as possible the performance index defined in this case as the integral square of the error signal E_g shown as ISE_g. The goal of business is to reduce ISE_b as much as possible. In the model shown, there is coupling between the government loop and the business loop with the result that propagation of signals in one loop affects the operation of the second loop. In the context of this work, conflict is defined to exist if the effect of the first loop upon the second loop is such that the performance index of the second is worsened, or increased in this case where the goal is to decrease the ISE. Similarly, cooperation is defined to exist if the coupling effect improves the performance index.

Simulation makes obvious that conflict and cooperation can exist because of signal injection or because of system modification without signal injection, or both. In Figure 7 no signal is injected by the business system, but because of the presence of the business feedback loop the government performance index ISE_g is increased by a factor of (34.81/6.68), or 5.2 to 1. By the definition above, conflict exists. On the other hand, in Figure 8 signal injection at the business reference input R_b along with the feedback in the business loop results in ISE_g increase by a factor of (132.3/6.68), or 19.8 to 1. Conflict from signal injection in this case results from the opposite signs in the reference input to the government loop and reference input to the business loop.

ADDITIONAL SIMULATION RESULTS

Additional simulation results are shown in Figures 9 and 10. Figure 9 shows the variation of the performance indices ISE_g and ISE_b with government reference R_g with business reference R_b held constant at unity. By the definitions above for cooperation and conflict,

cooperation increases as R_g varies from 0 to 1 and conflict increases as R_g varies from 0 to -1. There is a rapid increase in the error indices as the conflict increases and a rapid decrease in the error indices as the cooperation increases. Figure 10 shows the variation of the error indices as a function of the business reference R_b with the government reference held constant at unity. Again, there is a rapid increase in error indices as conflict increases and a rapid decrease in error indices as cooperation increases.

SUMMARY AND CONCLUSIONS

- (1) Conflict may be defined by the actions of one participant, say business, tending to increase the performance index being minimized by the second participant, say government. Cooperation may be defined as existing when the actions of one of the participants tends to reduce the performance index being minimized by the second participant.
- (2) Cooperation/conflict may result from either signal injection or from system modification, or both.

FUTURE WORK

- (1) The effects of consumers should be added to the model. With three participants present, the possibility of joint cooperation/conflict arises. Include the effect of foreign investment.
- (2) Practical data and reasonable scaling limits should be added. This probably requires participation of personnel with backgrounds in business and economics.
- (3) Re-phrase the problem in terms of state variables and vector-matrix operations. Use modern control theory to re-design the controllers. Consider the possibility of decoupling output except from one input.

FINAL COMMENTS

- (1) This is a work in progress.
- (2) Results and conclusions, although believed to be original, are preliminary and should be considered as such.

REFERENCES

- [1] S.M. Shinnars, Modern Control Theory and Application, Reading, MA, Addison-Wesley, 1972.
- [2] R.L. Drake, "Do Checks and Balances Contribute to Cycles in the Economy?", MAESC 2003, Christian Brothers University, Memphis, TN, May 15, 2003.

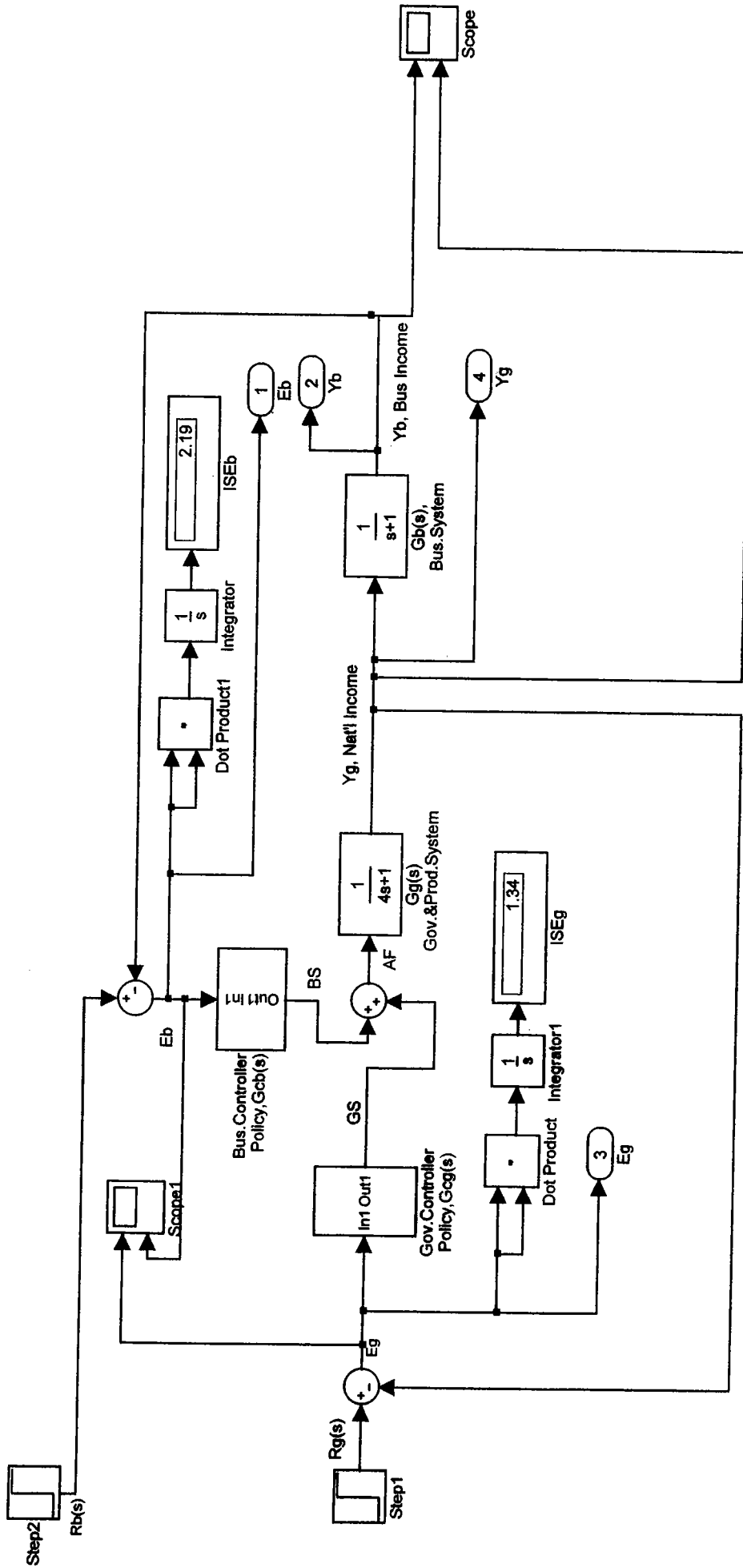

FIGURE 2 BLOCK DIAGRAM with VIRTUAL INSTRUMENTATION and COMPUTATION

AF=Available Funds
 GS(s)=Gov't Spending
 BS= Bus. Spending

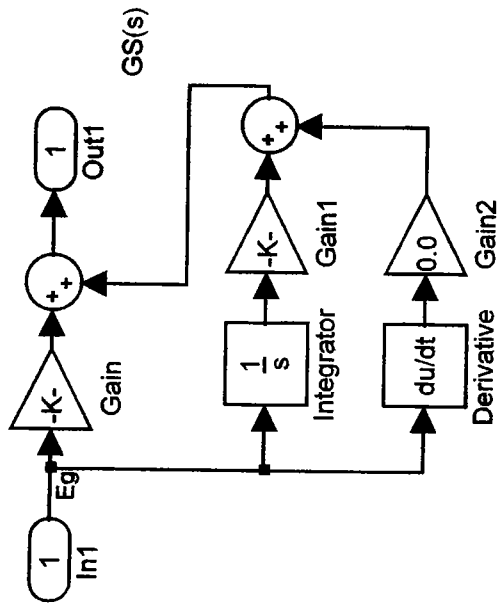

FIGURE 3 GOVERNMENT PI CONTROLLER

$K_p=0.1716$

$K_i=0.0858$

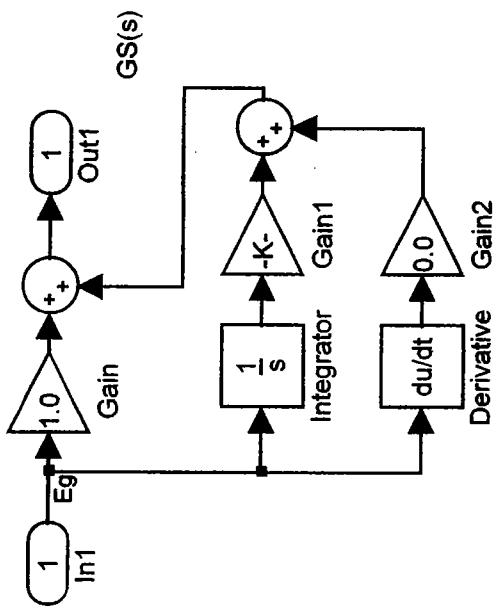

FIGURE 4 BUSINESS PI CONTROLLER

$Kp=1.0$
 $Ki=0.25$

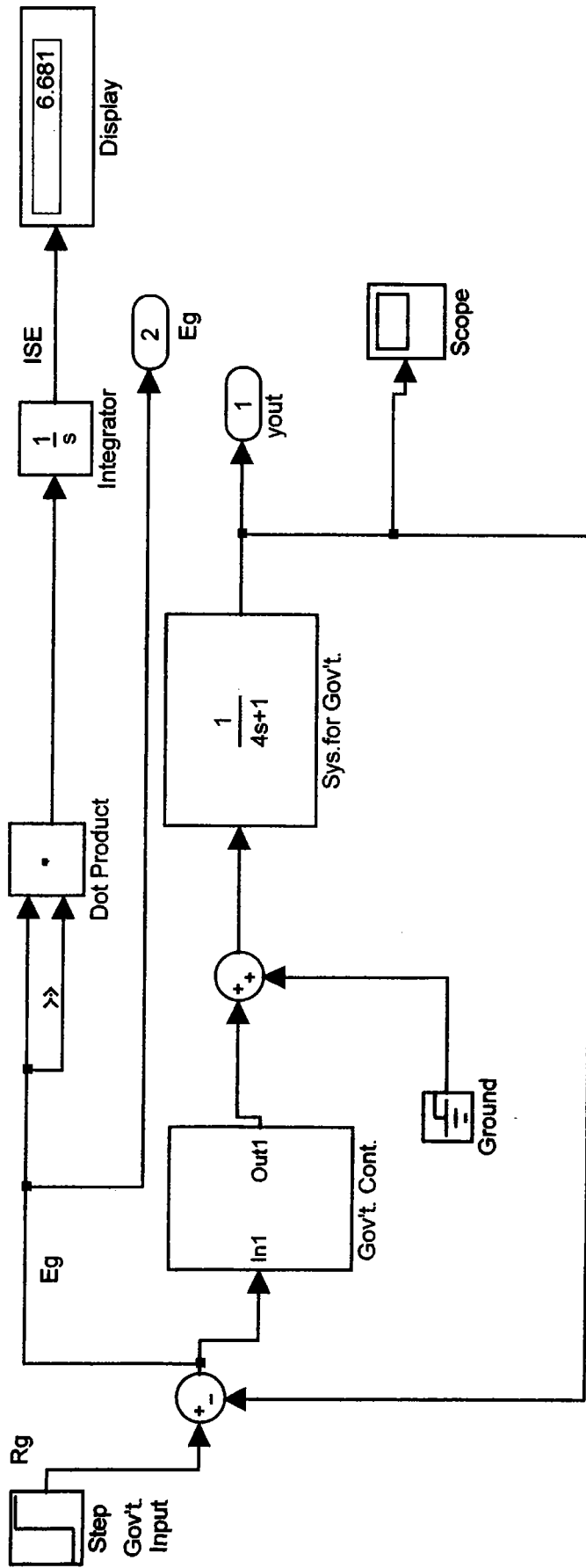

FIGURE 5 ISOLATED GOVERNMENT LOOP

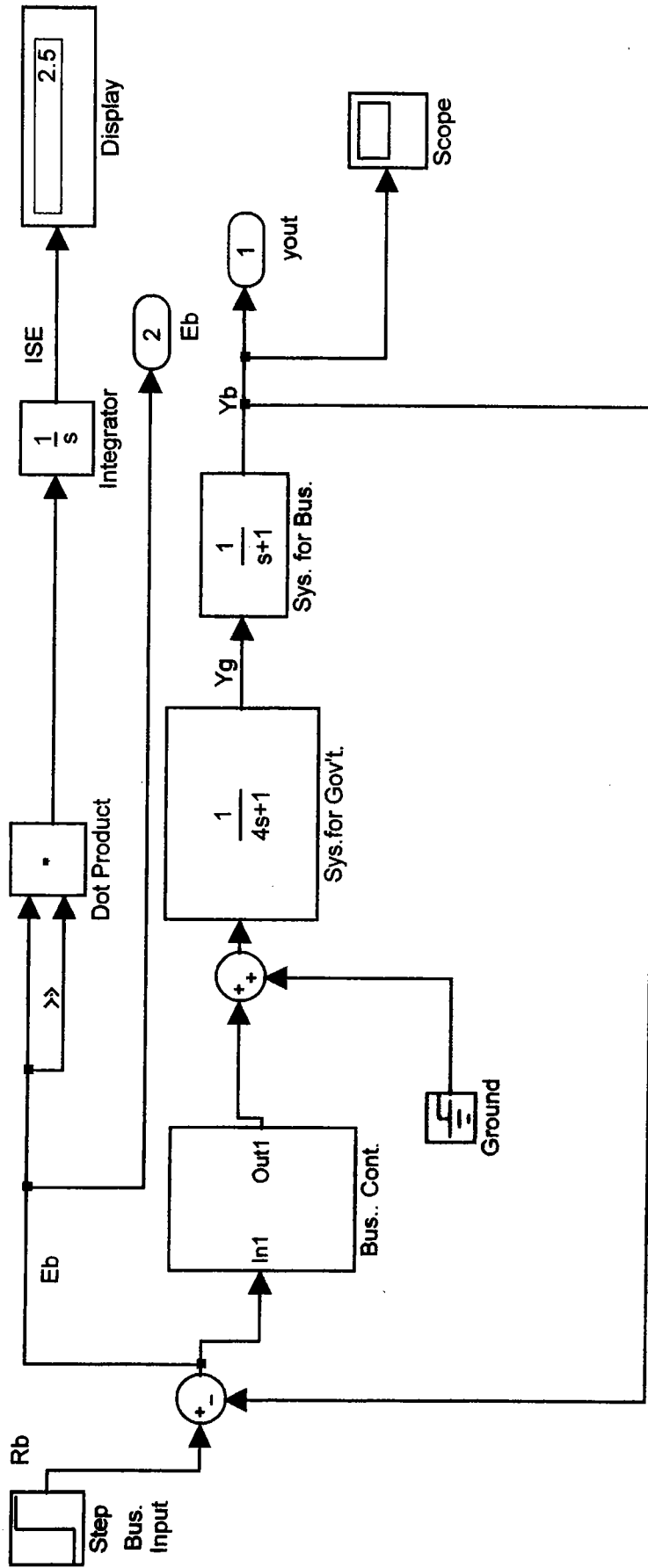

FIGURE 6 ISOLATED BUSINESS LOOP

Step2

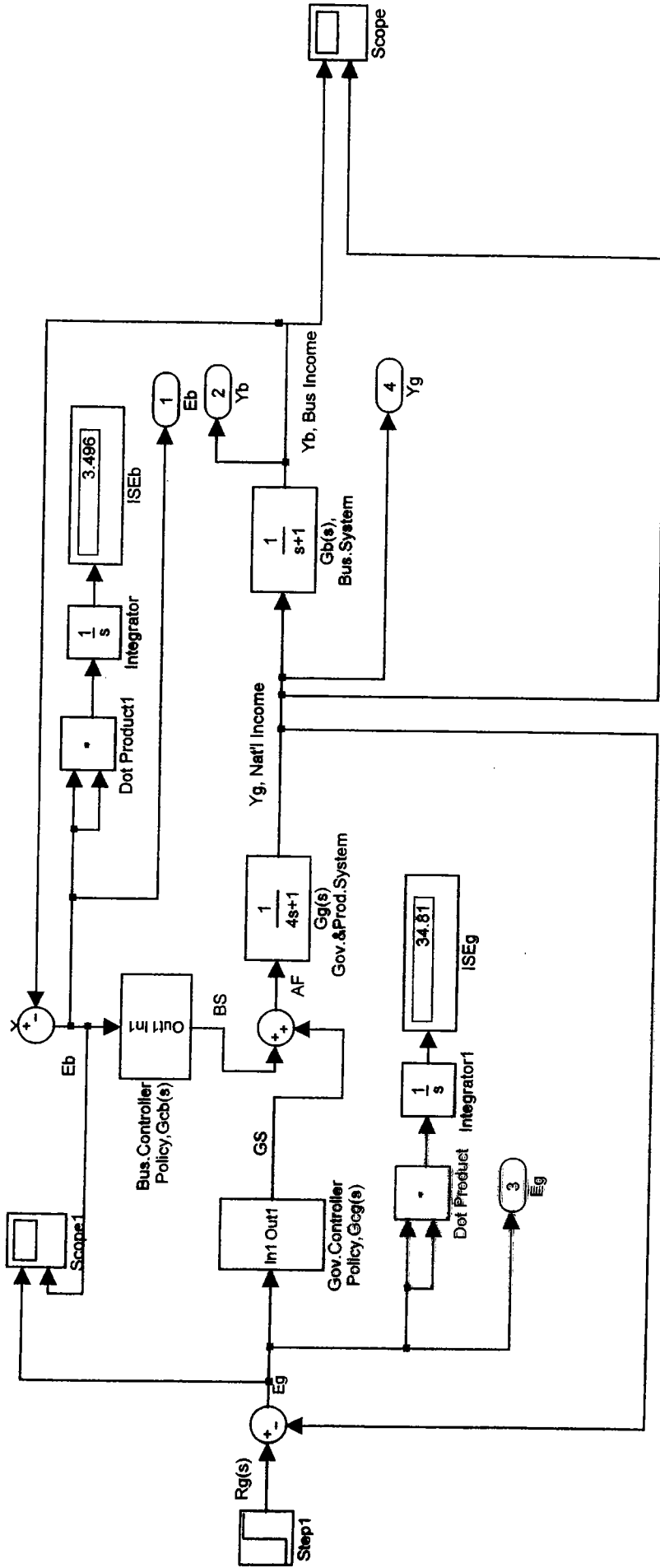

FIGURE 7 ZERO SIGNAL INJECTION FROM BUSINESS WITH SYSTEM MODIFICATION

AF=Available Funds

GS(s)=Gov't Spending

BS= Bus. Spending

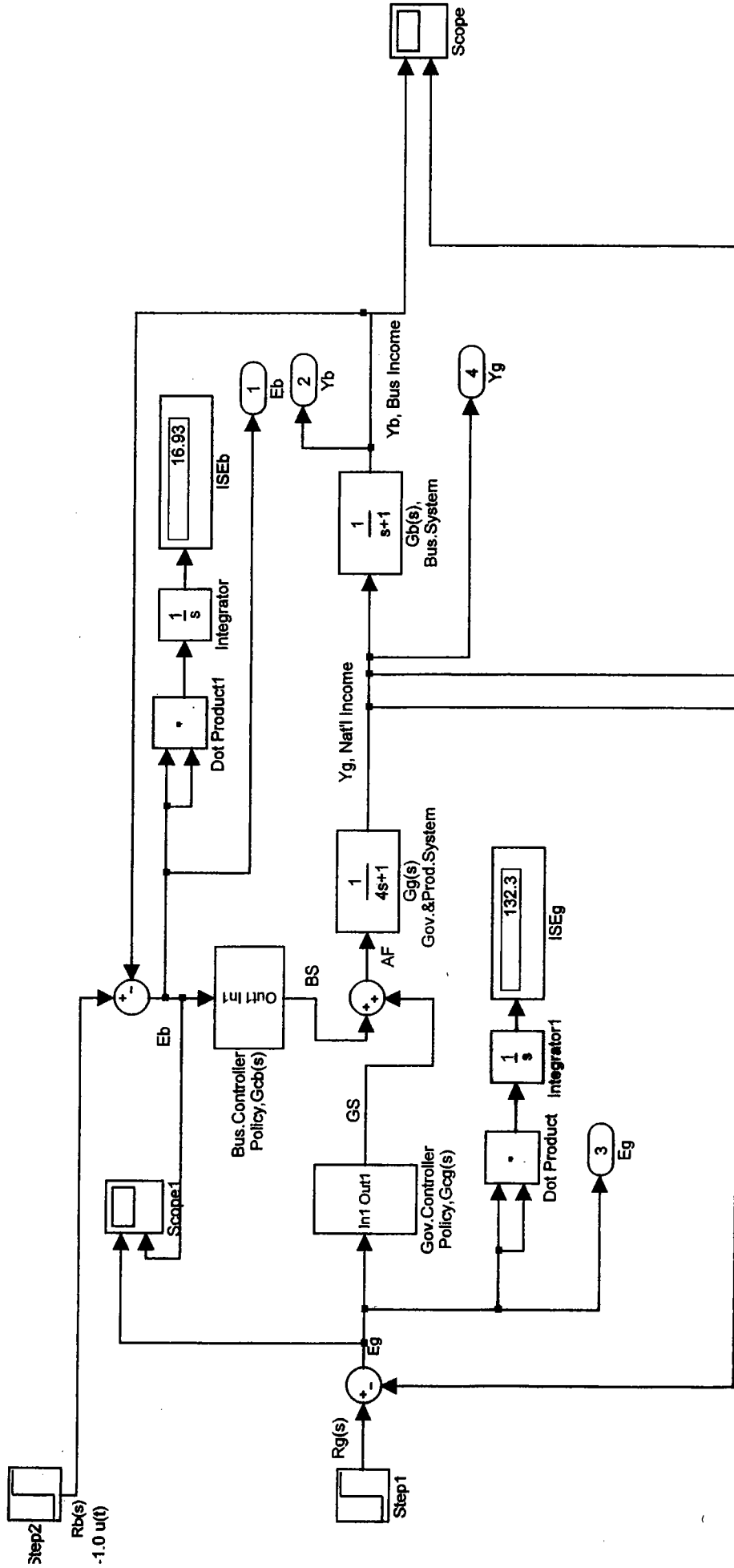
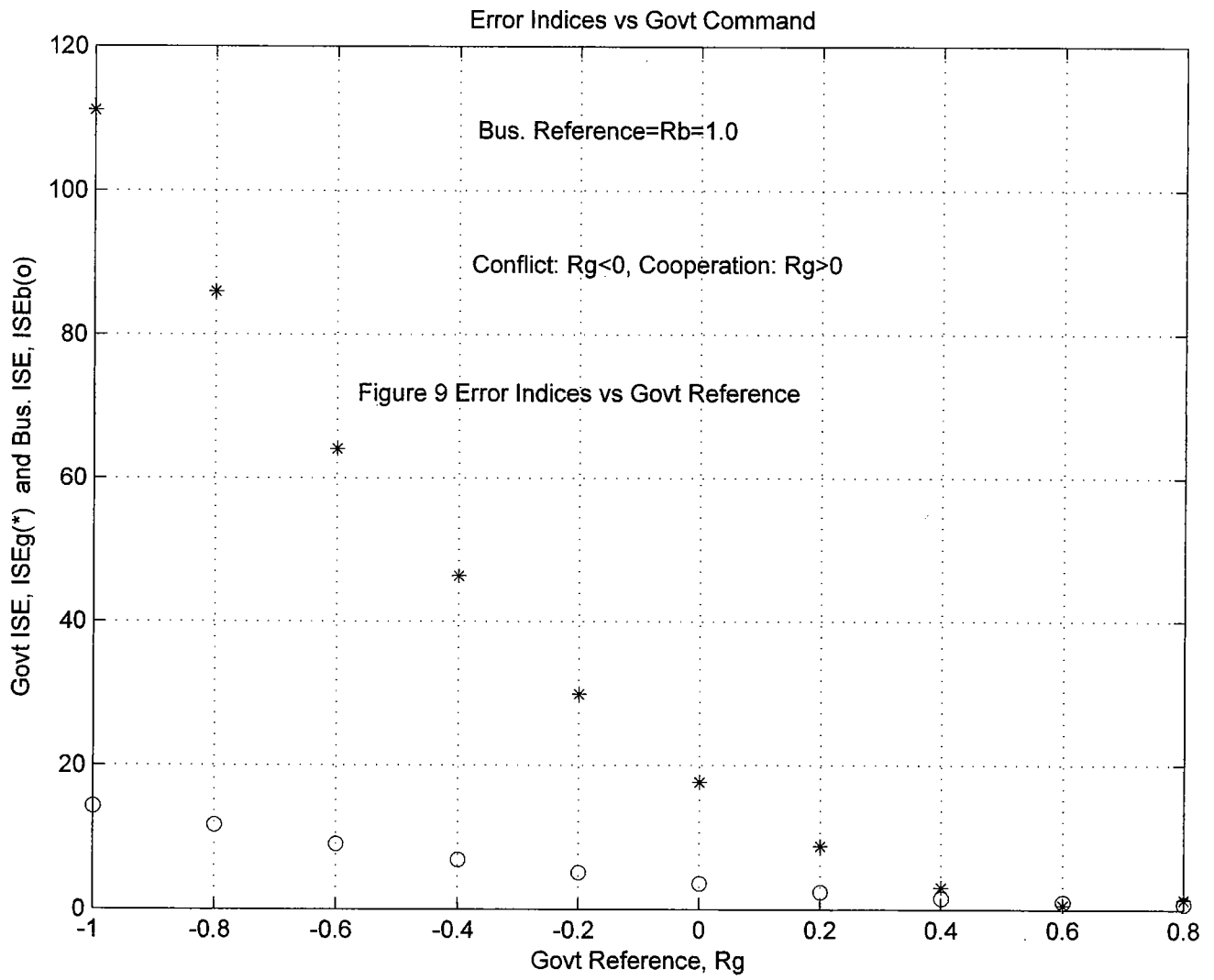

FIGURE 8 EXAMPLE OF CONFLICT THROUGH SIGNAL INJECTION

AF=Available Funds

GS(s)=Gov't Spending

BS= Bus. Spending



Error Indices vs Business Command

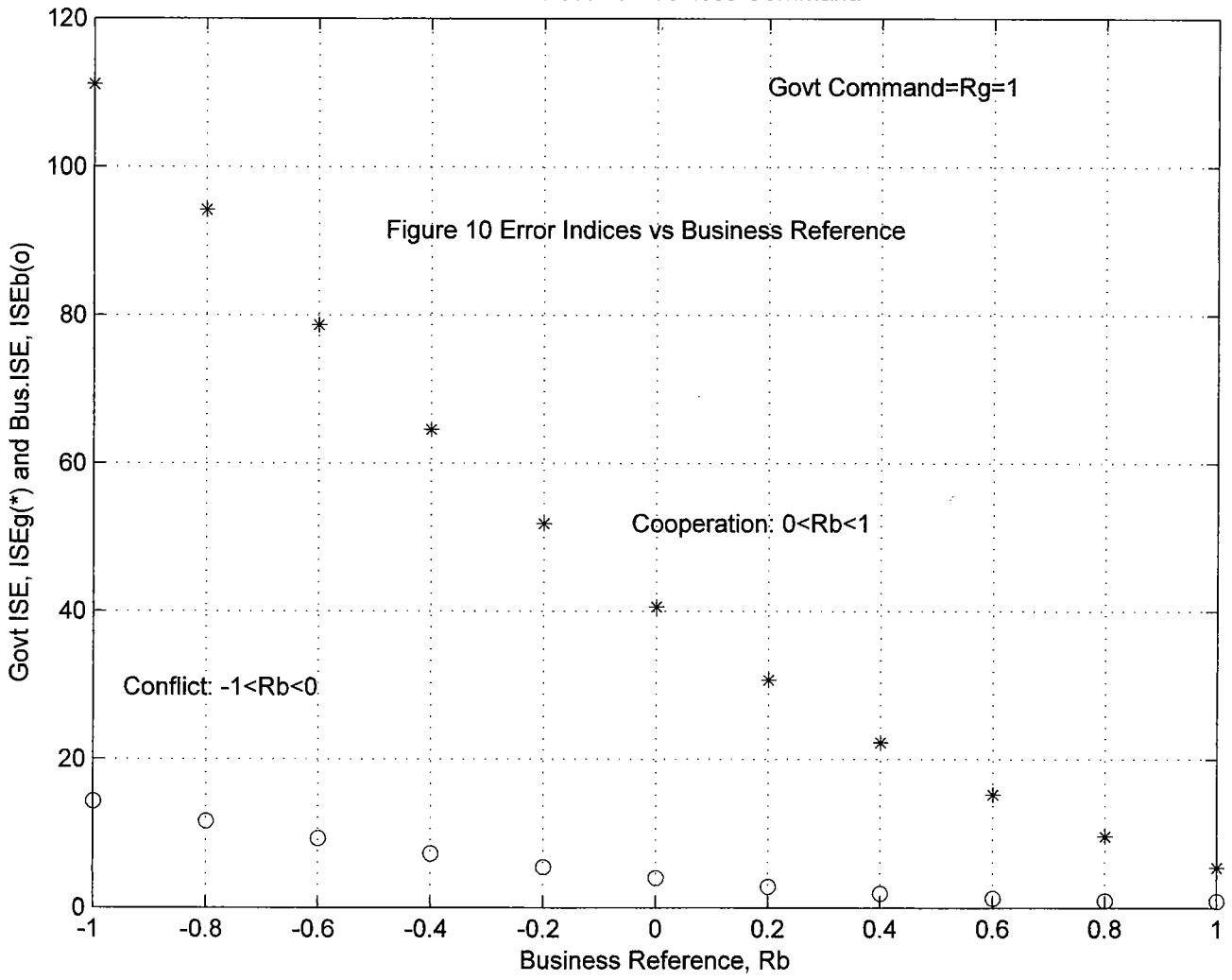

The National Economy as an Example of Control Under Conflict/Cooperation- A Simulation Approach

Robert L. Drake, Ph.D., P.E.
Department of Electrical and Computer Engineering
Christian Brothers University
Memphis, Tennessee
rdrake@cbu.edu

BACKGROUND

The work reported here is the result of teaching a course entitled ECE 488 Modeling and Simulation in Engineering Problems. This course is offered to students in both engineering and non-engineering. All students are required to simulate several dynamic systems during the semester at least one of which must be socio-political-economic (SPE) in nature. As instructor of the course, the writer chose the initial model of the national economy as an example of SPE systems to present to the class. This model was taken from reference [1] initially, and then as discussion progressed “refinements” were added. One of these refinements were reported in an earlier paper [2], where additional work suggested includes that of possible conflicts between the goals of government and the goals of business. The work reported here is the first attempt of the writer to approach that problem.

MODEL

The model hypothesized in this work is shown in the block diagram of Figure 1. Although inspired by the model suggested in reference [1], the model differs in several respects, among which are the inclusion of business investment as a separate input of the two-input system, identification of separate decision-making (controllers) for government and business, identification of different performance indices for government and business, and inclusion of two distinct outputs from the system. The inputs to the system are shown as business reference input (R_b) and the government reference input (R_g). The outputs from the system are shown as the national income level (Y_g) and the business income level (Y_b).

Figure 2 shows the identification of two performance indices chosen in this study. The performance index for government is based on the error, or difference, between the desired change in national income level and the measured change, E_g . In this case the integral squared value of this error is taken as the performance index. For business the error, or difference, is E_b as measured by the desired change in business income and the actual value. Again, the integral squared value of this error is used as the performance index.

Figure 3 shows the proportional plus integral (PI) controller chosen for the government controller. The controller constants were chosen to provide critical damping for the isolated government system. The government system is defined as isolated when the business input is set to zero (command for no change) and the business spending signal (BS) is set to zero. The simulation of the isolated government loop is shown in Figure 5 along with the indicated integral square error (ISE_g) of 6.681 for the unit step response which can be checked with theory for this particular index of performance. Figure 4 shows the PI controller chosen for the isolated business loop and Figure 6 shows the simulation result for this case where the ISE_b is 2.5 which also is checked by application of theory.

In Figure 1 the system representing government and production operations is shown with time constant of 4 time units and “dc” gain of 1. The system representing business operations is shown with time constant of 1 time unit and gain of 1.

DEFINITION OF CONFLICT AND COOPERATION

In Figure 2 the goal of government is to reduce as much as possible the performance index defined in this case as the integral square of the error signal E_g shown as ISE_g. The goal of business is to reduce ISE_b as much as possible. In the model shown, there is coupling between the government loop and the business loop with the result that propagation of signals in one loop affects the operation of the second loop. In the context of this work, conflict is defined to exist if the effect of the first loop upon the second loop is such that the performance index of the second is worsened, or increased in this case where the goal is to decrease the ISE. Similarly, cooperation is defined to exist if the coupling effect improves the performance index.

Simulation makes obvious that conflict and cooperation can exist because of signal injection or because of system modification without signal injection, or both. In Figure 7 no signal is injected by the business system, but because of the presence of the business feedback loop the government performance index ISE_g is increased by a factor of (34.81/6.68), or 5.2 to 1. By the definition above, conflict exists. On the other hand, in Figure 8 signal injection at the business reference input R_b along with the feedback in the business loop results in ISE_g increase by a factor of (132.3/6.68), or 19.8 to 1. Conflict from signal injection in this case results from the opposite signs in the reference input to the government loop and reference input to the business loop.

ADDITIONAL SIMULATION RESULTS

Additional simulation results are shown in Figures 9 and 10. Figure 9 shows the variation of the performance indices ISE_g and ISE_b with government reference R_g with business reference R_b held constant at unity. By the definitions above for cooperation and conflict,

cooperation increases as R_g varies from 0 to 1 and conflict increases as R_g varies from 0 to -1. There is a rapid increase in the error indices as the conflict increases and a rapid decrease in the error indices as the cooperation increases. Figure 10 shows the variation of the error indices as a function of the business reference R_b with the government reference held constant at unity. Again, there is a rapid increase in error indices as conflict increases and a rapid decrease in error indices as cooperation increases.

SUMMARY AND CONCLUSIONS

(1) Conflict may be defined by the actions of one participant, say business, tending to increase the performance index being minimized by the second participant, say government. Cooperation may be defined as existing when the actions of one of the participants tends to reduce the performance index being minimized by the second participant.

(2) Cooperation/conflict may result from either signal injection or from system modification, or both.

FUTURE WORK

(1) The effects of consumers should be added to the model. With three participants present, the possibility of joint cooperation/conflict arises. Include the effect of foreign investment.

(2) Practical data and reasonable scaling limits should be added. This probably requires participation of personnel with backgrounds in business and economics.

(3) Re-phrase the problem in terms of state variables and vector-matrix operations. Use modern control theory to re-design the controllers. Consider the possibility of decoupling output except from one input.

FINAL COMMENTS

(1) This is a work in progress.

(2) Results and conclusions, although believed to be original, are preliminary and should be considered as such.

REFERENCES

- [1] S.M. Shinnars, Modern Control Theory and Application, Reading, MA, Addison-Wesley, 1972.
- [2] R.L. Drake, "Do Checks and Balances Contribute to Cycles in the Economy?", MAESC 2003, Christian Brothers University, Memphis, TN, May 15, 2003.

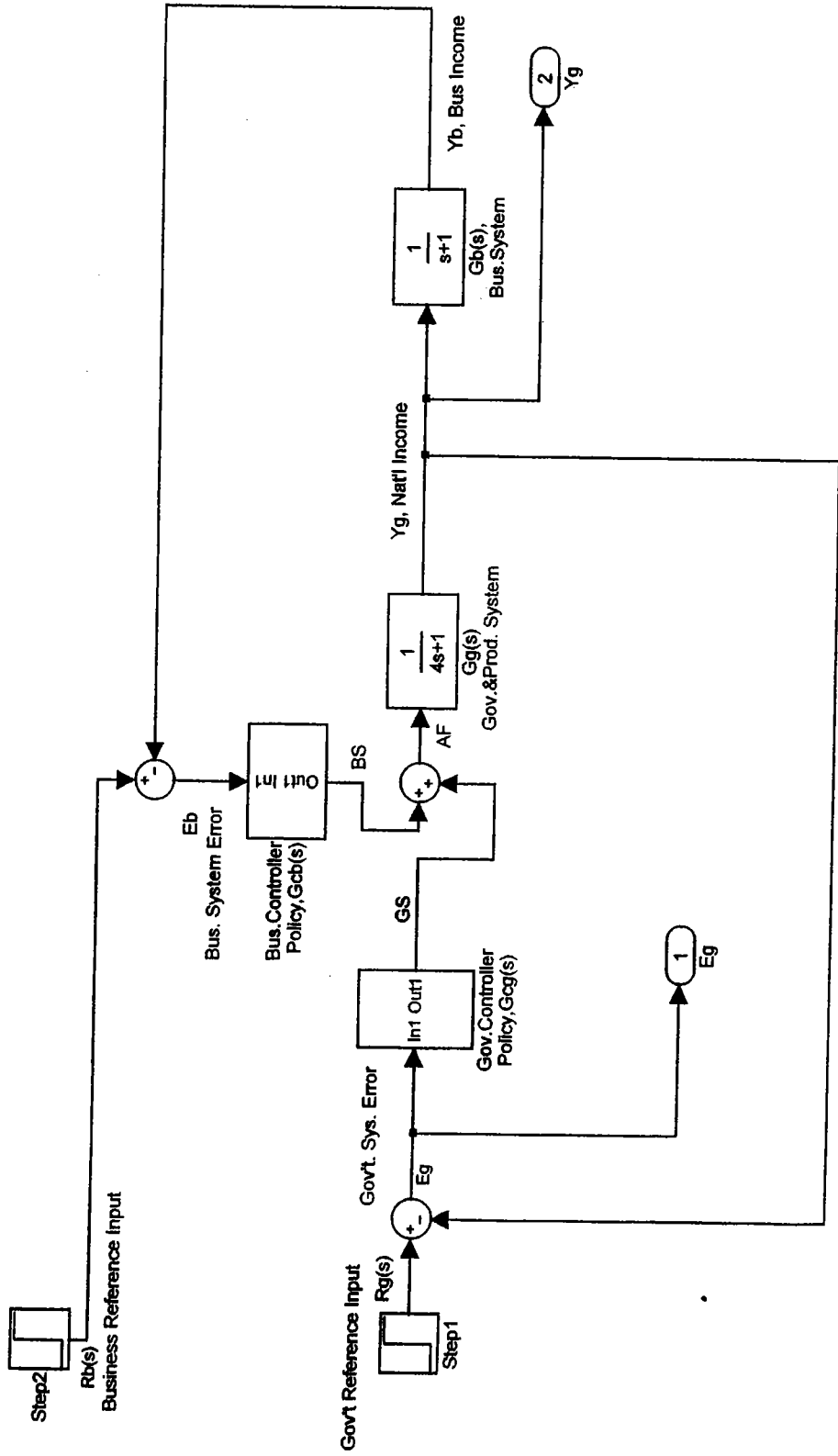

FIGURE 1 BLOCK DIAGRAM

AF=Available Funds
 GS(s)=Gov't Spending
 BS= Bus. Spending

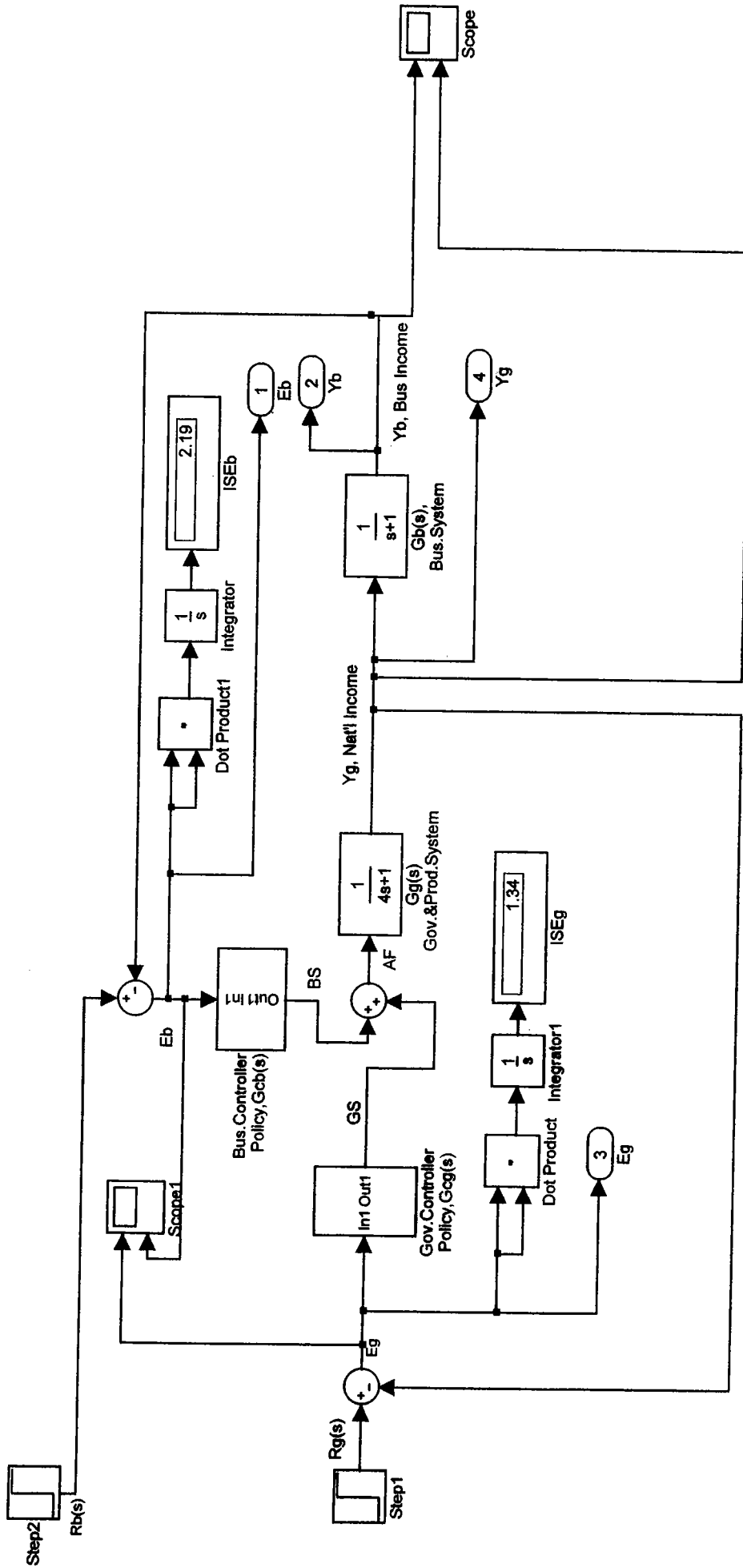

FIGURE 2 BLOCK DIAGRAM with VIRTUAL INSTRUMENTATION and COMPUTATION

AF=Available Funds
 GS(s)=Gov't Spending
 BS= Bus. Spending

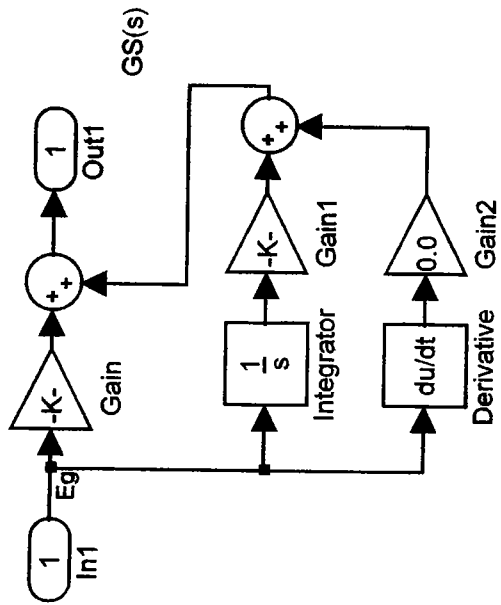

FIGURE 3 GOVERNMENT PI CONTROLLER

$K_p=0.1716$

$K_i=0.0858$

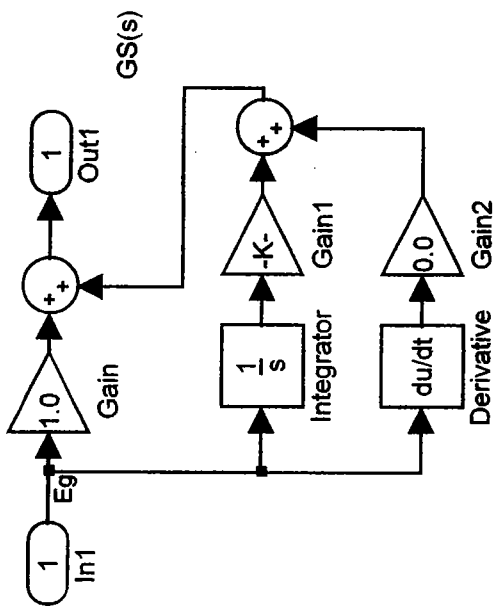

FIGURE 4 BUSINESS PI CONTROLLER

$Kp=1.0$
 $Ki=0.25$

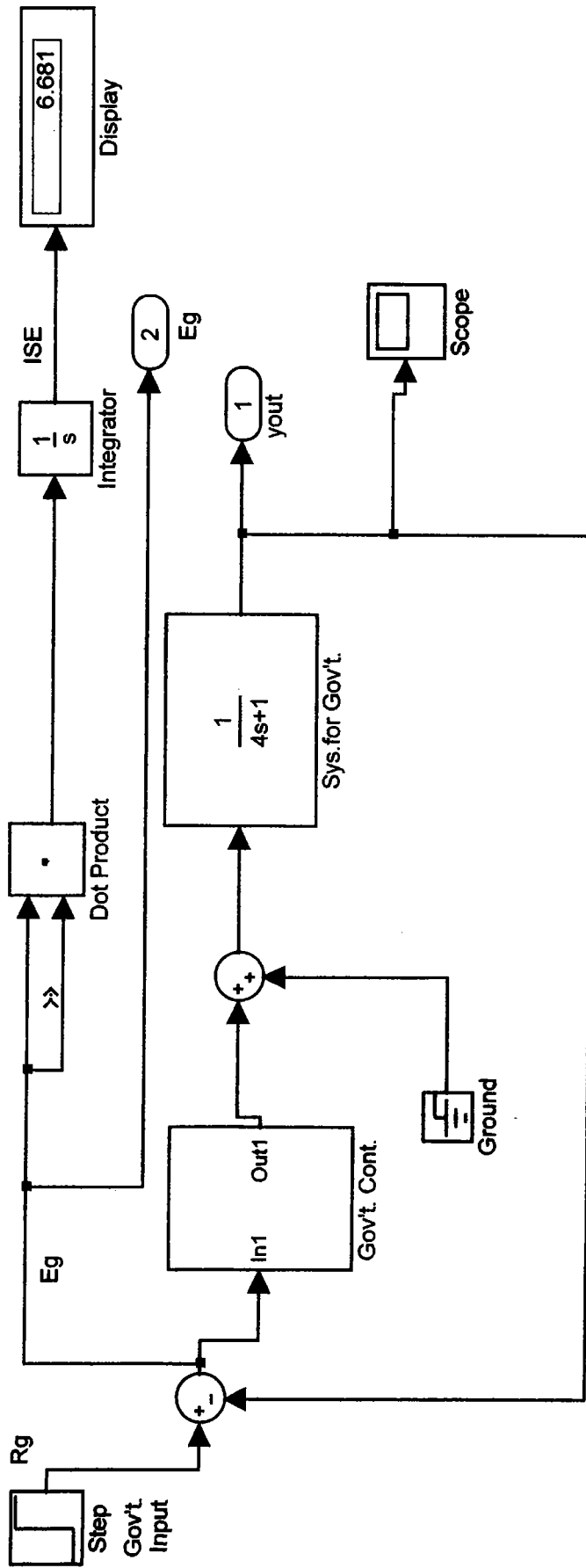

FIGURE 5 ISOLATED GOVERNMENT LOOP

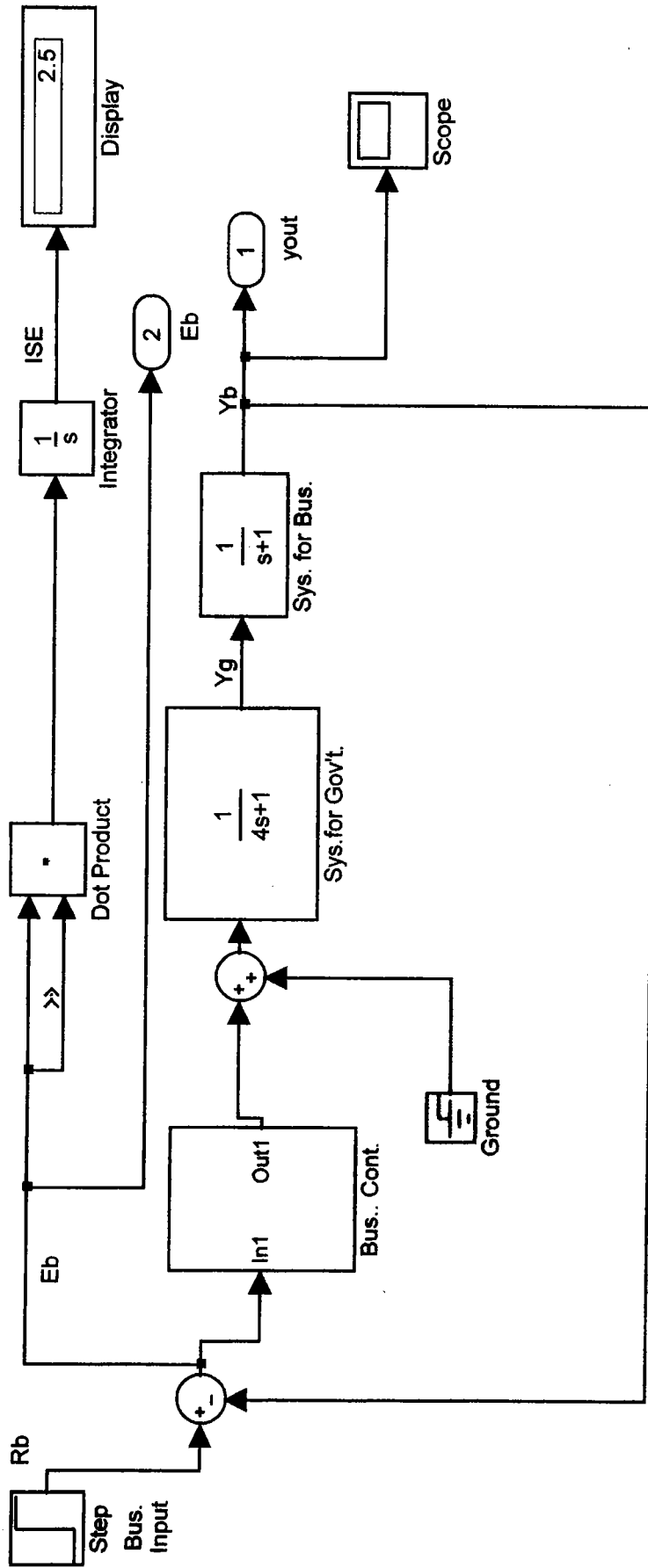

FIGURE 6 ISOLATED BUSINESS LOOP

Step2

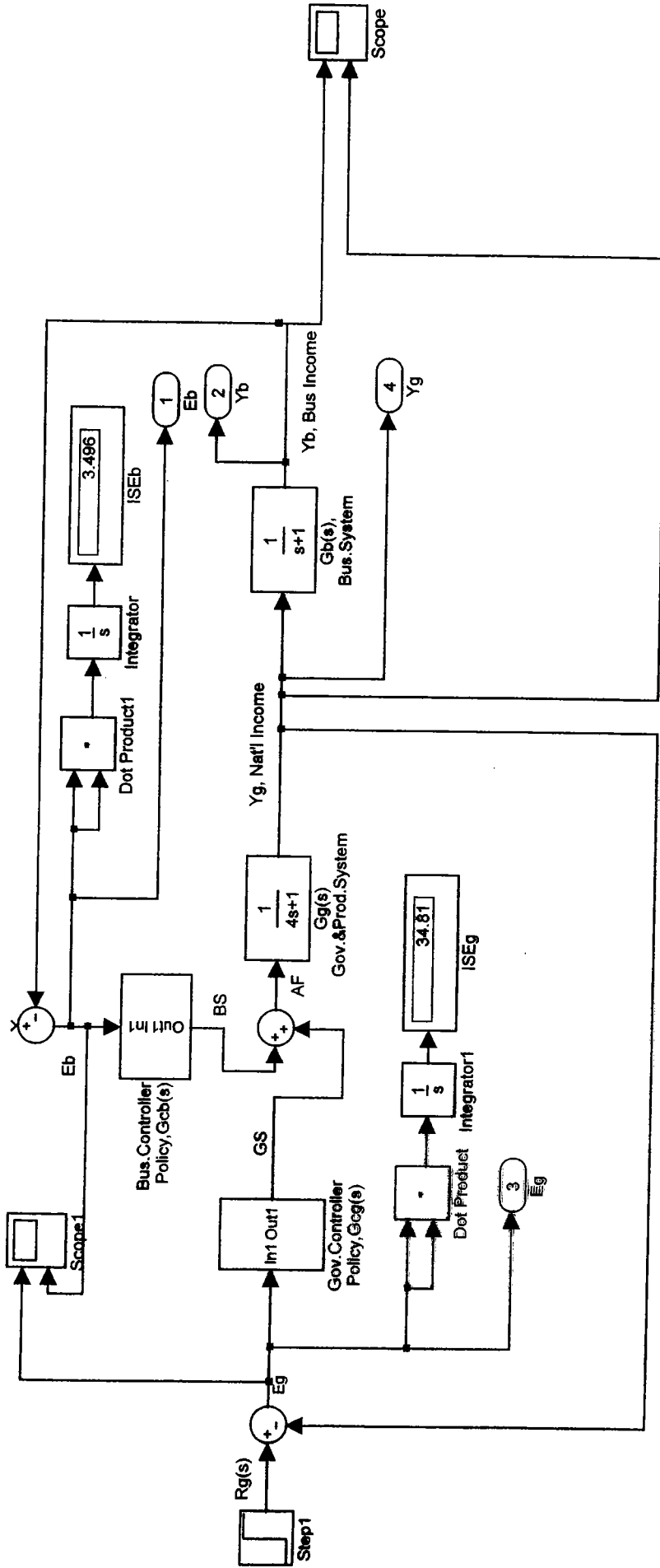

FIGURE 7 ZERO SIGNAL INJECTION FROM BUSINESS WITH SYSTEM MODIFICATION

AF=Available Funds

$G_b(s)$ =Gov't Spending

BS= Bus. Spending

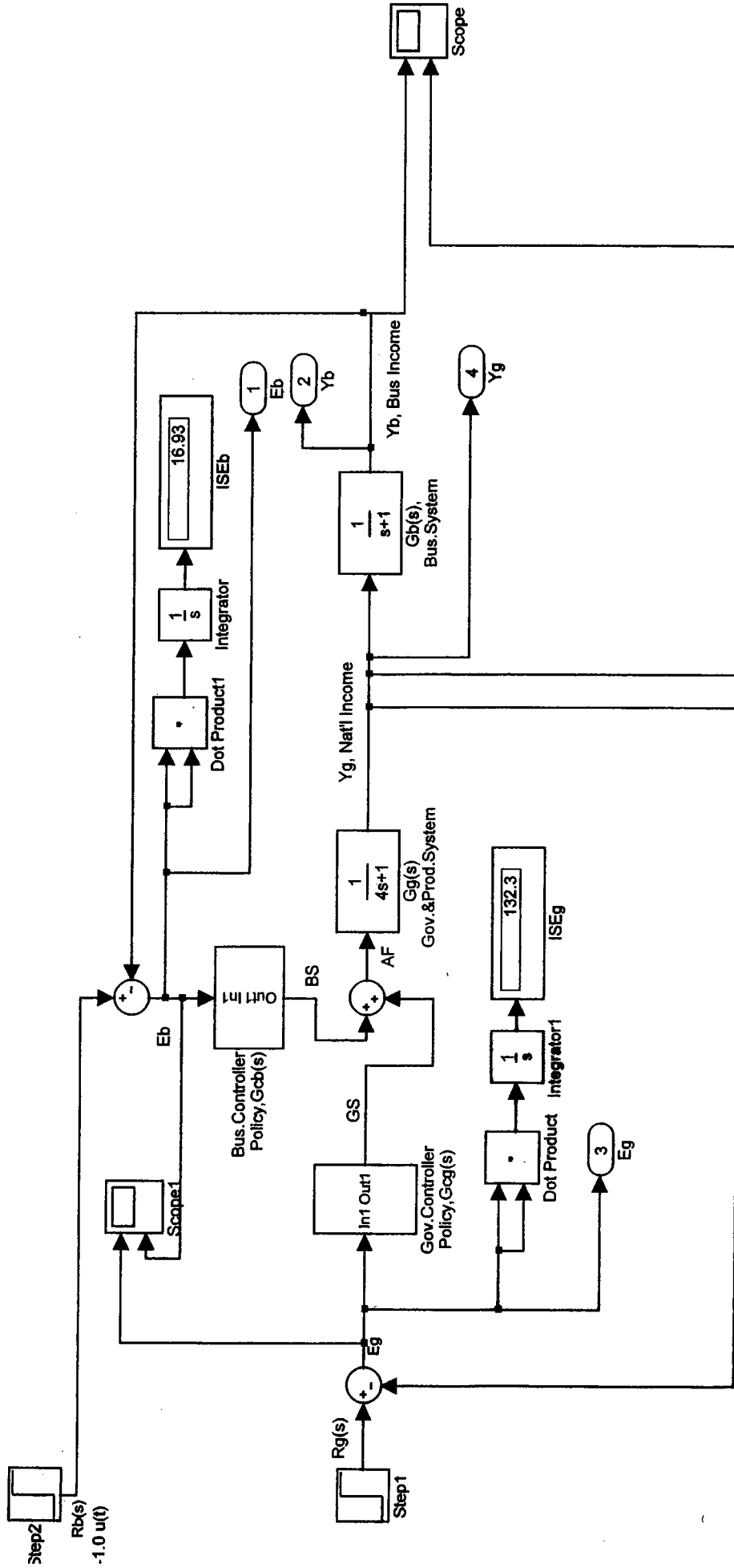
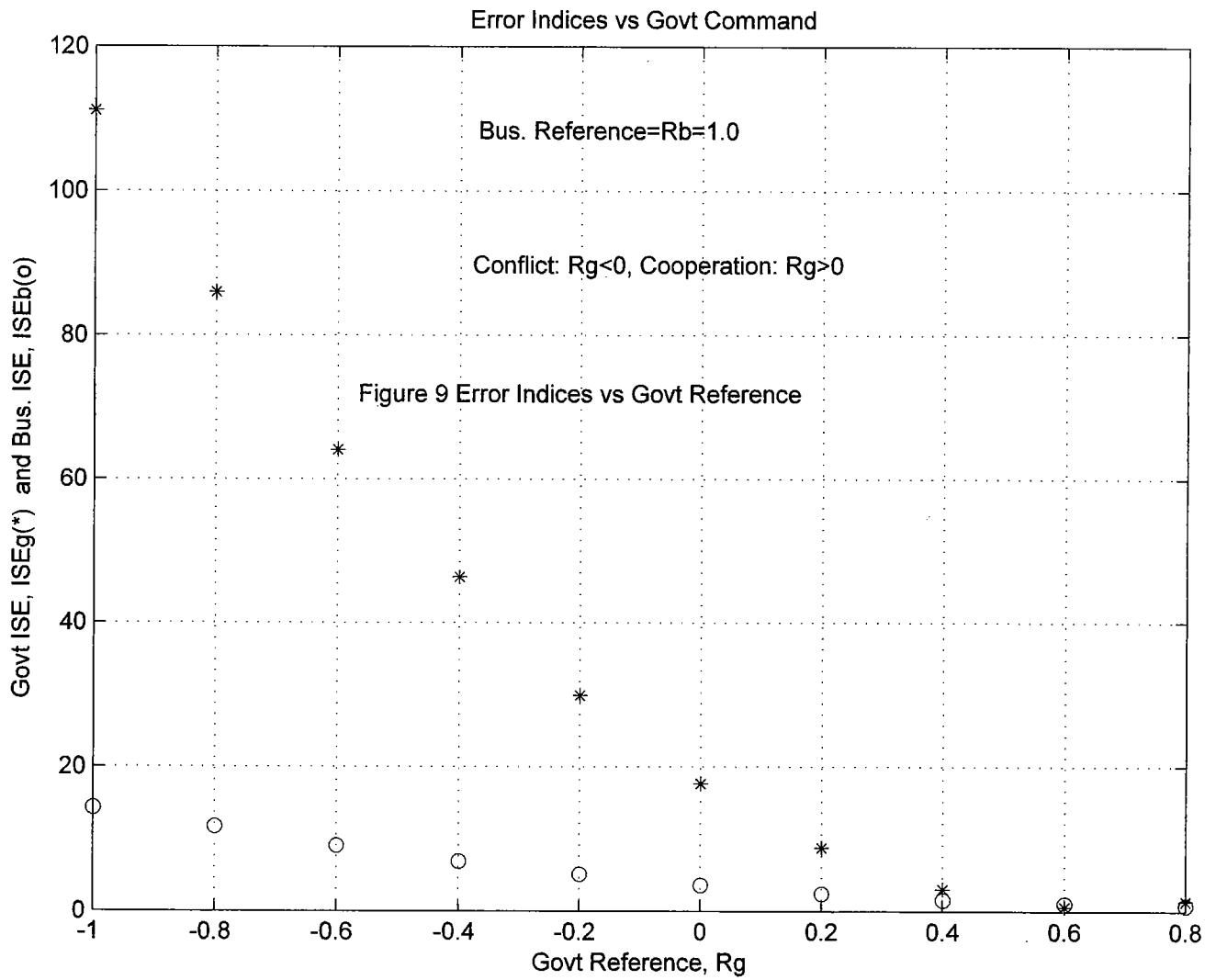

FIGURE 8 EXAMPLE OF CONFLICT THROUGH SIGNAL INJECTION

AF=Available Funds

GS(s)=Gov't
Spending

BS= Bus. Spending



Error Indices vs Business Command

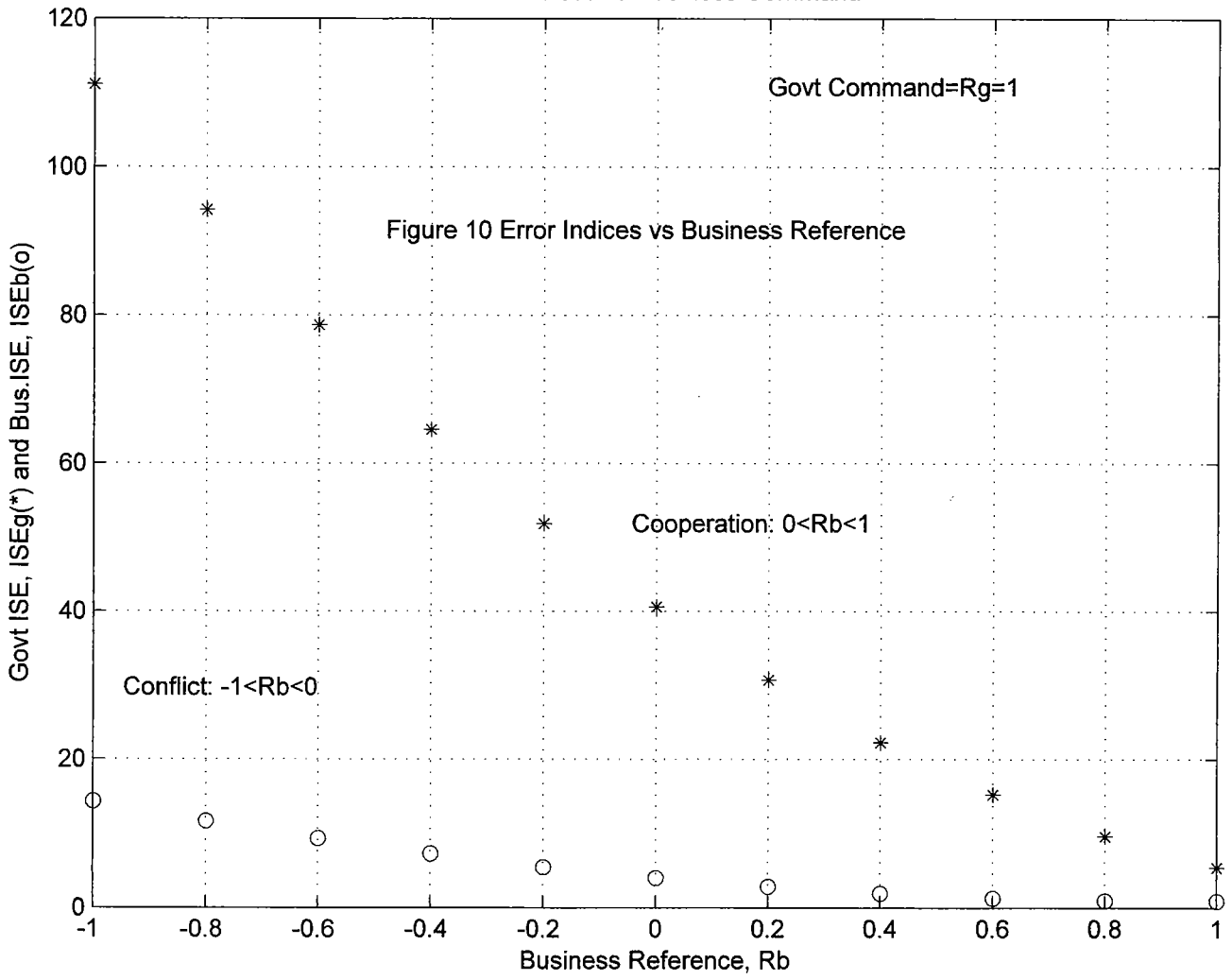

The National Economy as an Example of Control Under Conflict/Cooperation- A Simulation Approach

Robert L. Drake, Ph.D., P.E.
Department of Electrical and Computer Engineering
Christian Brothers University
Memphis, Tennessee
rdrake@cbu.edu

BACKGROUND

The work reported here is the result of teaching a course entitled ECE 488 Modeling and Simulation in Engineering Problems. This course is offered to students in both engineering and non-engineering. All students are required to simulate several dynamic systems during the semester at least one of which must be socio-political-economic (SPE) in nature. As instructor of the course, the writer chose the initial model of the national economy as an example of SPE systems to present to the class. This model was taken from reference [1] initially, and then as discussion progressed “refinements” were added. One of these refinements were reported in an earlier paper [2], where additional work suggested includes that of possible conflicts between the goals of government and the goals of business. The work reported here is the first attempt of the writer to approach that problem.

MODEL

The model hypothesized in this work is shown in the block diagram of Figure 1. Although inspired by the model suggested in reference [1], the model differs in several respects, among which are the inclusion of business investment as a separate input of the two-input system, identification of separate decision-making (controllers) for government and business, identification of different performance indices for government and business, and inclusion of two distinct outputs from the system. The inputs to the system are shown as business reference input (R_b) and the government reference input (R_g). The outputs from the system are shown as the national income level (Y_g) and the business income level (Y_b).

Figure 2 shows the identification of two performance indices chosen in this study. The performance index for government is based on the error, or difference, between the desired change in national income level and the measured change, E_g . In this case the integral squared value of this error is taken as the performance index. For business the error, or difference, is E_b as measured by the desired change in business income and the actual value. Again, the integral squared value of this error is used as the performance index.

Figure 3 shows the proportional plus integral (PI) controller chosen for the government controller. The controller constants were chosen to provide critical damping for the isolated government system. The government system is defined as isolated when the business input is set to zero (command for no change) and the business spending signal (BS) is set to zero. The simulation of the isolated government loop is shown in Figure 5 along with the indicated integral square error (ISEg) of 6.681 for the unit step response which can be checked with theory for this particular index of performance. Figure 4 shows the PI controller chosen for the isolated business loop and Figure 6 shows the simulation result for this case where the ISEb is 2.5 which also is checked by application of theory.

In Figure 1 the system representing government and production operations is shown with time constant of 4 time units and “dc” gain of 1. The system representing business operations is shown with time constant of 1 time unit and gain of 1.

DEFINITION OF CONFLICT AND COOPERATION

In Figure 2 the goal of government is to reduce as much as possible the performance index defined in this case as the integral square of the error signal E_g shown as ISEg. The goal of business is to reduce ISEb as much as possible. In the model shown, there is coupling between the government loop and the business loop with the result that propagation of signals in one loop affects the operation of the second loop. In the context of this work, conflict is defined to exist if the effect of the first loop upon the second loop is such that the performance index of the second is worsened, or increased in this case where the goal is to decrease the ISE. Similarly, cooperation is defined to exist if the coupling effect improves the performance index.

Simulation makes obvious that conflict and cooperation can exist because of signal injection or because of system modification without signal injection, or both. In Figure 7 no signal is injected by the business system, but because of the presence of the business feedback loop the government performance index ISEg is increased by a factor of $(34.81/6.68)$, or 5.2 to 1. By the definition above, conflict exists. On the other hand, in Figure 8 signal injection at the business reference input R_b along with the feedback in the business loop results in ISEg increase by a factor of $(132.3/6.68)$, or 19.8 to 1. Conflict from signal injection in this case results from the opposite signs in the reference input to the government loop and reference input to the business loop.

ADDITIONAL SIMULATION RESULTS

Additional simulation results are shown in Figures 9 and 10. Figure 9 shows the variation of the performance indices ISEg and ISEb with government reference R_g with business reference R_b held constant at unity. By the definitions above for cooperation and conflict,

cooperation increases as R_g varies from 0 to 1 and conflict increases as R_g varies from 0 to -1. There is a rapid increase in the error indices as the conflict increases and a rapid decrease in the error indices as the cooperation increases. Figure 10 shows the variation of the error indices as a function of the business reference R_b with the government reference held constant at unity. Again, there is a rapid increase in error indices as conflict increases and a rapid decrease in error indices as cooperation increases.

SUMMARY AND CONCLUSIONS

(1) Conflict may be defined by the actions of one participant, say business, tending to increase the performance index being minimized by the second participant, say government. Cooperation may be defined as existing when the actions of one of the participants tends to reduce the performance index being minimized by the second participant.

(2) Cooperation/conflict may result from either signal injection or from system modification, or both.

FUTURE WORK

(1) The effects of consumers should be added to the model. With three participants present, the possibility of joint cooperation/conflict arises. Include the effect of foreign investment.

(2) Practical data and reasonable scaling limits should be added. This probably requires participation of personnel with backgrounds in business and economics.

(3) Re-phrase the problem in terms of state variables and vector-matrix operations. Use modern control theory to re-design the controllers. Consider the possibility of decoupling output except from one input.

FINAL COMMENTS

(1) This is a work in progress.

(2) Results and conclusions, although believed to be original, are preliminary and should be considered as such.

REFERENCES

- [1] S.M. Shinnars, Modern Control Theory and Application, Reading, MA, Addison-Wesley, 1972.
- [2] R.L. Drake, "Do Checks and Balances Contribute to Cycles in the Economy?", MAESC 2003, Christian Brothers University, Memphis, TN, May 15, 2003.

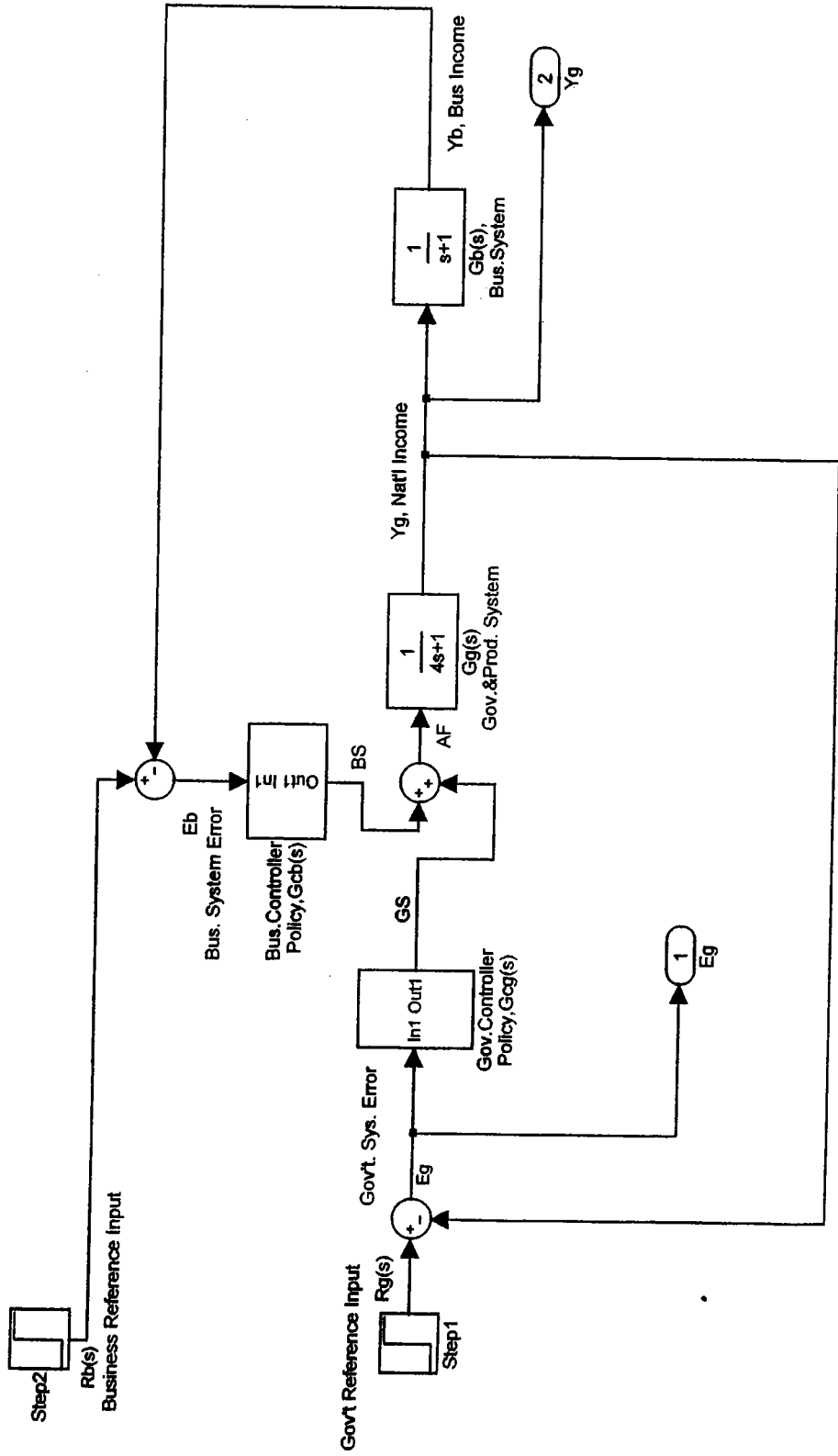

FIGURE 1 BLOCK DIAGRAM

AF=Available Funds
 GS(s)=Gov't Spending
 BS= Bus. Spending

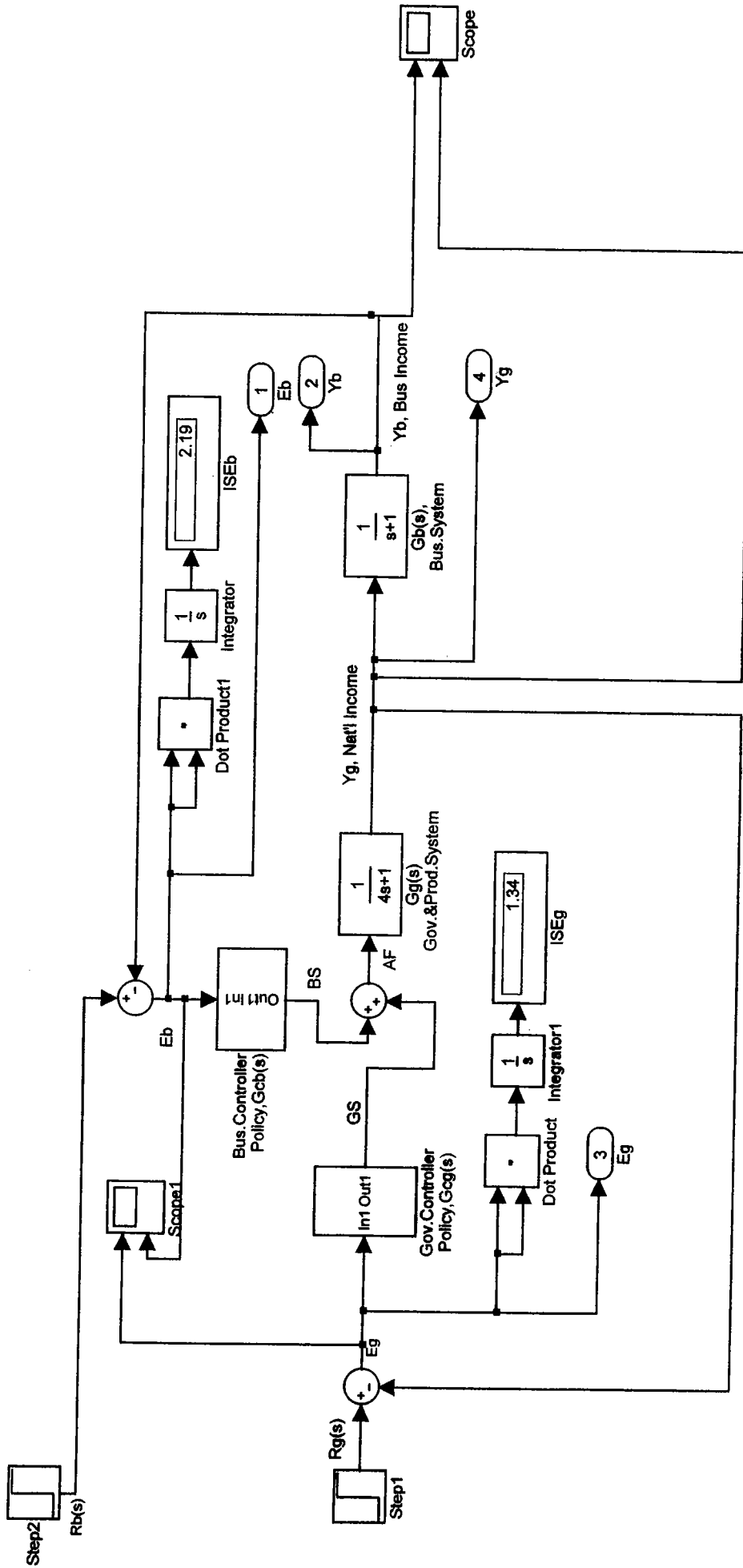

FIGURE 2 BLOCK DIAGRAM with VIRTUAL INSTRUMENTATION and COMPUTATION

AF=Available Funds
 GS(s)=Gov't Spending
 BS= Bus. Spending

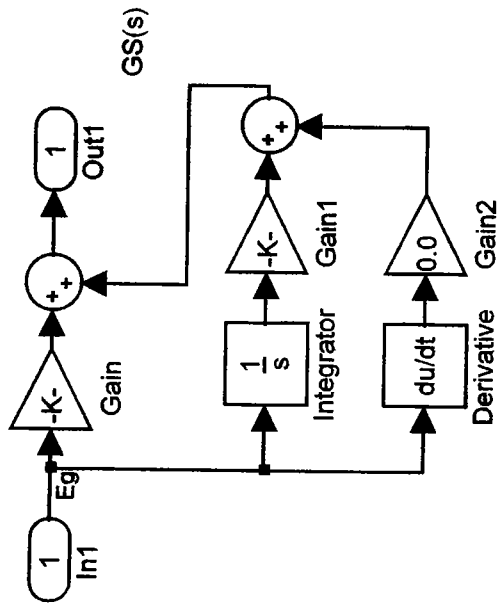

FIGURE 3 GOVERNMENT PI CONTROLLER

Kp=0.1716

Ki=0.0858

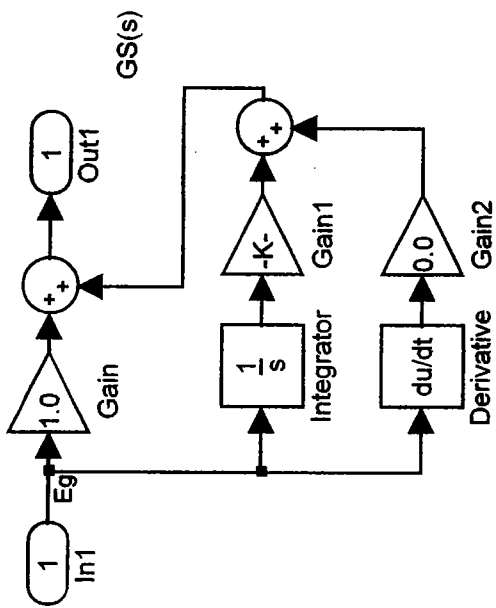

FIGURE 4 BUSINESS PI CONTROLLER

$K_p=1.0$
 $K_i=0.25$

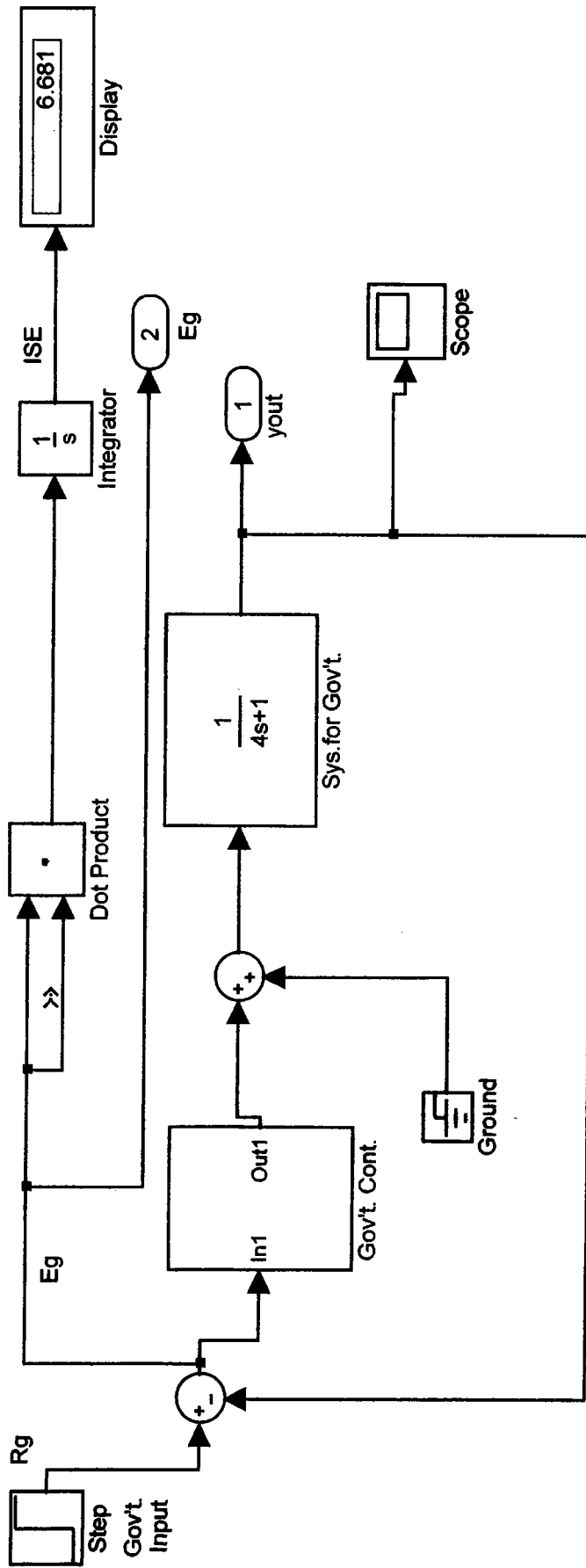

FIGURE 5 ISOLATED GOVERNMENT LOOP

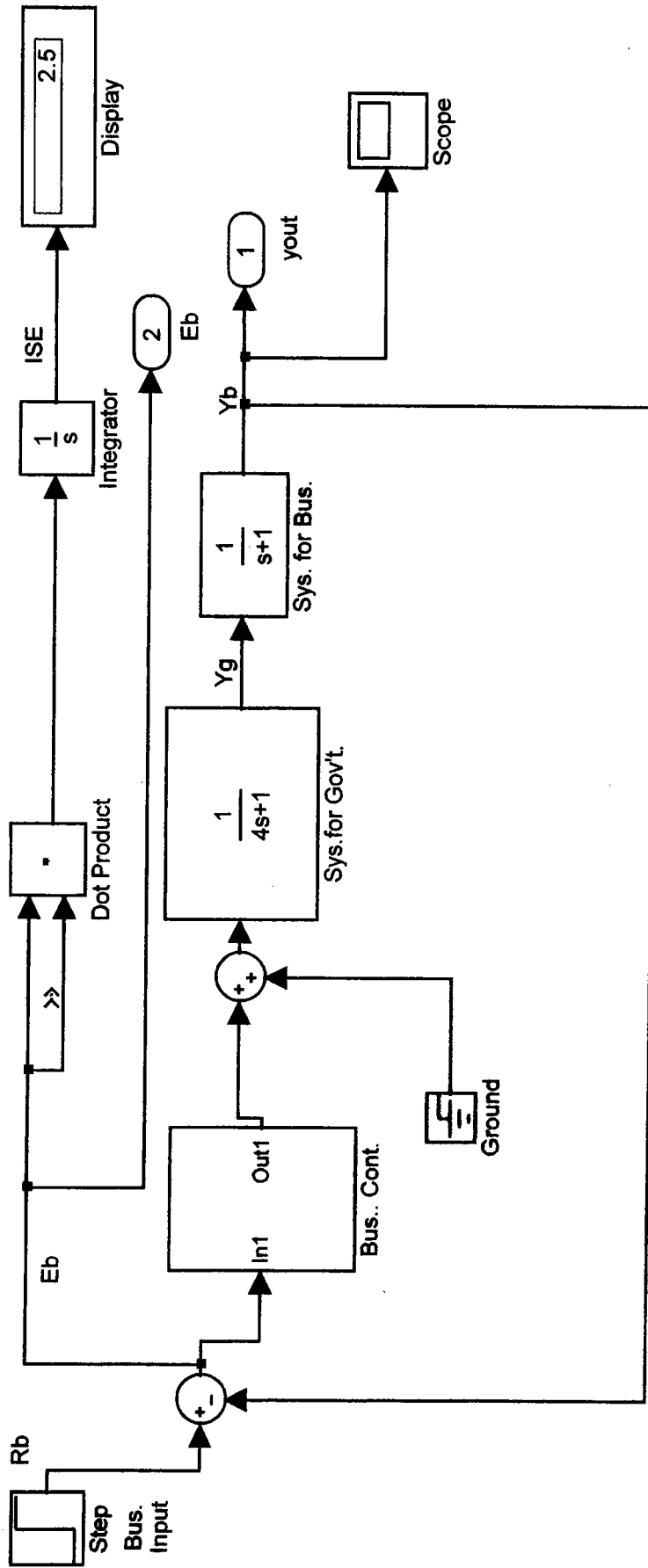

FIGURE 6 ISOLATED BUSINESS LOOP

Step2

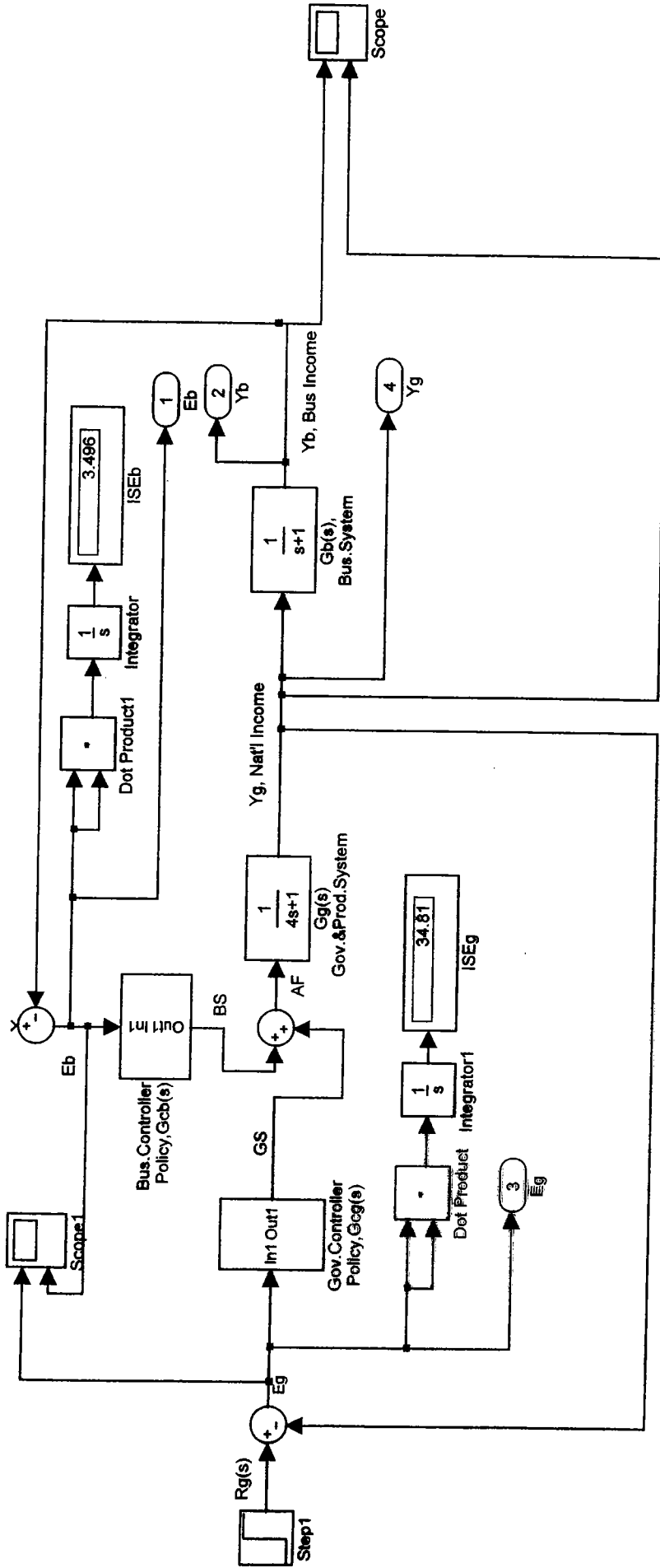

FIGURE 7 ZERO SIGNAL INJECTION FROM BUSINESS WITH SYSTEM MODIFICATION

AF=Available Funds

$GS(s)$ =Gov't Spending

BS = Bus. Spending

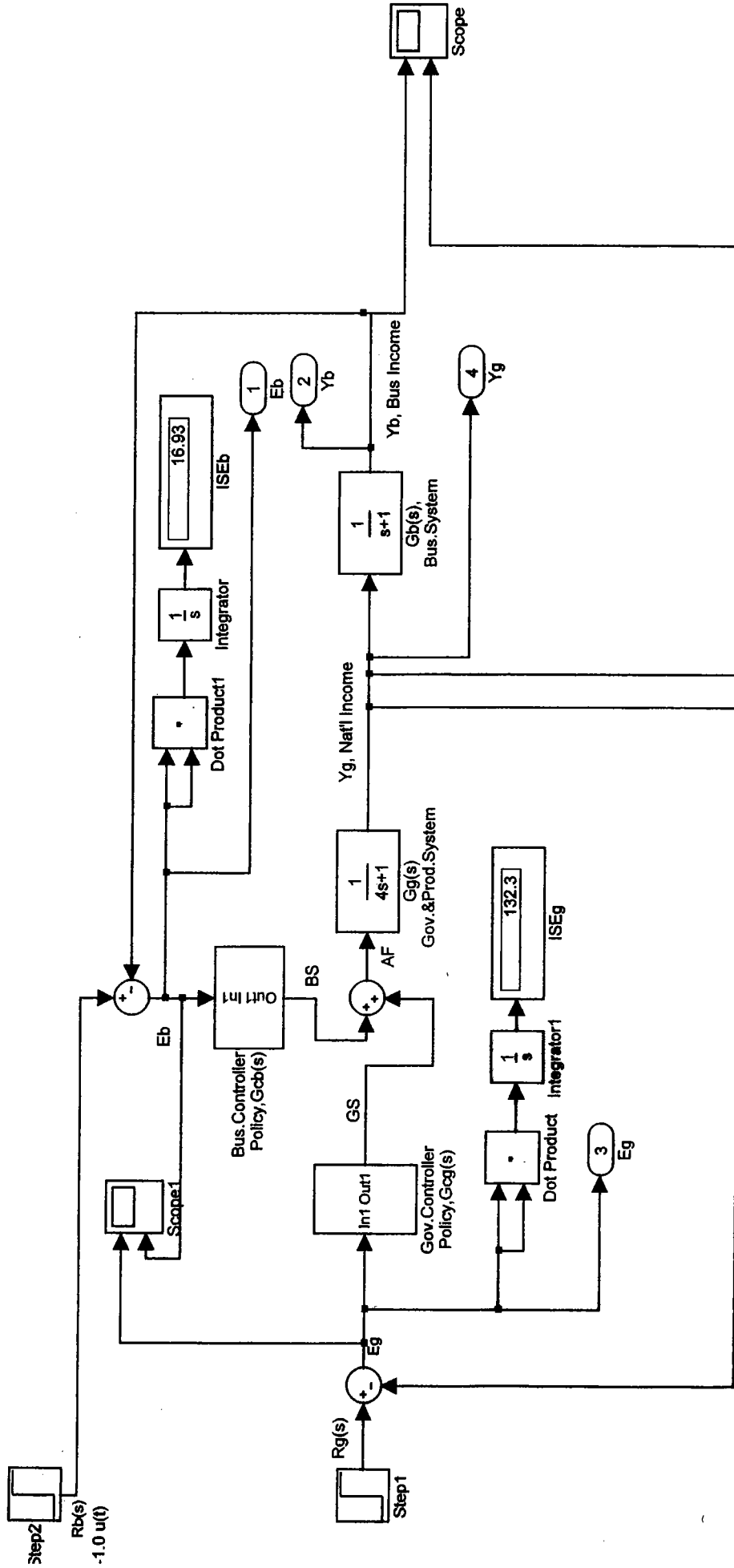
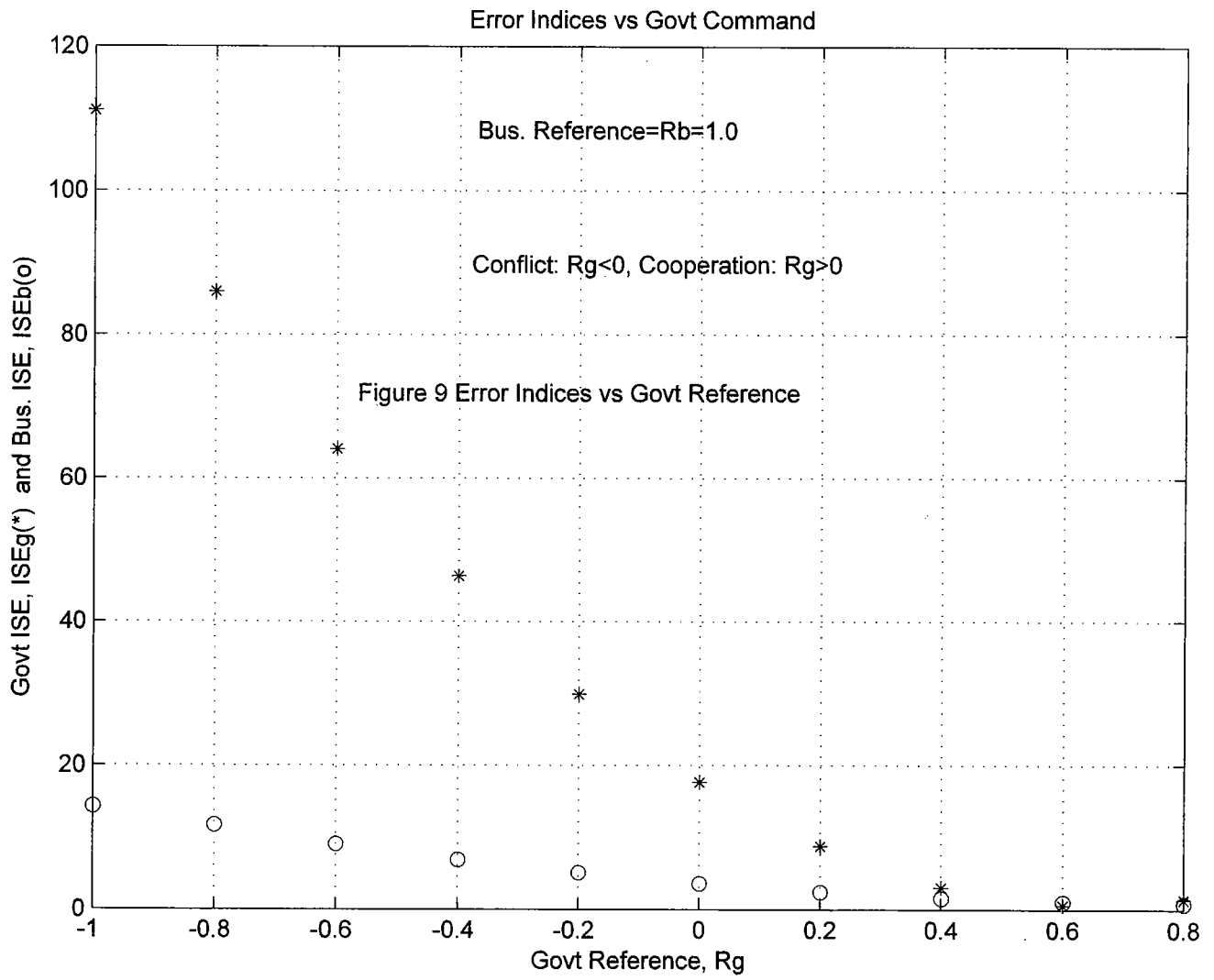
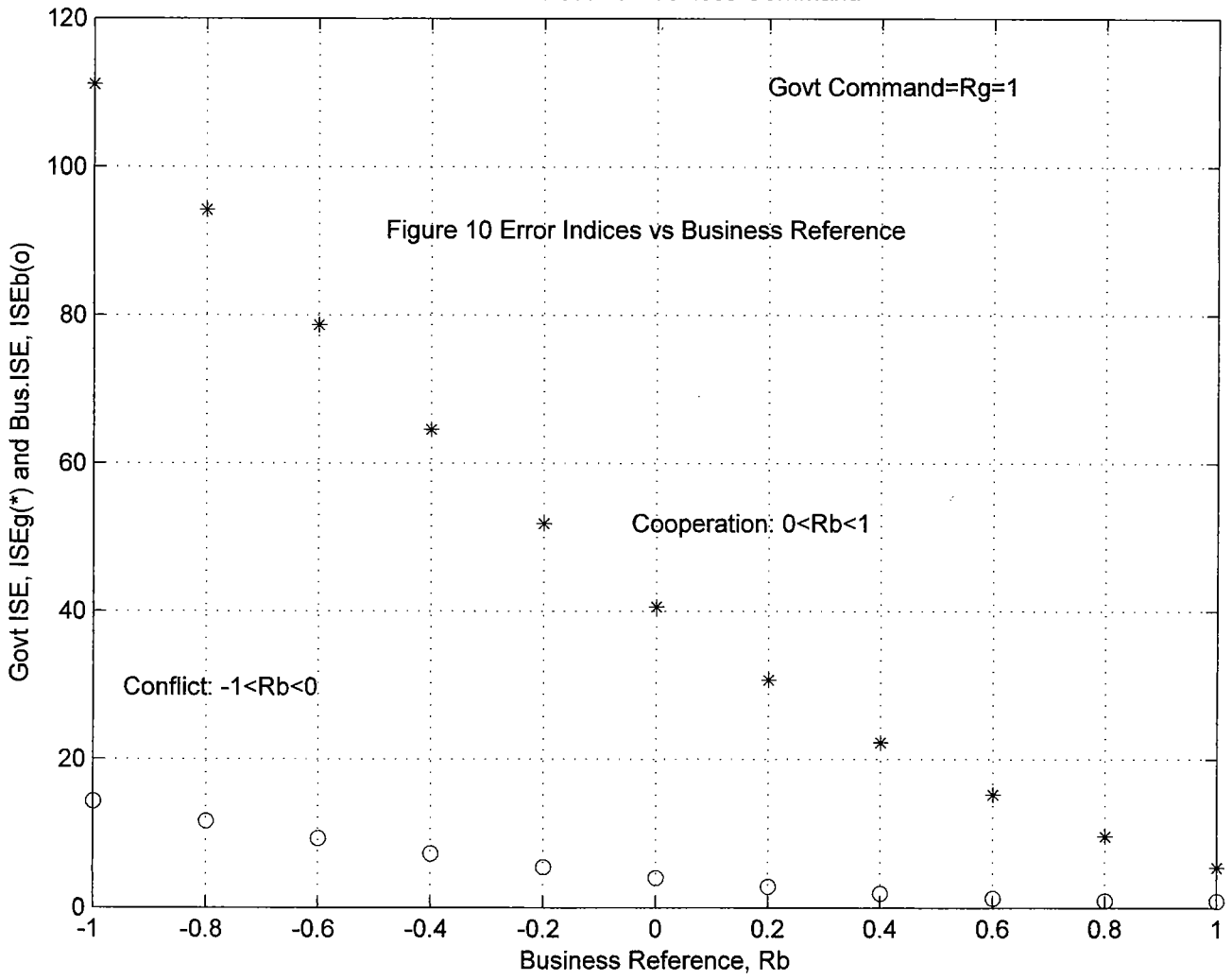

FIGURE 8 EXAMPLE OF CONFLICT THROUGH SIGNAL INJECTION

AF=Available Funds
 GS(s)=Gov't Spending
 BS= Bus. Spending



Error Indices vs Business Command



The National Economy as an Example of Control Under Conflict/Cooperation- A Simulation Approach

Robert L. Drake, Ph.D., P.E.
Department of Electrical and Computer Engineering
Christian Brothers University
Memphis, Tennessee
rdrake@cbu.edu

BACKGROUND

The work reported here is the result of teaching a course entitled ECE 488 Modeling and Simulation in Engineering Problems. This course is offered to students in both engineering and non-engineering. All students are required to simulate several dynamic systems during the semester at least one of which must be socio-political-economic (SPE) in nature. As instructor of the course, the writer chose the initial model of the national economy as an example of SPE systems to present to the class. This model was taken from reference [1] initially, and then as discussion progressed “refinements” were added. One of these refinements were reported in an earlier paper [2], where additional work suggested includes that of possible conflicts between the goals of government and the goals of business. The work reported here is the first attempt of the writer to approach that problem.

MODEL

The model hypothesized in this work is shown in the block diagram of Figure 1. Although inspired by the model suggested in reference [1], the model differs in several respects, among which are the inclusion of business investment as a separate input of the two-input system, identification of separate decision-making (controllers) for government and business, identification of different performance indices for government and business, and inclusion of two distinct outputs from the system. The inputs to the system are shown as business reference input (R_b) and the government reference input (R_g). The outputs from the system are shown as the national income level (Y_g) and the business income level (Y_b).

Figure 2 shows the identification of two performance indices chosen in this study. The performance index for government is based on the error, or difference, between the desired change in national income level and the measured change, E_g . In this case the integral squared value of this error is taken as the performance index. For business the error, or difference, is E_b as measured by the desired change in business income and the actual value. Again, the integral squared value of this error is used as the performance index.

Figure 3 shows the proportional plus integral (PI) controller chosen for the government controller. The controller constants were chosen to provide critical damping for the isolated government system. The government system is defined as isolated when the business input is set to zero (command for no change) and the business spending signal (BS) is set to zero. The simulation of the isolated government loop is shown in Figure 5 along with the indicated integral square error (ISE_g) of 6.681 for the unit step response which can be checked with theory for this particular index of performance. Figure 4 shows the PI controller chosen for the isolated business loop and Figure 6 shows the simulation result for this case where the ISE_b is 2.5 which also is checked by application of theory.

In Figure 1 the system representing government and production operations is shown with time constant of 4 time units and “dc” gain of 1. The system representing business operations is shown with time constant of 1 time unit and gain of 1.

DEFINITION OF CONFLICT AND COOPERATION

In Figure 2 the goal of government is to reduce as much as possible the performance index defined in this case as the integral square of the error signal E_g shown as ISE_g. The goal of business is to reduce ISE_b as much as possible. In the model shown, there is coupling between the government loop and the business loop with the result that propagation of signals in one loop affects the operation of the second loop. In the context of this work, conflict is defined to exist if the effect of the first loop upon the second loop is such that the performance index of the second is worsened, or increased in this case where the goal is to decrease the ISE. Similarly, cooperation is defined to exist if the coupling effect improves the performance index.

Simulation makes obvious that conflict and cooperation can exist because of signal injection or because of system modification without signal injection, or both. In Figure 7 no signal is injected by the business system, but because of the presence of the business feedback loop the government performance index ISE_g is increased by a factor of (34.81/6.68), or 5.2 to 1. By the definition above, conflict exists. On the other hand, in Figure 8 signal injection at the business reference input R_b along with the feedback in the business loop results in ISE_g increase by a factor of (132.3/6.68), or 19.8 to 1. Conflict from signal injection in this case results from the opposite signs in the reference input to the government loop and reference input to the business loop.

ADDITIONAL SIMULATION RESULTS

Additional simulation results are shown in Figures 9 and 10. Figure 9 shows the variation of the performance indices ISE_g and ISE_b with government reference R_g with business reference R_b held constant at unity. By the definitions above for cooperation and conflict,

cooperation increases as R_g varies from 0 to 1 and conflict increases as R_g varies from 0 to -1. There is a rapid increase in the error indices as the conflict increases and a rapid decrease in the error indices as the cooperation increases. Figure 10 shows the variation of the error indices as a function of the business reference R_b with the government reference held constant at unity. Again, there is a rapid increase in error indices as conflict increases and a rapid decrease in error indices as cooperation increases.

SUMMARY AND CONCLUSIONS

(1) Conflict may be defined by the actions of one participant, say business, tending to increase the performance index being minimized by the second participant, say government. Cooperation may be defined as existing when the actions of one of the participants tends to reduce the performance index being minimized by the second participant.

(2) Cooperation/conflict may result from either signal injection or from system modification, or both.

FUTURE WORK

(1) The effects of consumers should be added to the model. With three participants present, the possibility of joint cooperation/conflict arises. Include the effect of foreign investment.

(2) Practical data and reasonable scaling limits should be added. This probably requires participation of personnel with backgrounds in business and economics.

(3) Re-phrase the problem in terms of state variables and vector-matrix operations. Use modern control theory to re-design the controllers. Consider the possibility of decoupling output except from one input.

FINAL COMMENTS

(1) This is a work in progress.

(2) Results and conclusions, although believed to be original, are preliminary and should be considered as such.

REFERENCES

- [1] S.M. Shinnars, Modern Control Theory and Application, Reading, MA, Addison-Wesley, 1972.
- [2] R.L. Drake, "Do Checks and Balances Contribute to Cycles in the Economy?", MAESC 2003, Christian Brothers University, Memphis, TN, May 15, 2003.

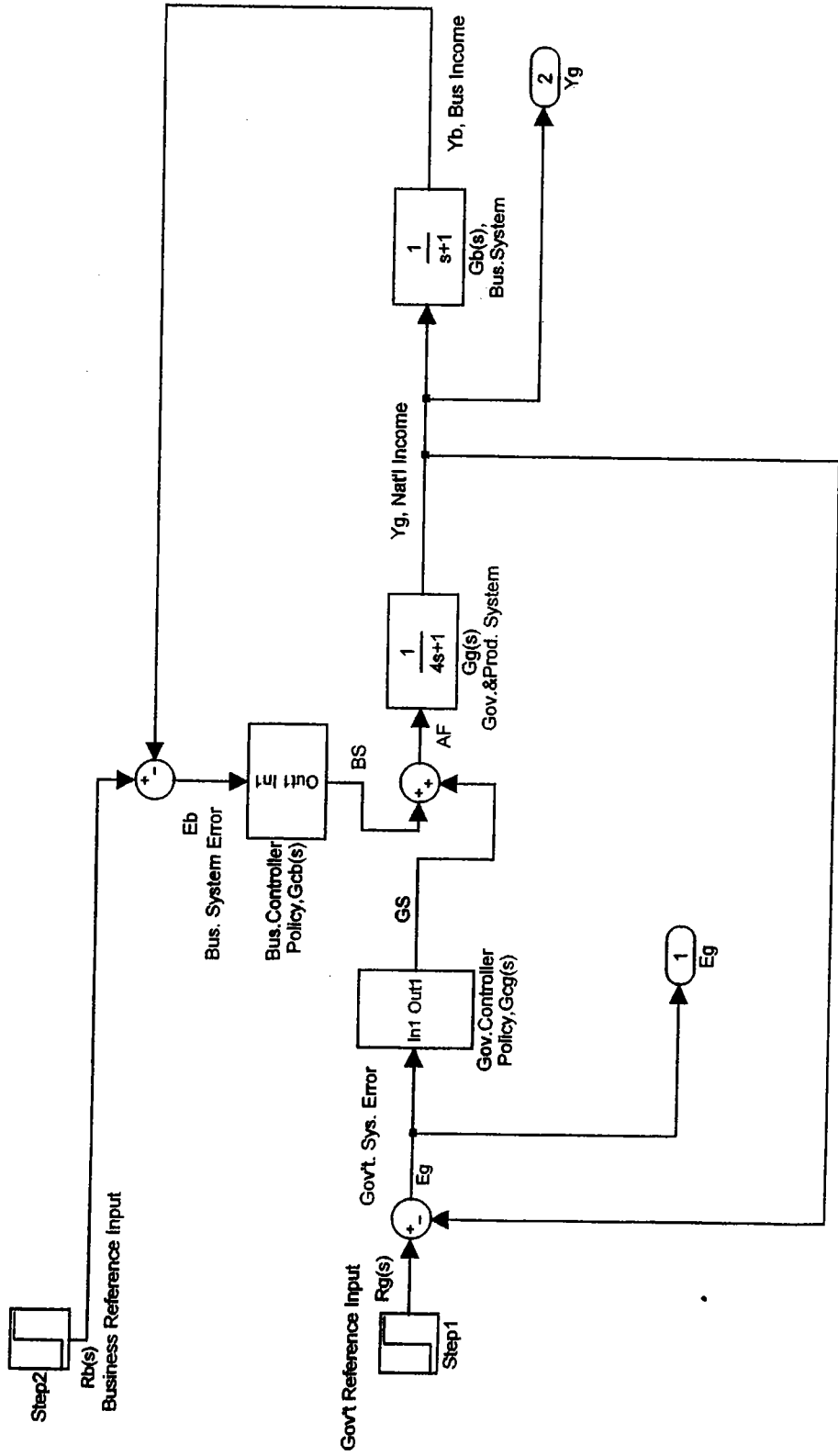

FIGURE 1 BLOCK DIAGRAM

AF=Available Funds
 GS(s)=Gov't Spending
 BS= Bus. Spending

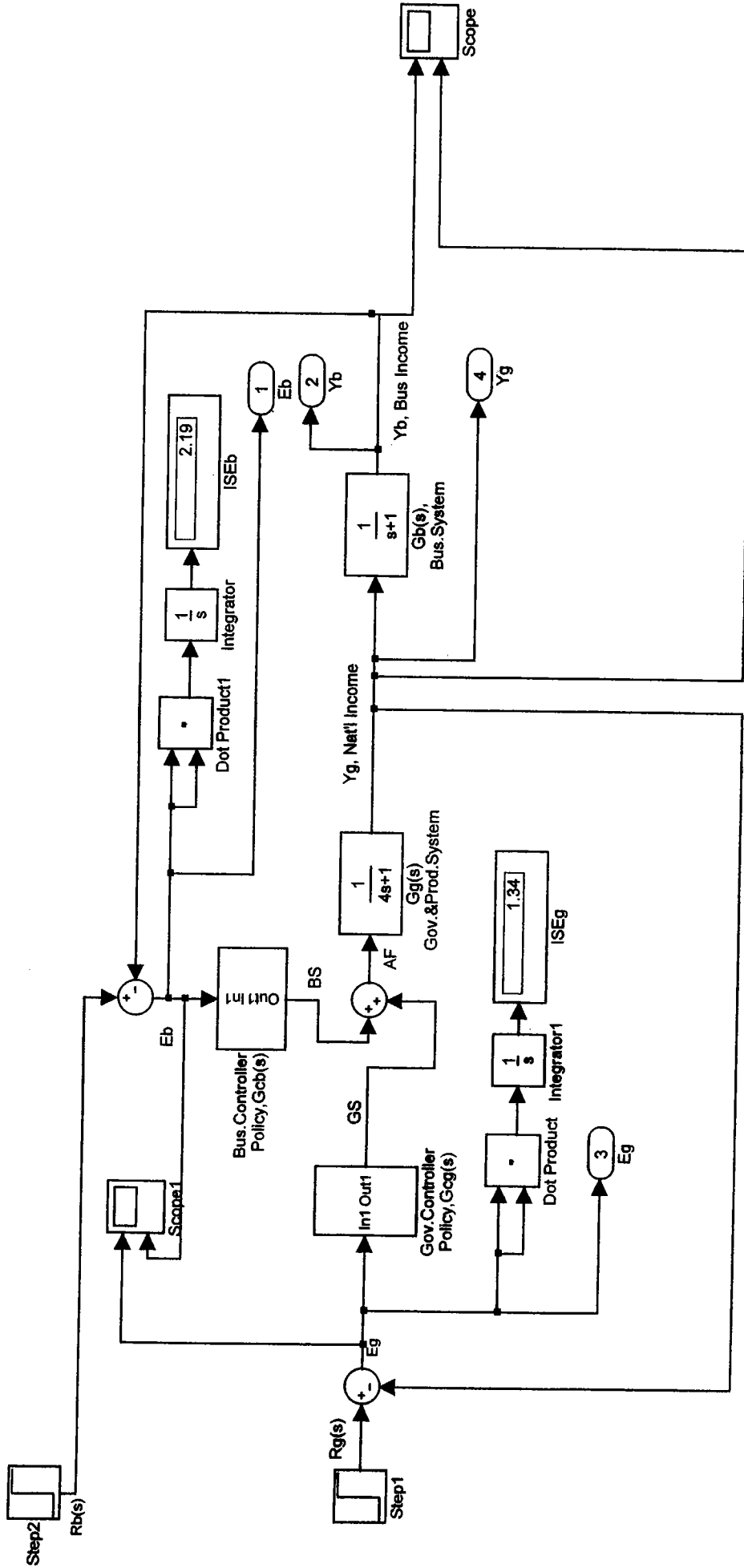

FIGURE 2 BLOCK DIAGRAM with VIRTUAL INSTRUMENTATION and COMPUTATION

AF=Available Funds
 GS(s)=Gov't Spending
 BS= Bus. Spending

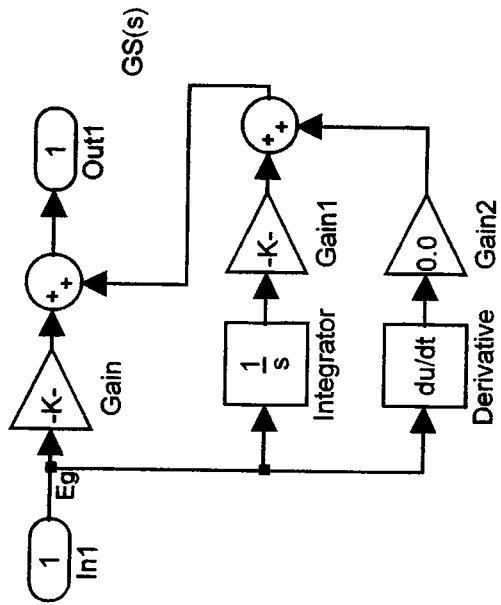

FIGURE 3 GOVERNMENT PI CONTROLLER

$K_p=0.1716$

$K_i=0.0858$

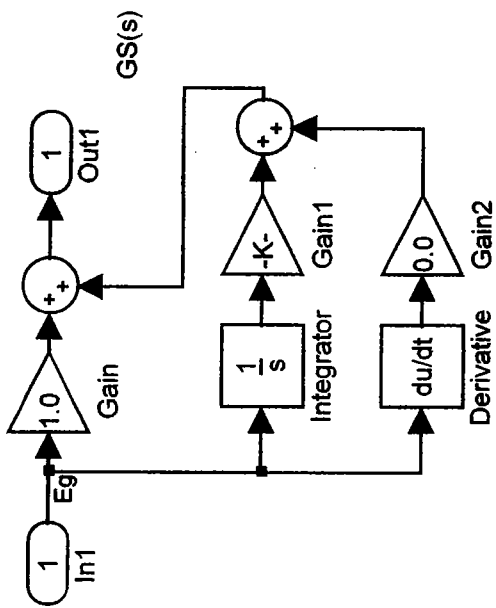

FIGURE 4 BUSINESS PI CONTROLLER

$Kp=1.0$
 $Ki=0.25$

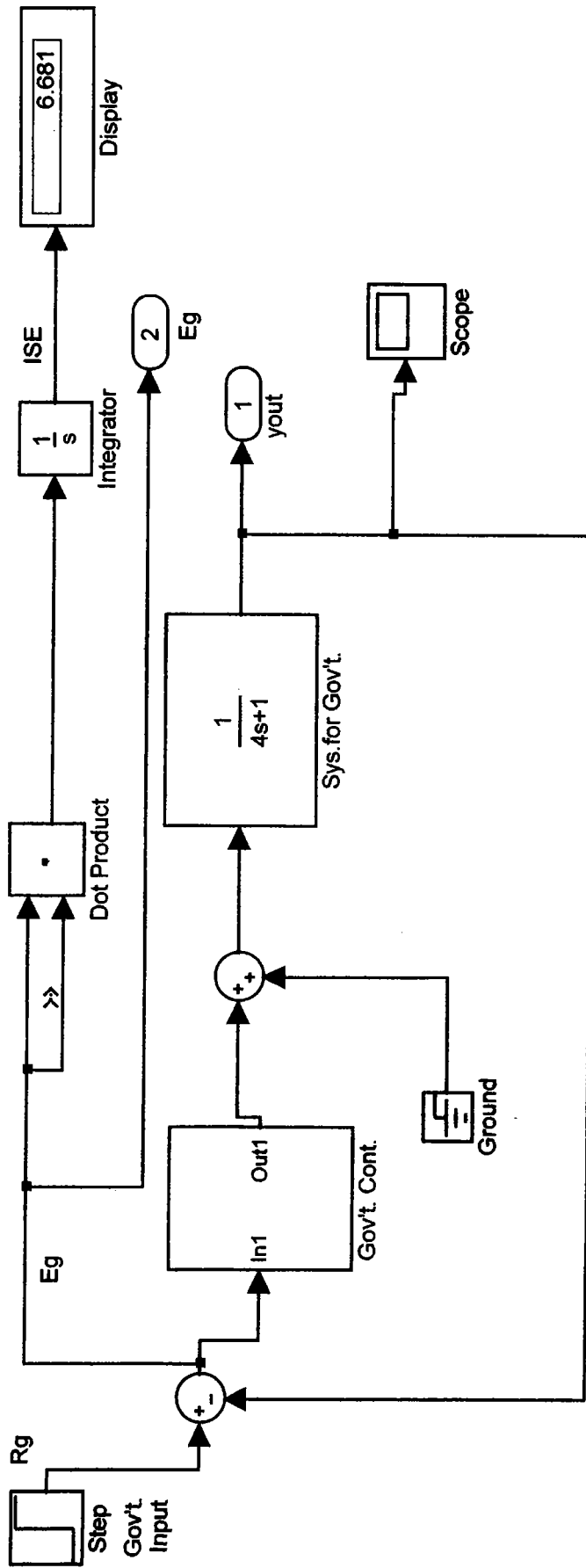

FIGURE 5 ISOLATED GOVERNMENT LOOP

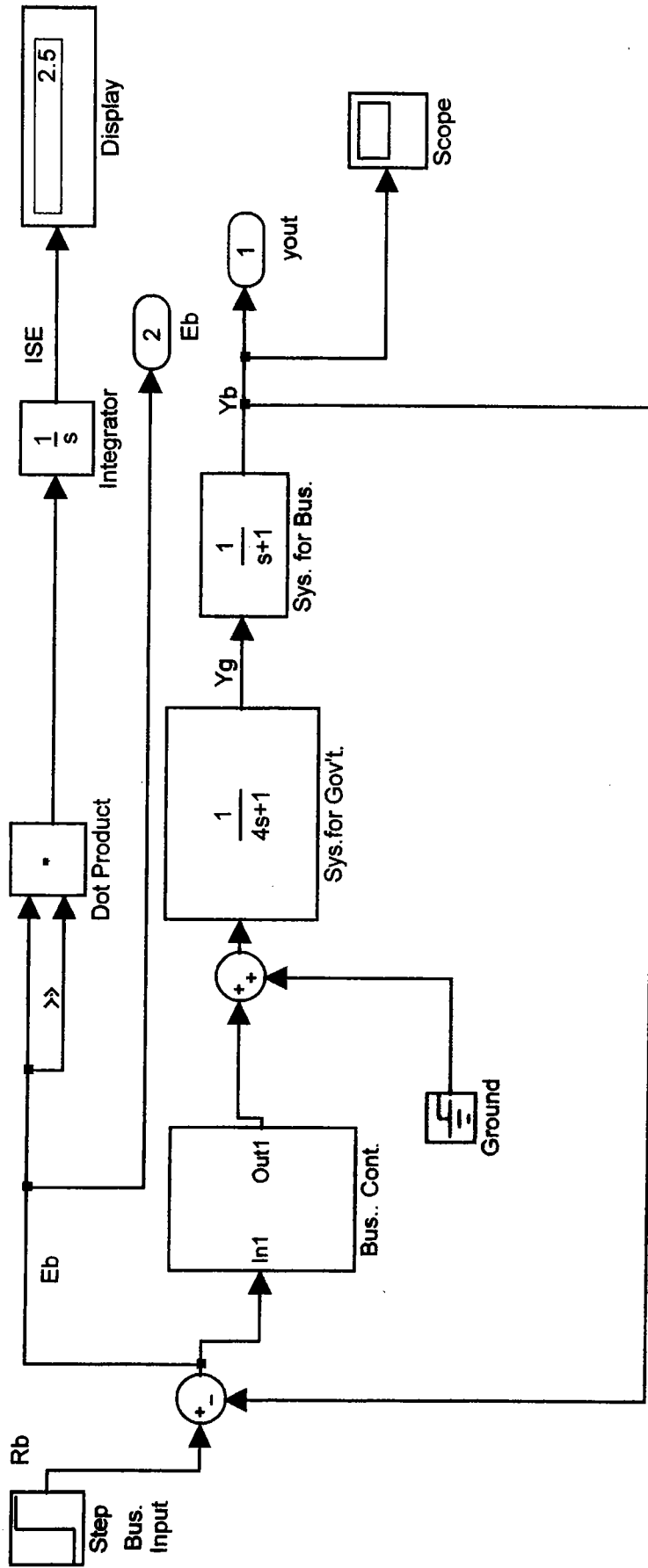

FIGURE 6 ISOLATED BUSINESS LOOP

Step2

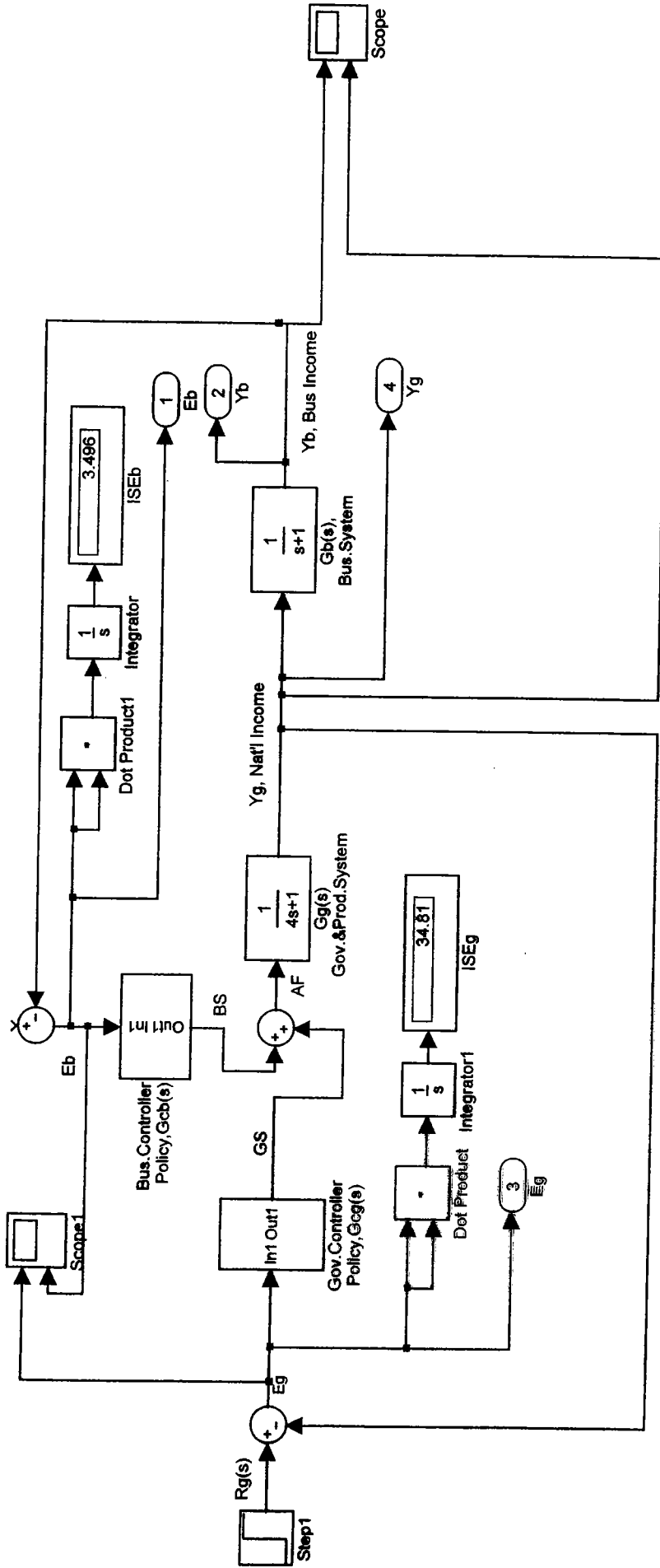
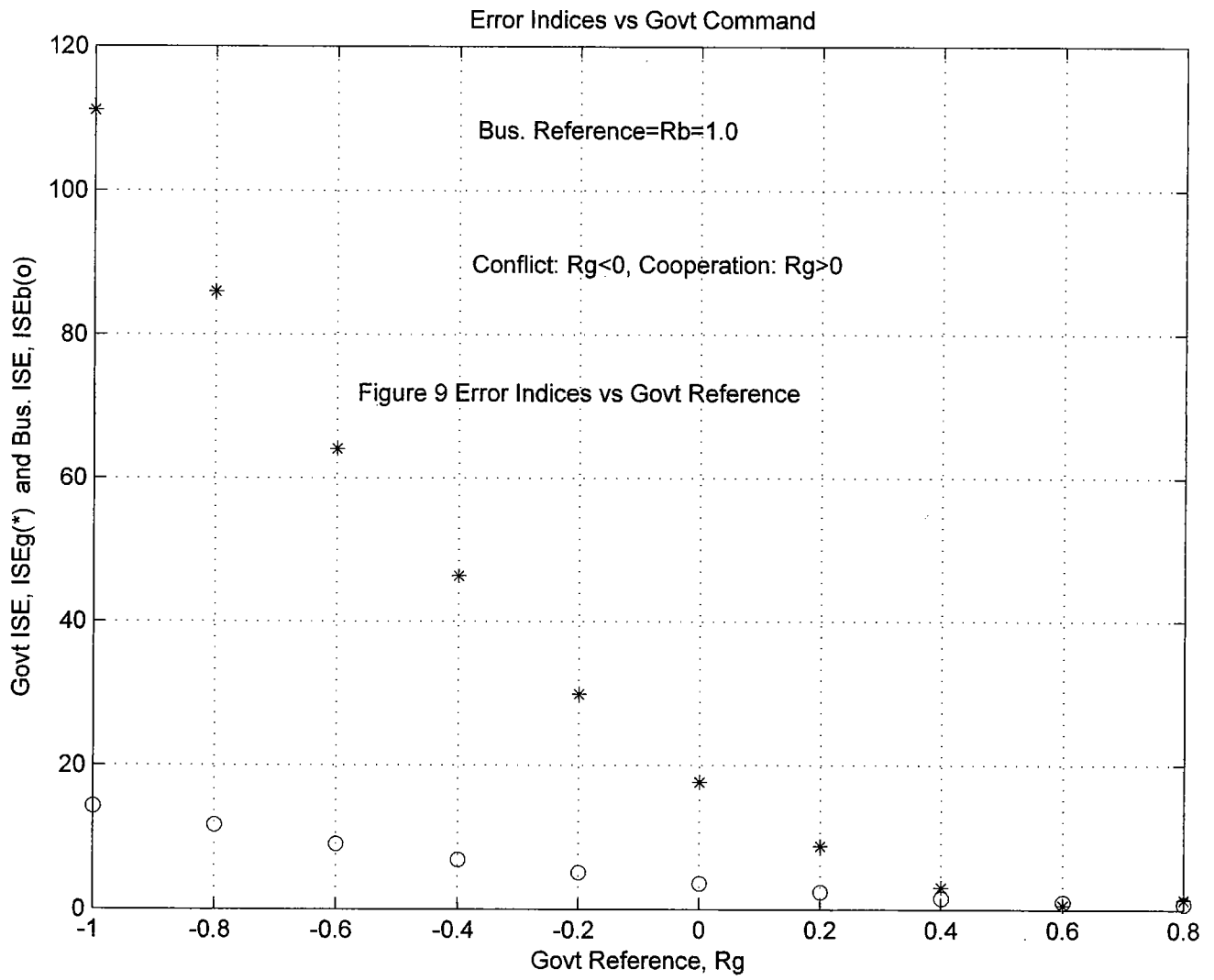

FIGURE 7 ZERO SIGNAL INJECTION FROM BUSINESS WITH SYSTEM MODIFICATION

AF=Available Funds

GS(s)=Gov't Spending

BS= Bus. Spending



Error Indices vs Business Command

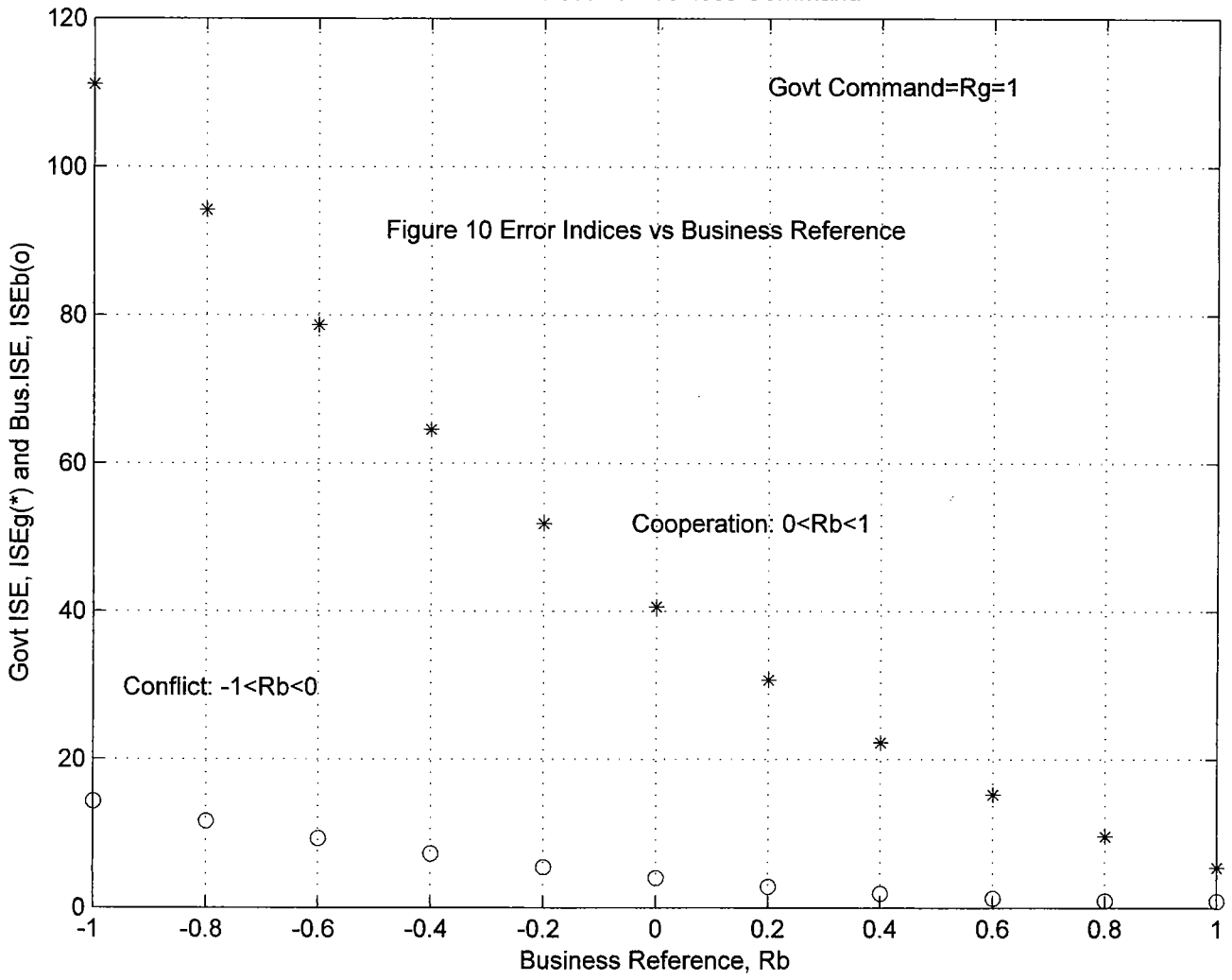

The National Economy as an Example of Control Under Conflict/Cooperation- A Simulation Approach

Robert L. Drake, Ph.D., P.E.
Department of Electrical and Computer Engineering
Christian Brothers University
Memphis, Tennessee
rdrake@cbu.edu

BACKGROUND

The work reported here is the result of teaching a course entitled ECE 488 Modeling and Simulation in Engineering Problems. This course is offered to students in both engineering and non-engineering. All students are required to simulate several dynamic systems during the semester at least one of which must be socio-political-economic (SPE) in nature. As instructor of the course, the writer chose the initial model of the national economy as an example of SPE systems to present to the class. This model was taken from reference [1] initially, and then as discussion progressed “refinements” were added. One of these refinements were reported in an earlier paper [2], where additional work suggested includes that of possible conflicts between the goals of government and the goals of business. The work reported here is the first attempt of the writer to approach that problem.

MODEL

The model hypothesized in this work is shown in the block diagram of Figure 1. Although inspired by the model suggested in reference [1], the model differs in several respects, among which are the inclusion of business investment as a separate input of the two-input system, identification of separate decision-making (controllers) for government and business, identification of different performance indices for government and business, and inclusion of two distinct outputs from the system. The inputs to the system are shown as business reference input (R_b) and the government reference input (R_g). The outputs from the system are shown as the national income level (Y_g) and the business income level (Y_b).

Figure 2 shows the identification of two performance indices chosen in this study. The performance index for government is based on the error, or difference, between the desired change in national income level and the measured change, E_g . In this case the integral squared value of this error is taken as the performance index. For business the error, or difference, is E_b as measured by the desired change in business income and the actual value. Again, the integral squared value of this error is used as the performance index.

Figure 3 shows the proportional plus integral (PI) controller chosen for the government controller. The controller constants were chosen to provide critical damping for the isolated government system. The government system is defined as isolated when the business input is set to zero (command for no change) and the business spending signal (BS) is set to zero. The simulation of the isolated government loop is shown in Figure 5 along with the indicated integral square error (ISEg) of 6.681 for the unit step response which can be checked with theory for this particular index of performance. Figure 4 shows the PI controller chosen for the isolated business loop and Figure 6 shows the simulation result for this case where the ISEb is 2.5 which also is checked by application of theory.

In Figure 1 the system representing government and production operations is shown with time constant of 4 time units and “dc” gain of 1. The system representing business operations is shown with time constant of 1 time unit and gain of 1.

DEFINITION OF CONFLICT AND COOPERATION

In Figure 2 the goal of government is to reduce as much as possible the performance index defined in this case as the integral square of the error signal E_g shown as ISEg. The goal of business is to reduce ISEb as much as possible. In the model shown, there is coupling between the government loop and the business loop with the result that propagation of signals in one loop affects the operation of the second loop. In the context of this work, conflict is defined to exist if the effect of the first loop upon the second loop is such that the performance index of the second is worsened, or increased in this case where the goal is to decrease the ISE. Similarly, cooperation is defined to exist if the coupling effect improves the performance index.

Simulation makes obvious that conflict and cooperation can exist because of signal injection or because of system modification without signal injection, or both. In Figure 7 no signal is injected by the business system, but because of the presence of the business feedback loop the government performance index ISEg is increased by a factor of $(34.81/6.68)$, or 5.2 to 1. By the definition above, conflict exists. On the other hand, in Figure 8 signal injection at the business reference input R_b along with the feedback in the business loop results in ISEg increase by a factor of $(132.3/6.68)$, or 19.8 to 1. Conflict from signal injection in this case results from the opposite signs in the reference input to the government loop and reference input to the business loop.

ADDITIONAL SIMULATION RESULTS

Additional simulation results are shown in Figures 9 and 10. Figure 9 shows the variation of the performance indices ISEg and ISEb with government reference R_g with business reference R_b held constant at unity. By the definitions above for cooperation and conflict,

cooperation increases as R_g varies from 0 to 1 and conflict increases as R_g varies from 0 to -1. There is a rapid increase in the error indices as the conflict increases and a rapid decrease in the error indices as the cooperation increases. Figure 10 shows the variation of the error indices as a function of the business reference R_b with the government reference held constant at unity. Again, there is a rapid increase in error indices as conflict increases and a rapid decrease in error indices as cooperation increases.

SUMMARY AND CONCLUSIONS

(1) Conflict may be defined by the actions of one participant, say business, tending to increase the performance index being minimized by the second participant, say government. Cooperation may be defined as existing when the actions of one of the participants tends to reduce the performance index being minimized by the second participant.

(2) Cooperation/conflict may result from either signal injection or from system modification, or both.

FUTURE WORK

(1) The effects of consumers should be added to the model. With three participants present, the possibility of joint cooperation/conflict arises. Include the effect of foreign investment.

(2) Practical data and reasonable scaling limits should be added. This probably requires participation of personnel with backgrounds in business and economics.

(3) Re-phrase the problem in terms of state variables and vector-matrix operations. Use modern control theory to re-design the controllers. Consider the possibility of decoupling output except from one input.

FINAL COMMENTS

(1) This is a work in progress.

(2) Results and conclusions, although believed to be original, are preliminary and should be considered as such.

REFERENCES

- [1] S.M. Shinnars, Modern Control Theory and Application, Reading, MA, Addison-Wesley, 1972.
- [2] R.L. Drake, "Do Checks and Balances Contribute to Cycles in the Economy?", MAESC 2003, Christian Brothers University, Memphis, TN, May 15, 2003.

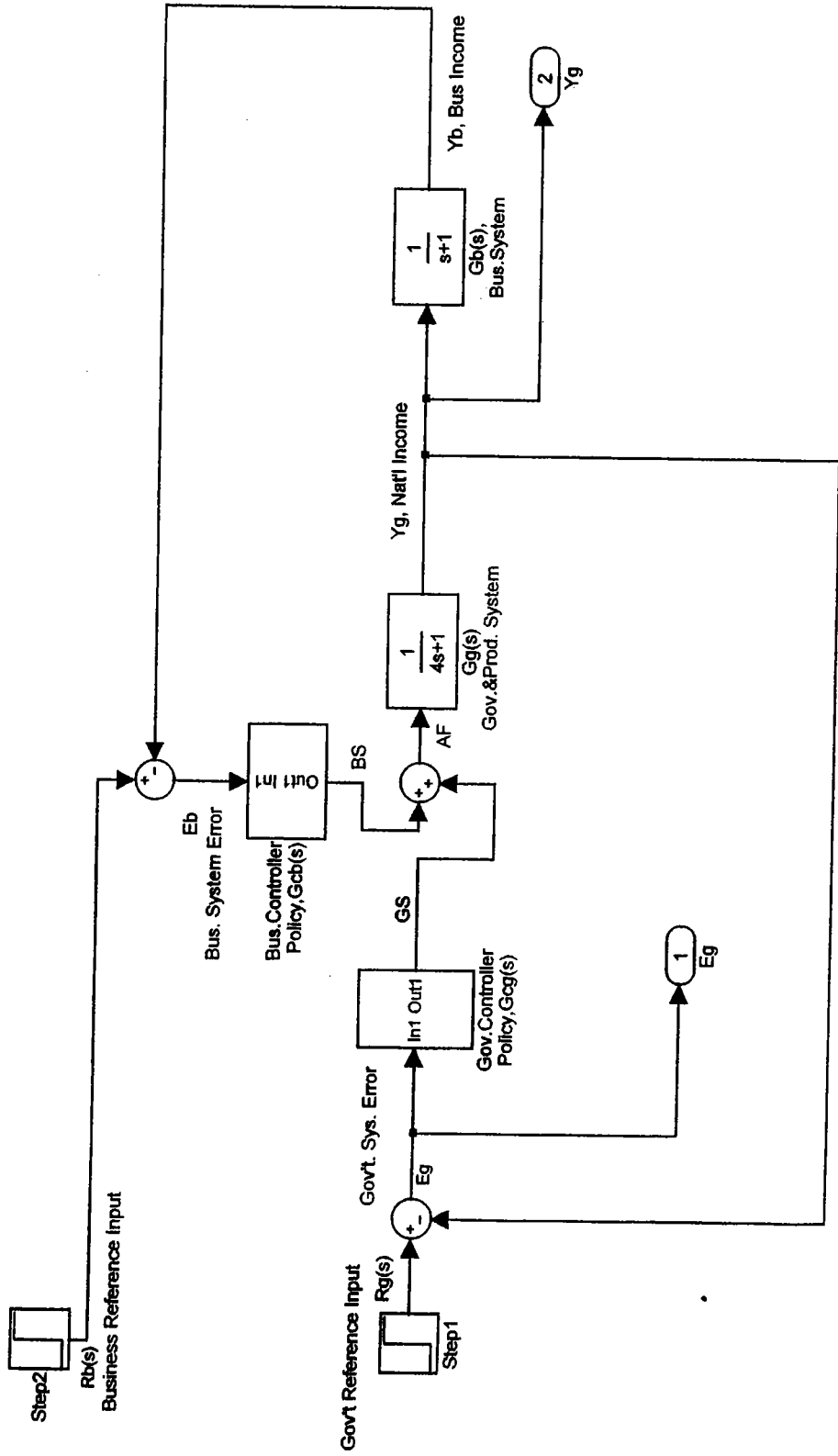

FIGURE 1 BLOCK DIAGRAM

AF=Available Funds
 GS(s)=Gov't Spending
 BS= Bus. Spending

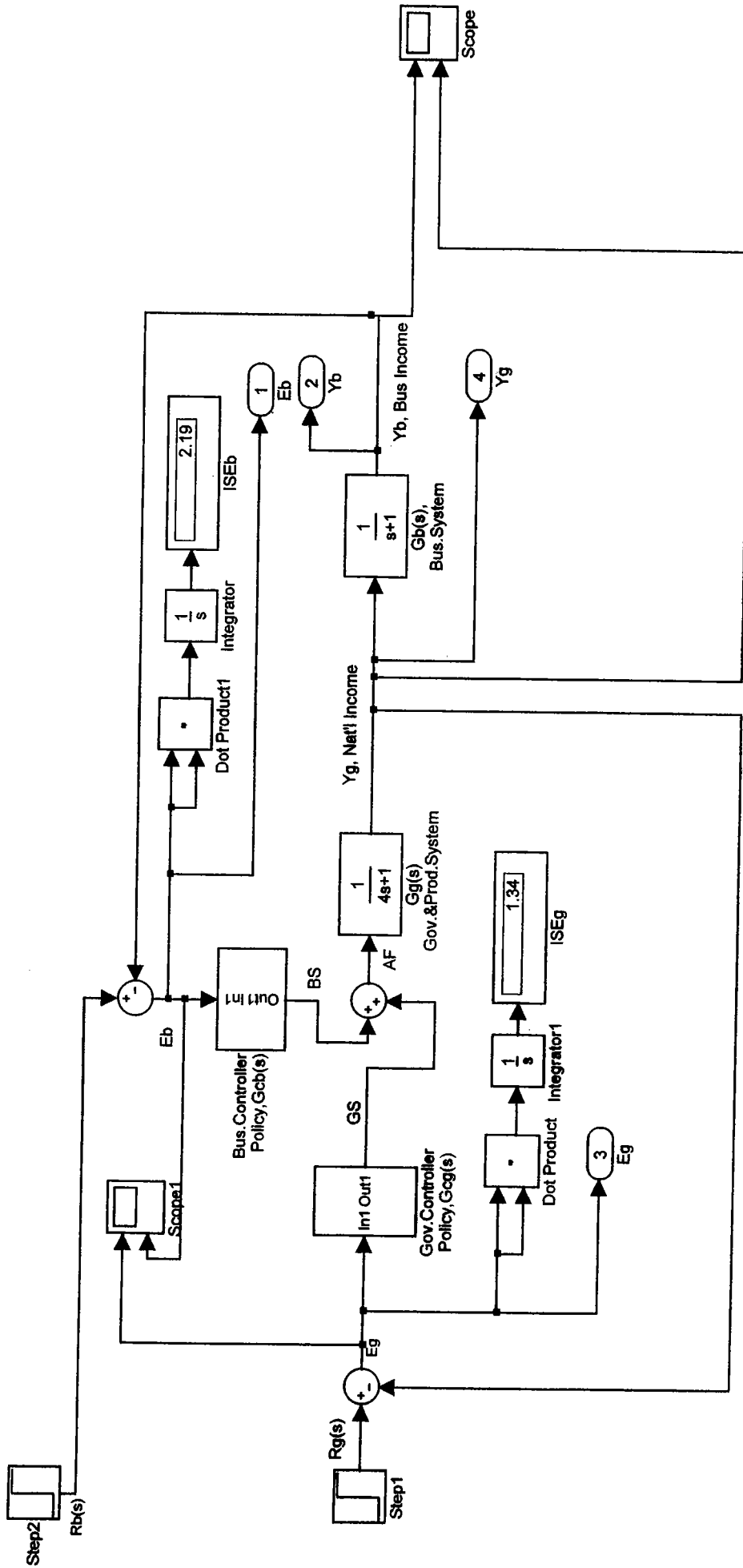

FIGURE 2 BLOCK DIAGRAM with VIRTUAL INSTRUMENTATION and COMPUTATION

AF=Available Funds
 GS(s)=Gov't Spending
 BS= Bus. Spending

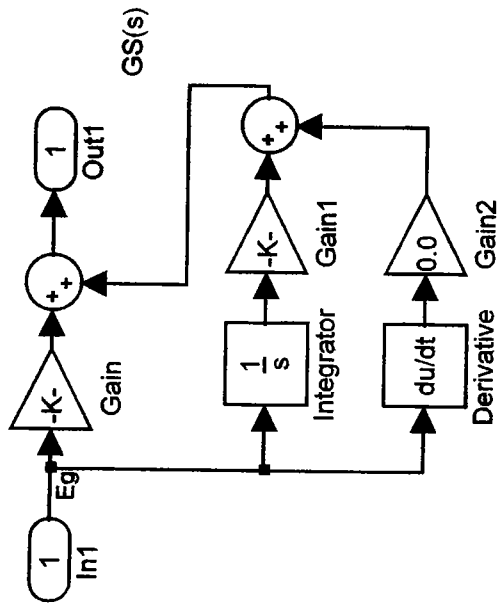

FIGURE 3 GOVERNMENT PI CONTROLLER

$K_p=0.1716$

$K_i=0.0858$

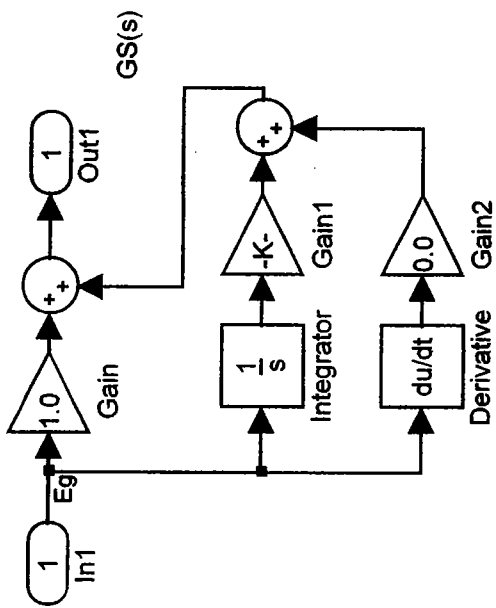

FIGURE 4 BUSINESS PI CONTROLLER

$K_p=1.0$
 $K_i=0.25$

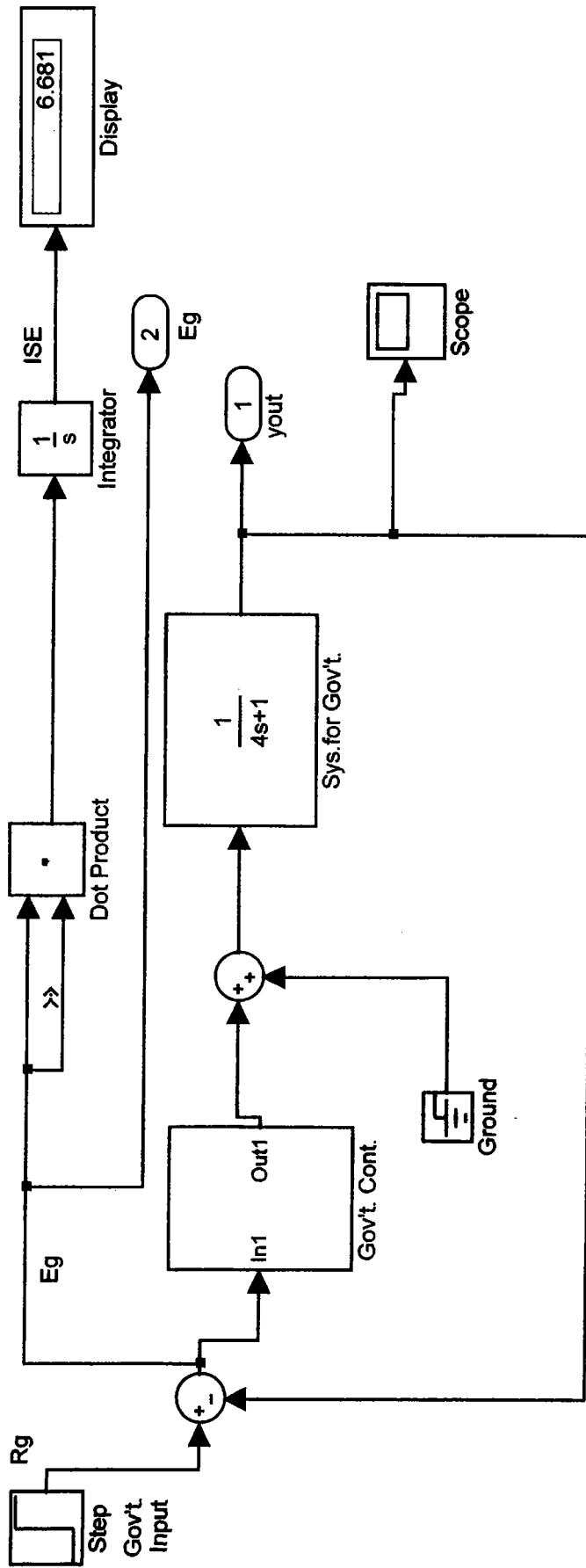

FIGURE 5 ISOLATED GOVERNMENT LOOP

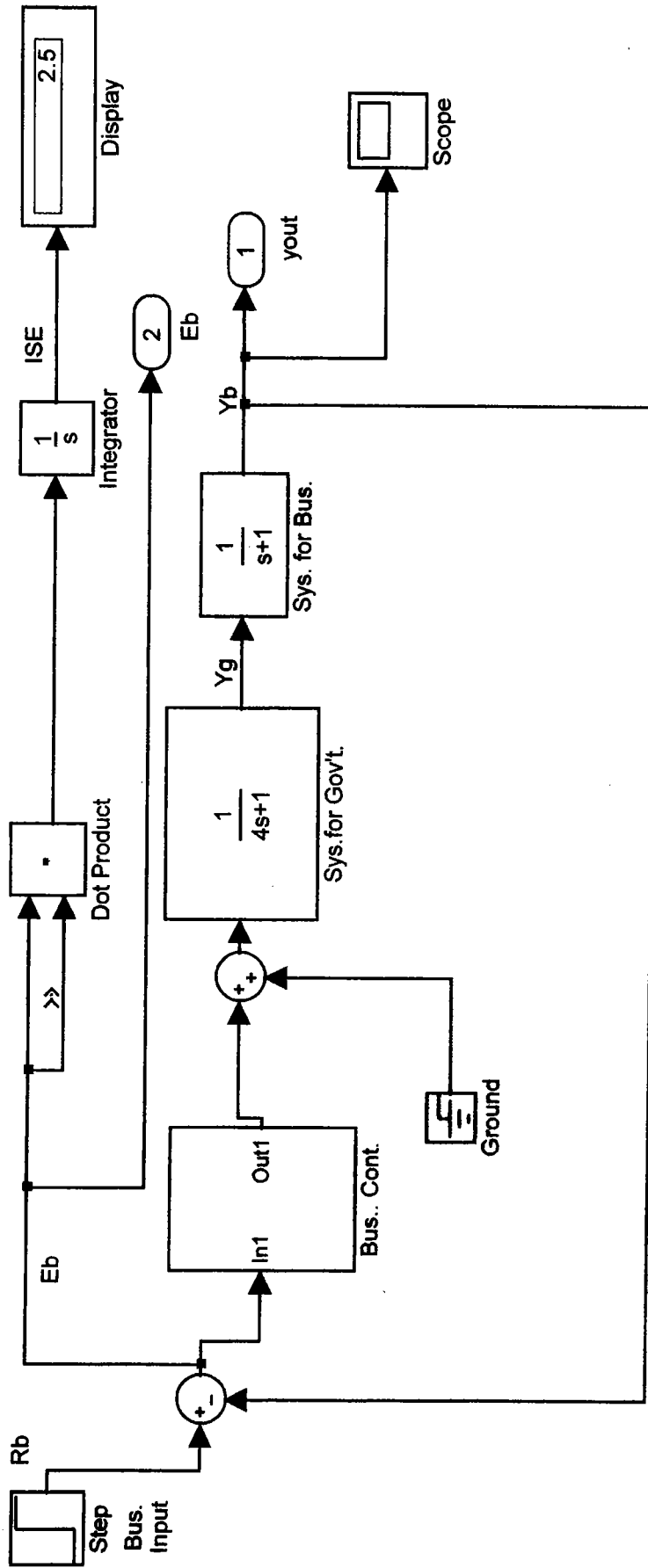

FIGURE 6 ISOLATED BUSINESS LOOP

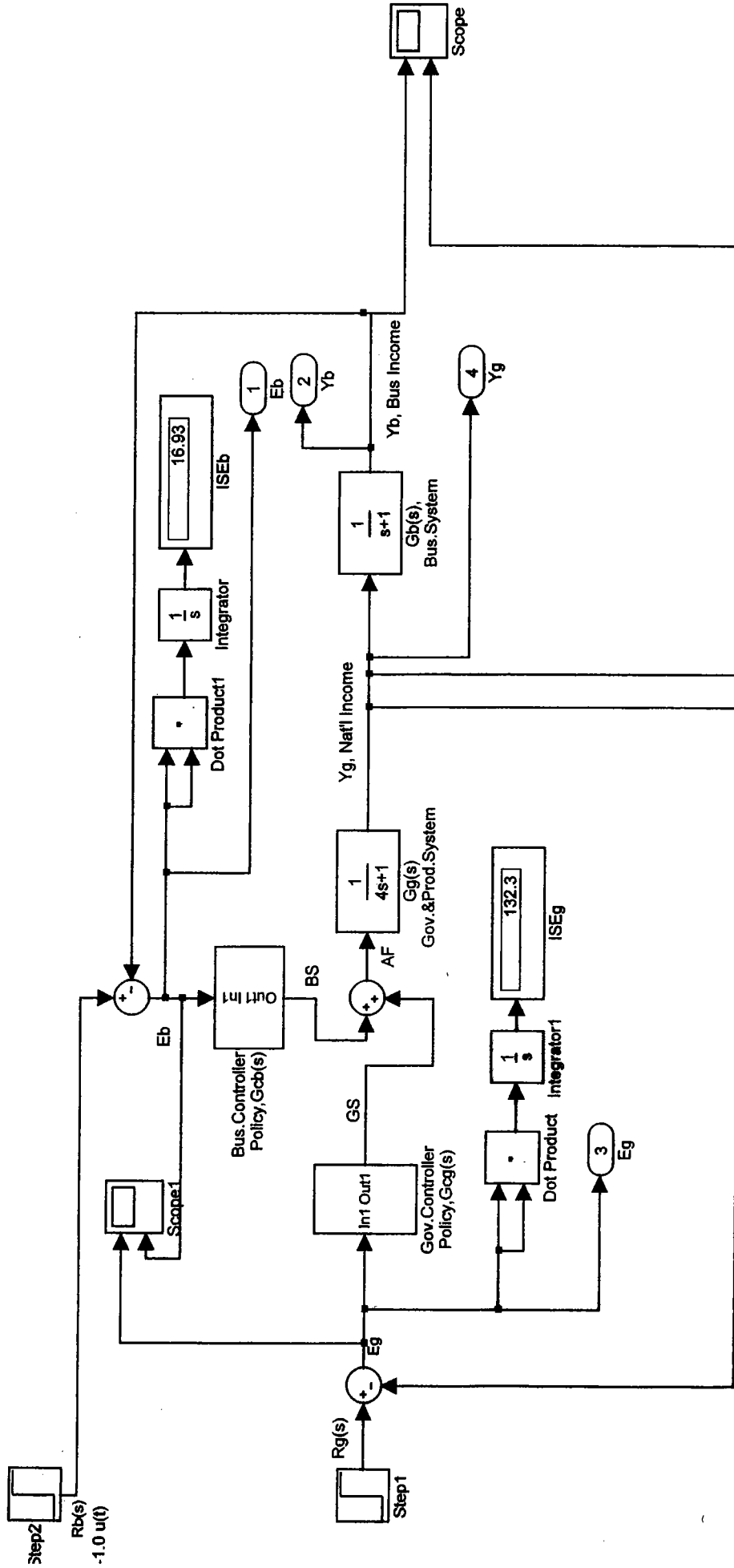
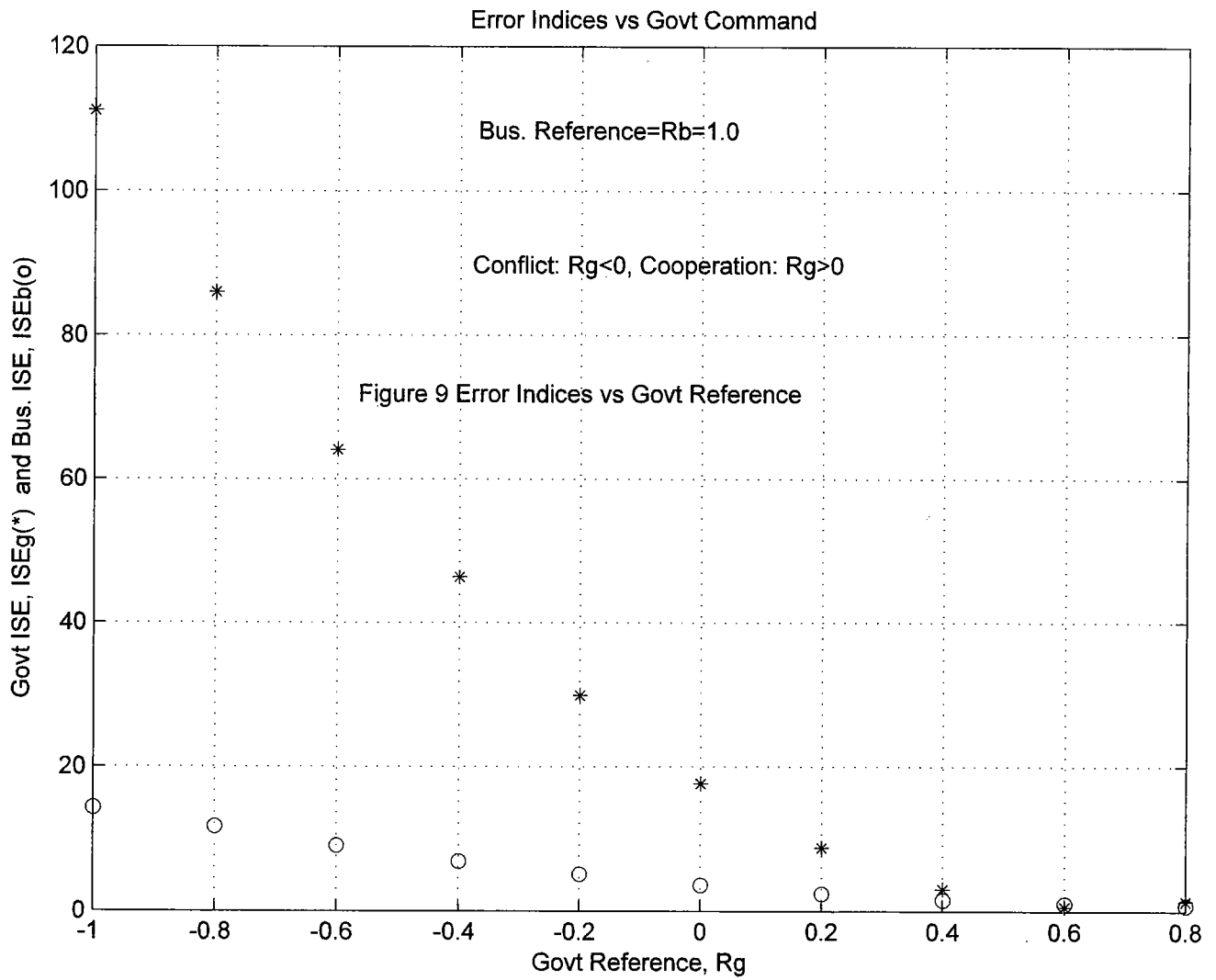

FIGURE 8 EXAMPLE OF CONFLICT THROUGH SIGNAL INJECTION

AF=Available Funds

GS(s)=Gov't
Spending

BS= Bus. Spending



Error Indices vs Business Command

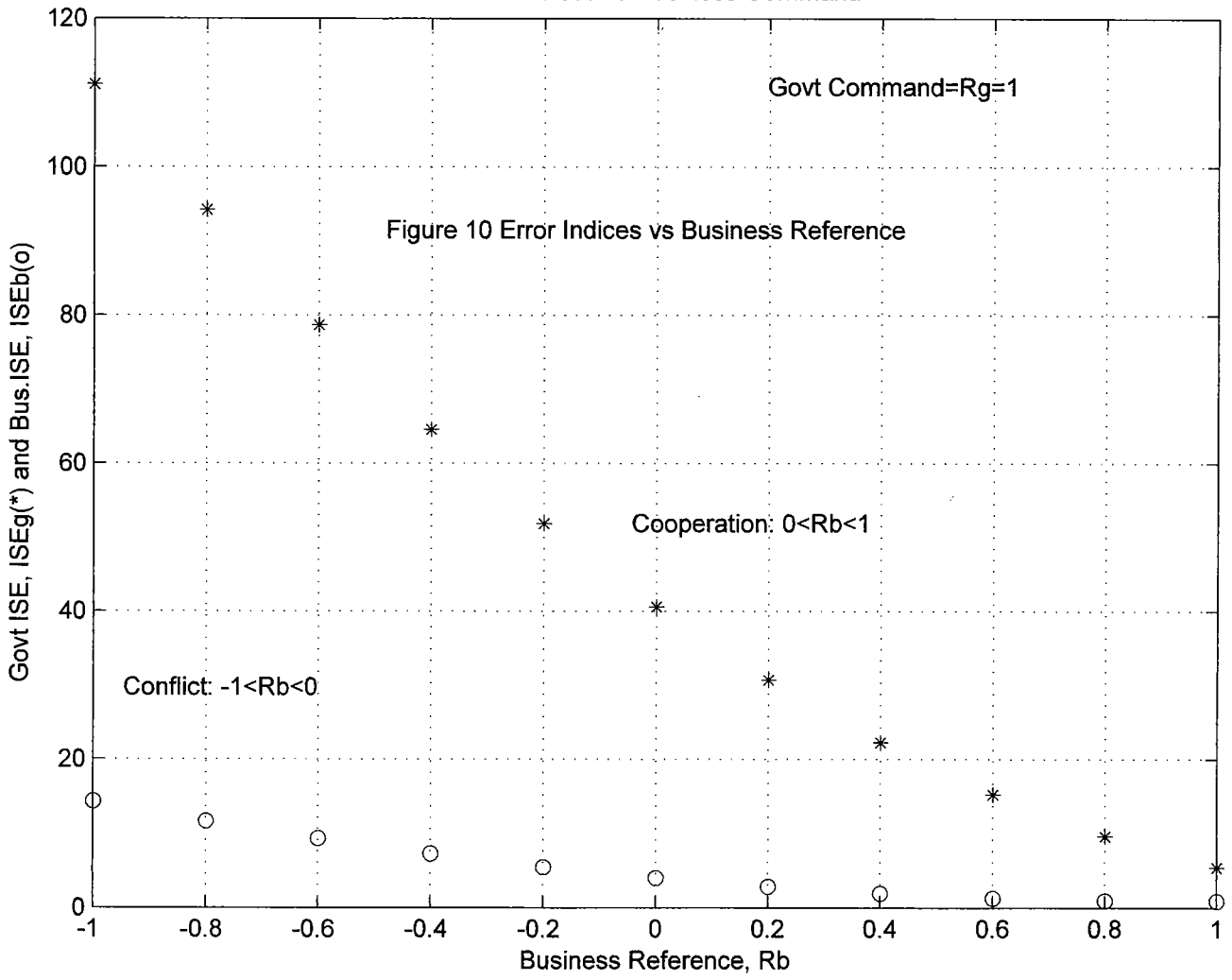

The National Economy as an Example of Control Under Conflict/Cooperation- A Simulation Approach

Robert L. Drake, Ph.D., P.E.
Department of Electrical and Computer Engineering
Christian Brothers University
Memphis, Tennessee
rdrake@cbu.edu

BACKGROUND

The work reported here is the result of teaching a course entitled ECE 488 Modeling and Simulation in Engineering Problems. This course is offered to students in both engineering and non-engineering. All students are required to simulate several dynamic systems during the semester at least one of which must be socio-political-economic (SPE) in nature. As instructor of the course, the writer chose the initial model of the national economy as an example of SPE systems to present to the class. This model was taken from reference [1] initially, and then as discussion progressed “refinements” were added. One of these refinements were reported in an earlier paper [2], where additional work suggested includes that of possible conflicts between the goals of government and the goals of business. The work reported here is the first attempt of the writer to approach that problem.

MODEL

The model hypothesized in this work is shown in the block diagram of Figure 1. Although inspired by the model suggested in reference [1], the model differs in several respects, among which are the inclusion of business investment as a separate input of the two-input system, identification of separate decision-making (controllers) for government and business, identification of different performance indices for government and business, and inclusion of two distinct outputs from the system. The inputs to the system are shown as business reference input (R_b) and the government reference input (R_g). The outputs from the system are shown as the national income level (Y_g) and the business income level (Y_b).

Figure 2 shows the identification of two performance indices chosen in this study. The performance index for government is based on the error, or difference, between the desired change in national income level and the measured change, E_g . In this case the integral squared value of this error is taken as the performance index. For business the error, or difference, is E_b as measured by the desired change in business income and the actual value. Again, the integral squared value of this error is used as the performance index.

Figure 3 shows the proportional plus integral (PI) controller chosen for the government controller. The controller constants were chosen to provide critical damping for the isolated government system. The government system is defined as isolated when the business input is set to zero (command for no change) and the business spending signal (BS) is set to zero. The simulation of the isolated government loop is shown in Figure 5 along with the indicated integral square error (ISEg) of 6.681 for the unit step response which can be checked with theory for this particular index of performance. Figure 4 shows the PI controller chosen for the isolated business loop and Figure 6 shows the simulation result for this case where the ISEb is 2.5 which also is checked by application of theory.

In Figure 1 the system representing government and production operations is shown with time constant of 4 time units and “dc” gain of 1. The system representing business operations is shown with time constant of 1 time unit and gain of 1.

DEFINITION OF CONFLICT AND COOPERATION

In Figure 2 the goal of government is to reduce as much as possible the performance index defined in this case as the integral square of the error signal E_g shown as ISEg. The goal of business is to reduce ISEb as much as possible. In the model shown, there is coupling between the government loop and the business loop with the result that propagation of signals in one loop affects the operation of the second loop. In the context of this work, conflict is defined to exist if the effect of the first loop upon the second loop is such that the performance index of the second is worsened, or increased in this case where the goal is to decrease the ISE. Similarly, cooperation is defined to exist if the coupling effect improves the performance index.

Simulation makes obvious that conflict and cooperation can exist because of signal injection or because of system modification without signal injection, or both. In Figure 7 no signal is injected by the business system, but because of the presence of the business feedback loop the government performance index ISEg is increased by a factor of $(34.81/6.68)$, or 5.2 to 1. By the definition above, conflict exists. On the other hand, in Figure 8 signal injection at the business reference input R_b along with the feedback in the business loop results in ISEg increase by a factor of $(132.3/6.68)$, or 19.8 to 1. Conflict from signal injection in this case results from the opposite signs in the reference input to the government loop and reference input to the business loop.

ADDITIONAL SIMULATION RESULTS

Additional simulation results are shown in Figures 9 and 10. Figure 9 shows the variation of the performance indices ISEg and ISEb with government reference R_g with business reference R_b held constant at unity. By the definitions above for cooperation and conflict,

cooperation increases as R_g varies from 0 to 1 and conflict increases as R_g varies from 0 to -1. There is a rapid increase in the error indices as the conflict increases and a rapid decrease in the error indices as the cooperation increases. Figure 10 shows the variation of the error indices as a function of the business reference R_b with the government reference held constant at unity. Again, there is a rapid increase in error indices as conflict increases and a rapid decrease in error indices as cooperation increases.

SUMMARY AND CONCLUSIONS

(1) Conflict may be defined by the actions of one participant, say business, tending to increase the performance index being minimized by the second participant, say government. Cooperation may be defined as existing when the actions of one of the participants tends to reduce the performance index being minimized by the second participant.

(2) Cooperation/conflict may result from either signal injection or from system modification, or both.

FUTURE WORK

(1) The effects of consumers should be added to the model. With three participants present, the possibility of joint cooperation/conflict arises. Include the effect of foreign investment.

(2) Practical data and reasonable scaling limits should be added. This probably requires participation of personnel with backgrounds in business and economics.

(3) Re-phrase the problem in terms of state variables and vector-matrix operations. Use modern control theory to re-design the controllers. Consider the possibility of decoupling output except from one input.

FINAL COMMENTS

(1) This is a work in progress.

(2) Results and conclusions, although believed to be original, are preliminary and should be considered as such.

REFERENCES

- [1] S.M. Shinnars, Modern Control Theory and Application, Reading, MA, Addison-Wesley, 1972.
- [2] R.L. Drake, "Do Checks and Balances Contribute to Cycles in the Economy?", MAESC 2003, Christian Brothers University, Memphis, TN, May 15, 2003.

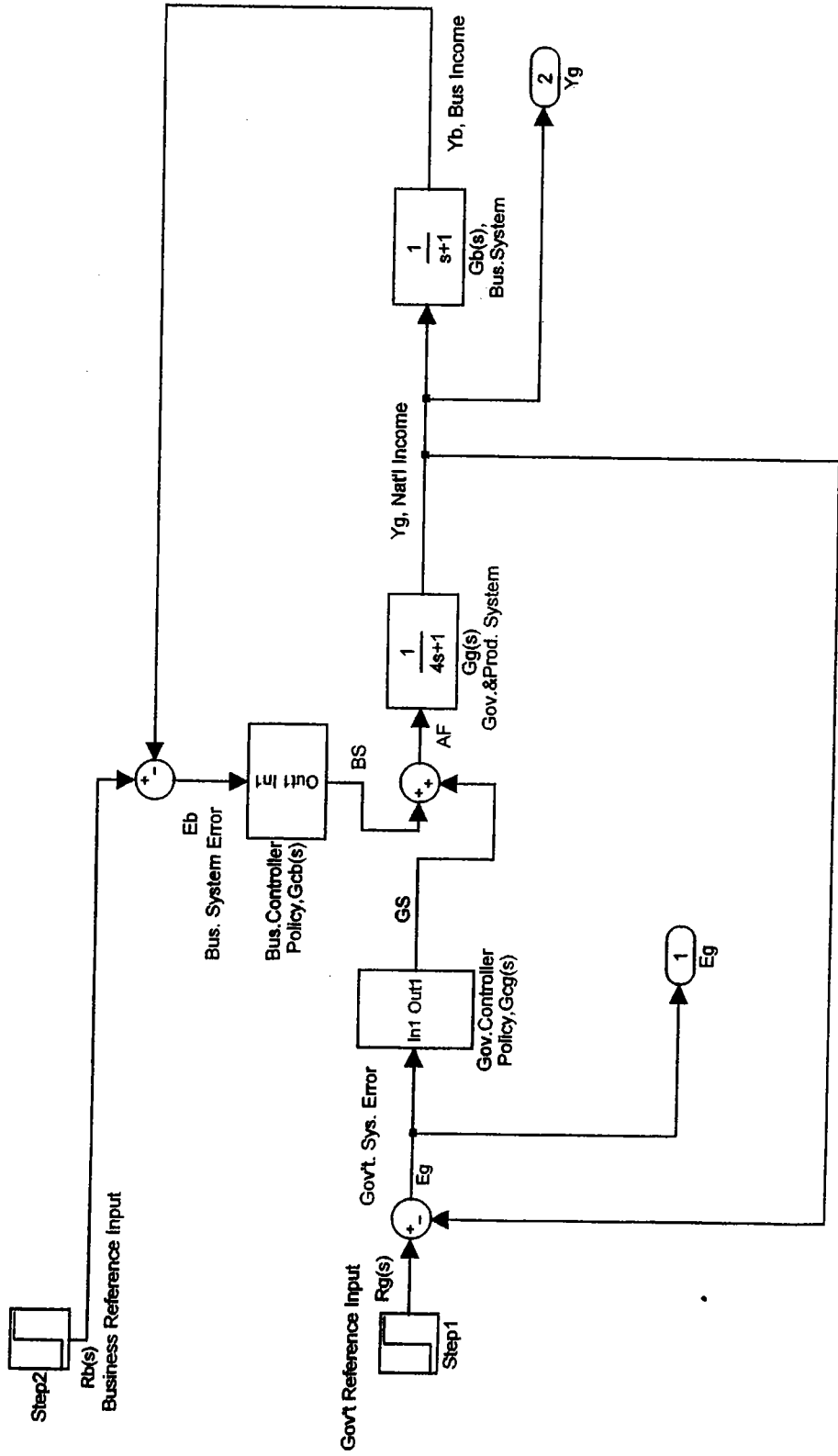

FIGURE 1 BLOCK DIAGRAM

AF=Available Funds
 GS(s)=Gov't Spending
 BS= Bus. Spending

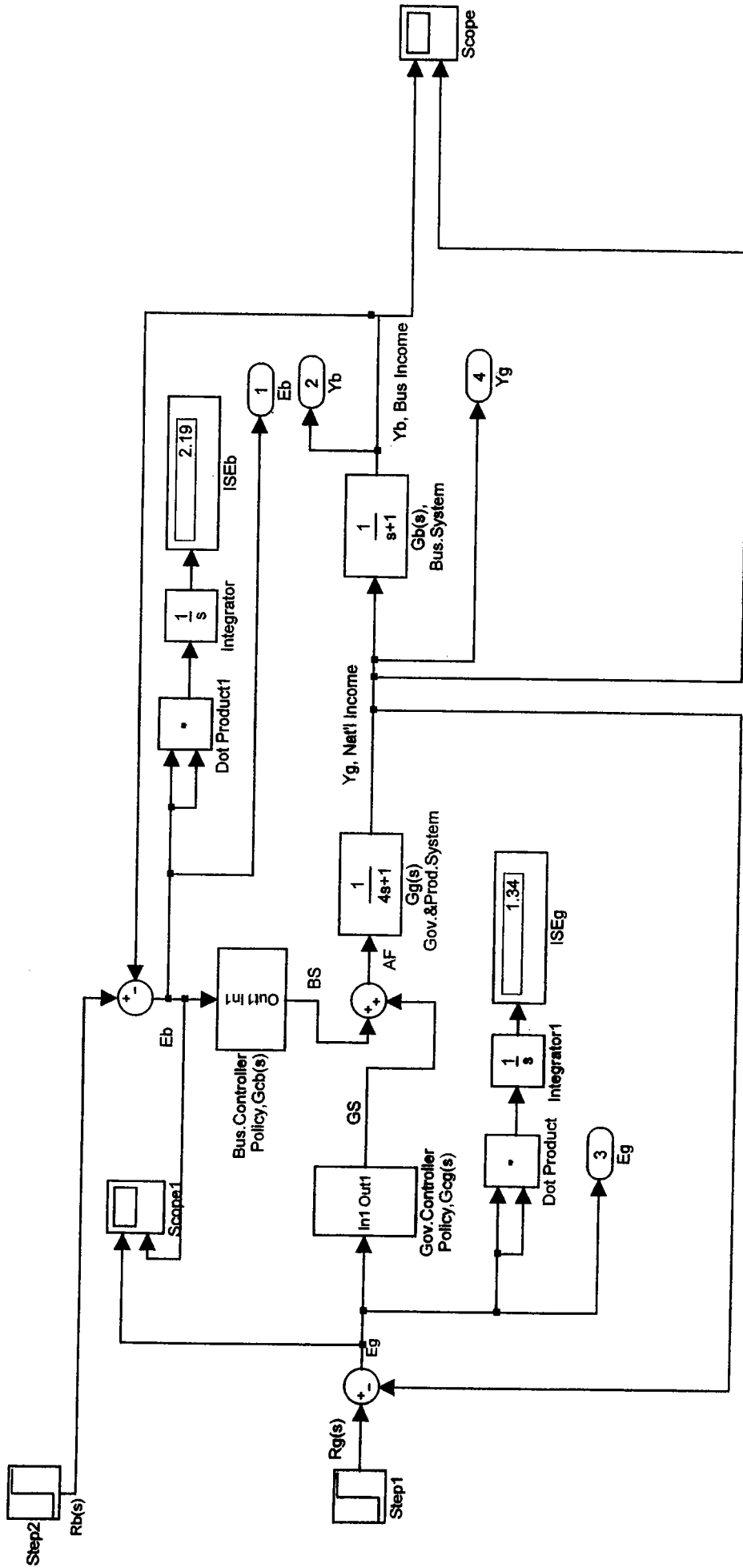

FIGURE 2 BLOCK DIAGRAM with VIRTUAL INSTRUMENTATION and COMPUTATION

AF=Available Funds
 GS(s)=Gov't Spending
 BS= Bus. Spending

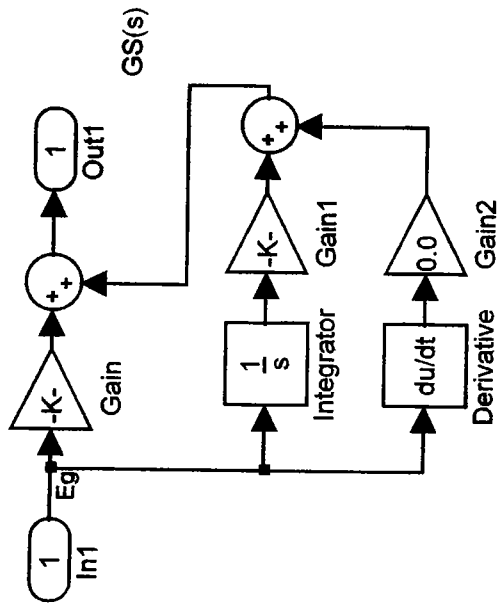

FIGURE 3 GOVERNMENT PI CONTROLLER

$K_p=0.1716$

$K_i=0.0858$

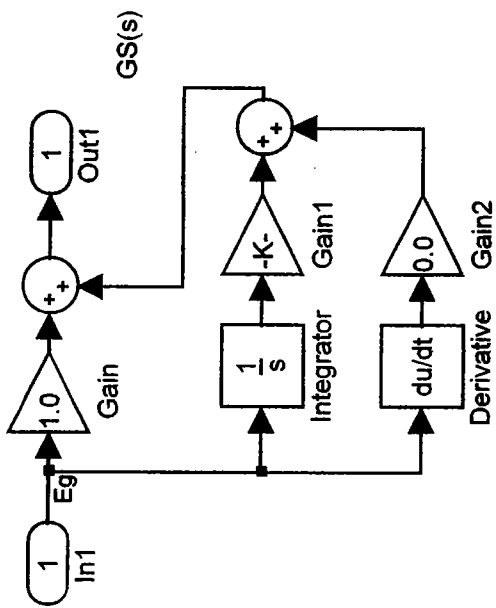

FIGURE 4 BUSINESS PI CONTROLLER

$Kp=1.0$
 $Ki=0.25$

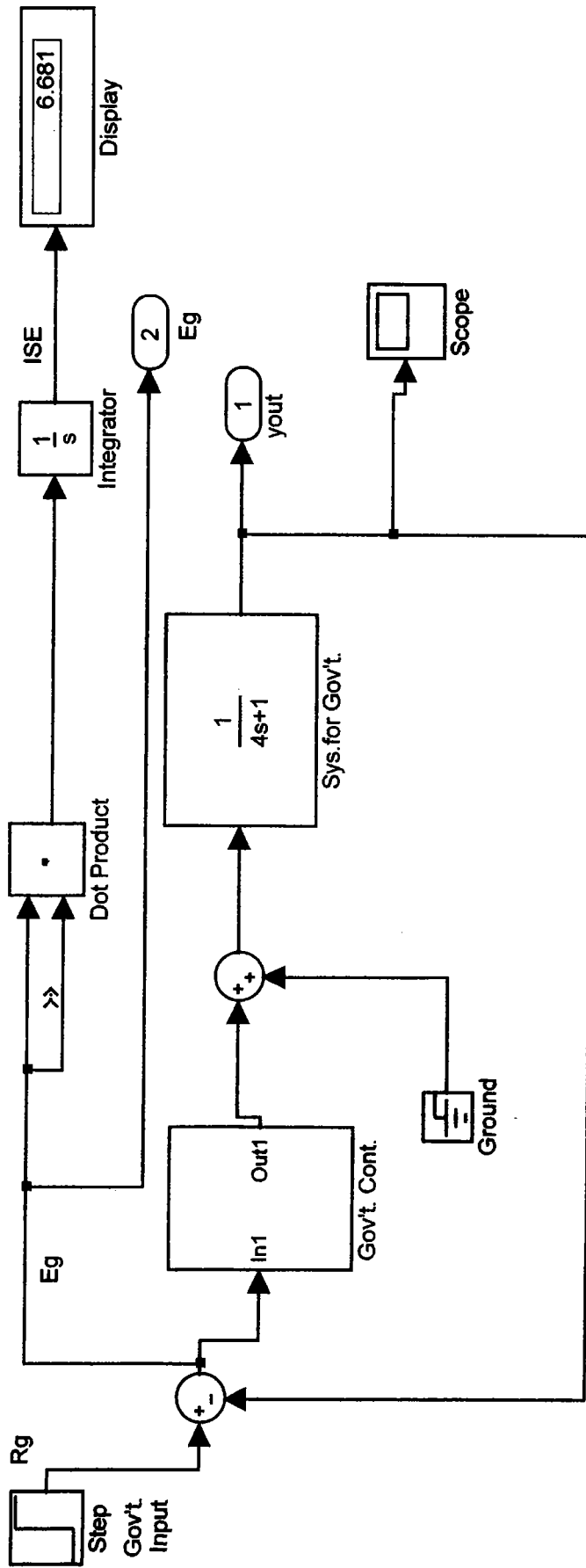

FIGURE 5 ISOLATED GOVERNMENT LOOP

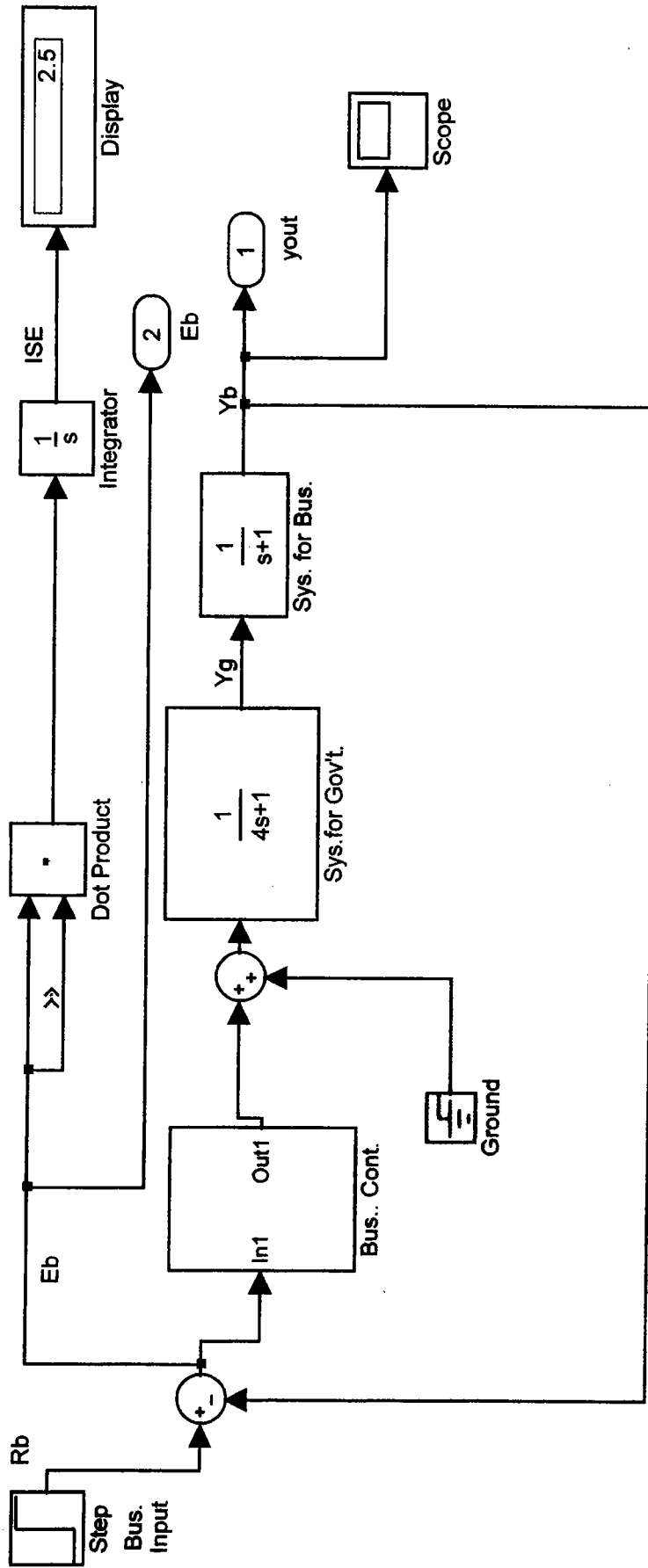

FIGURE 6 ISOLATED BUSINESS LOOP

Step2

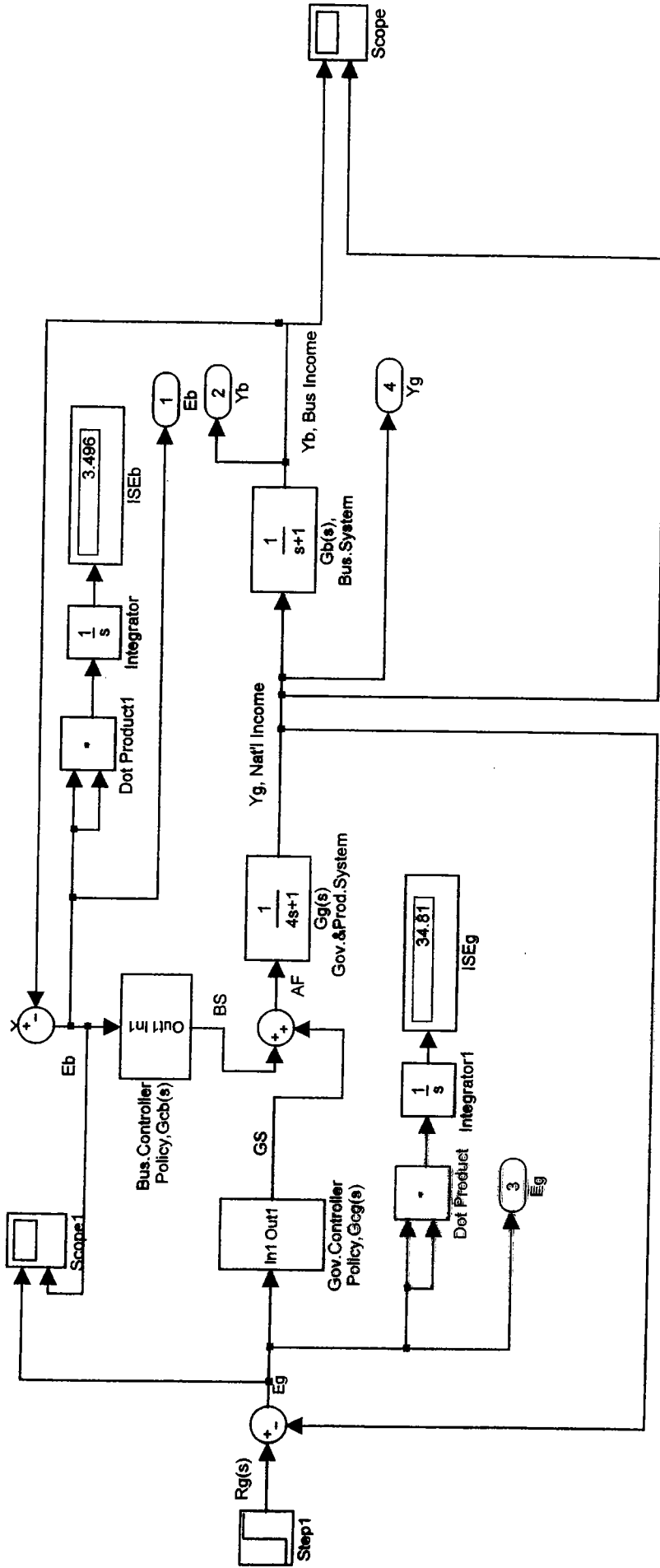

FIGURE 7 ZERO SIGNAL INJECTION FROM BUSINESS WITH SYSTEM MODIFICATION

AF=Available Funds

$GS(s)$ =Gov't Spending

BS = Bus. Spending

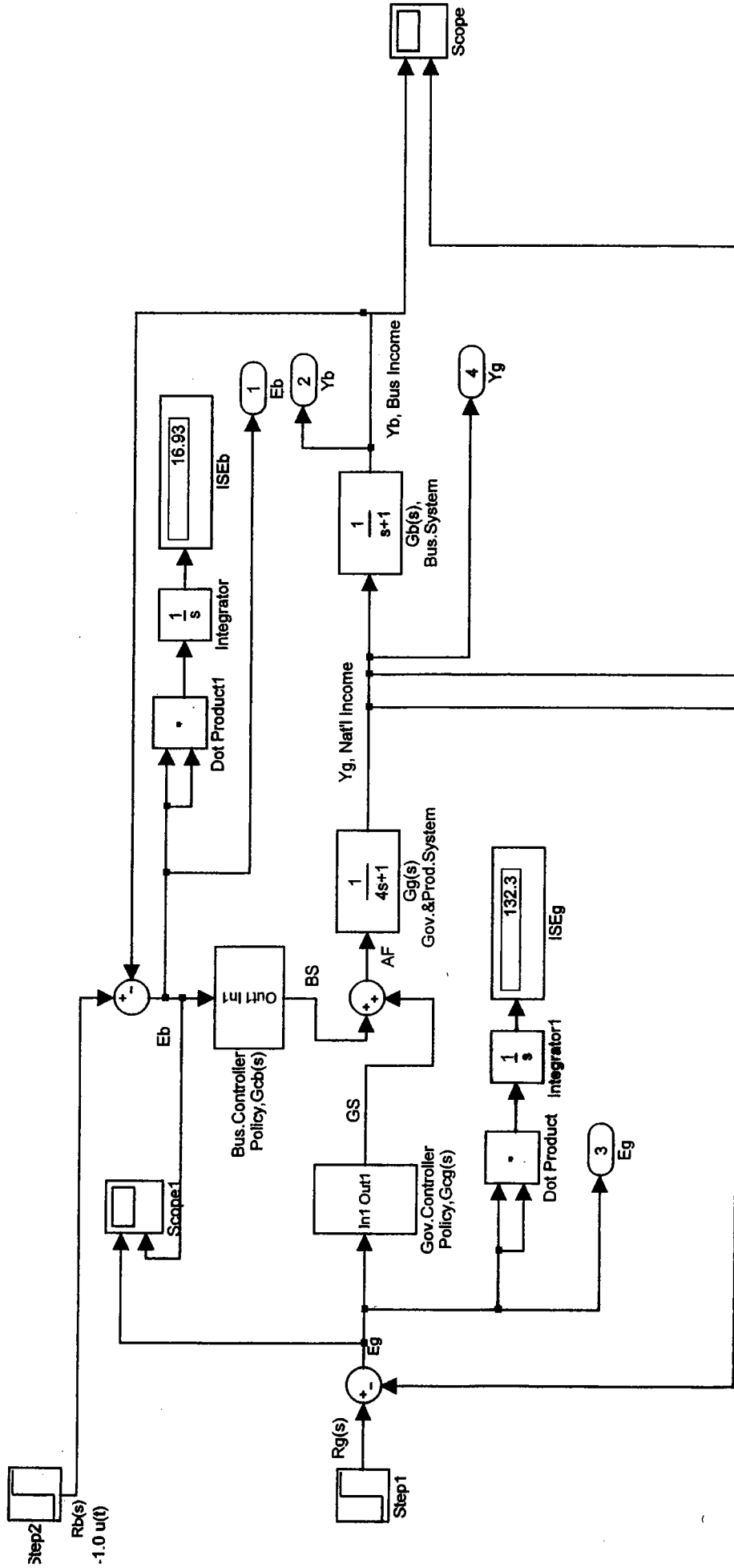
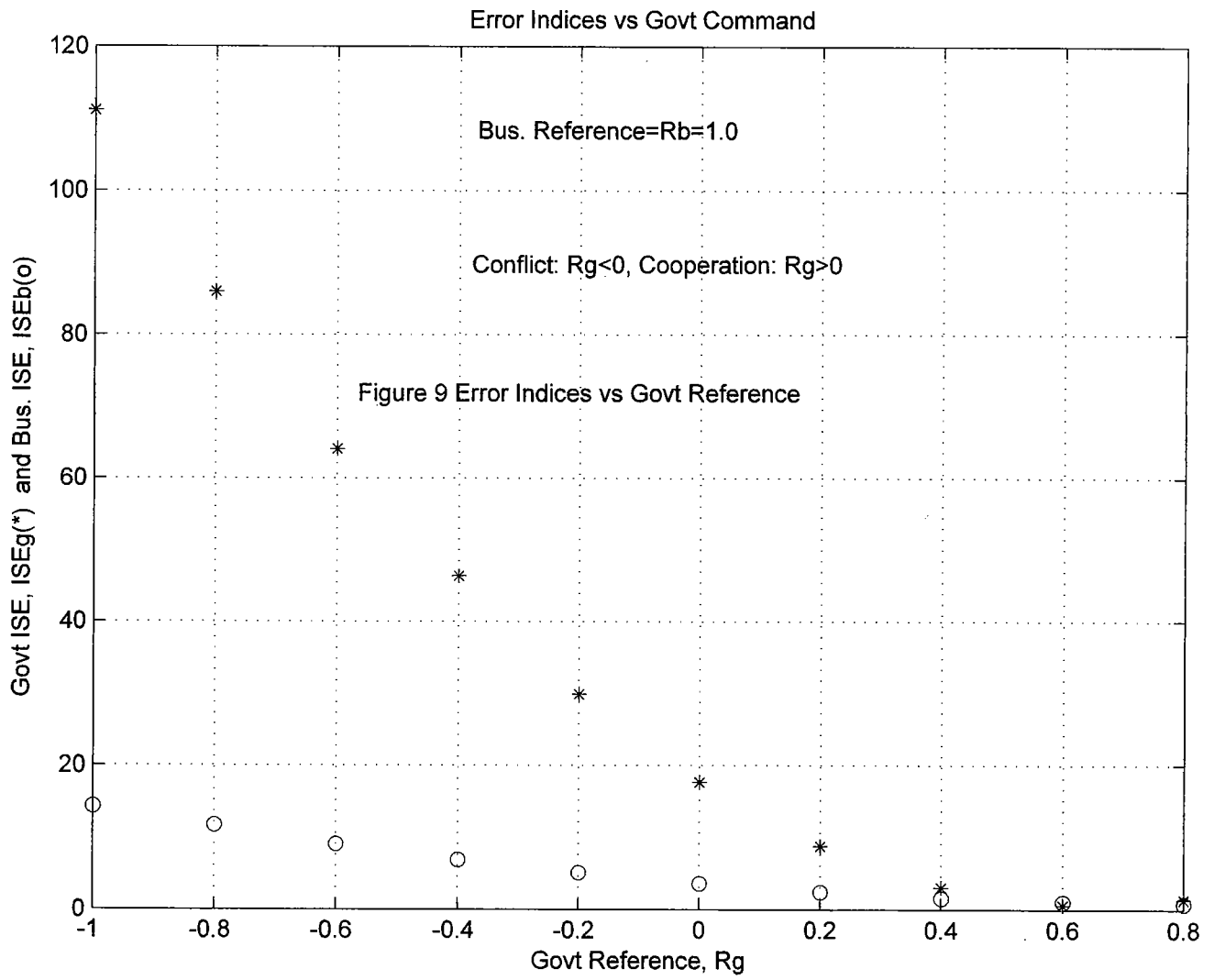

FIGURE 8 EXAMPLE OF CONFLICT THROUGH SIGNAL INJECTION

AF=Available Funds

GS(s)=Gov't Spending

BS= Bus. Spending



Error Indices vs Business Command

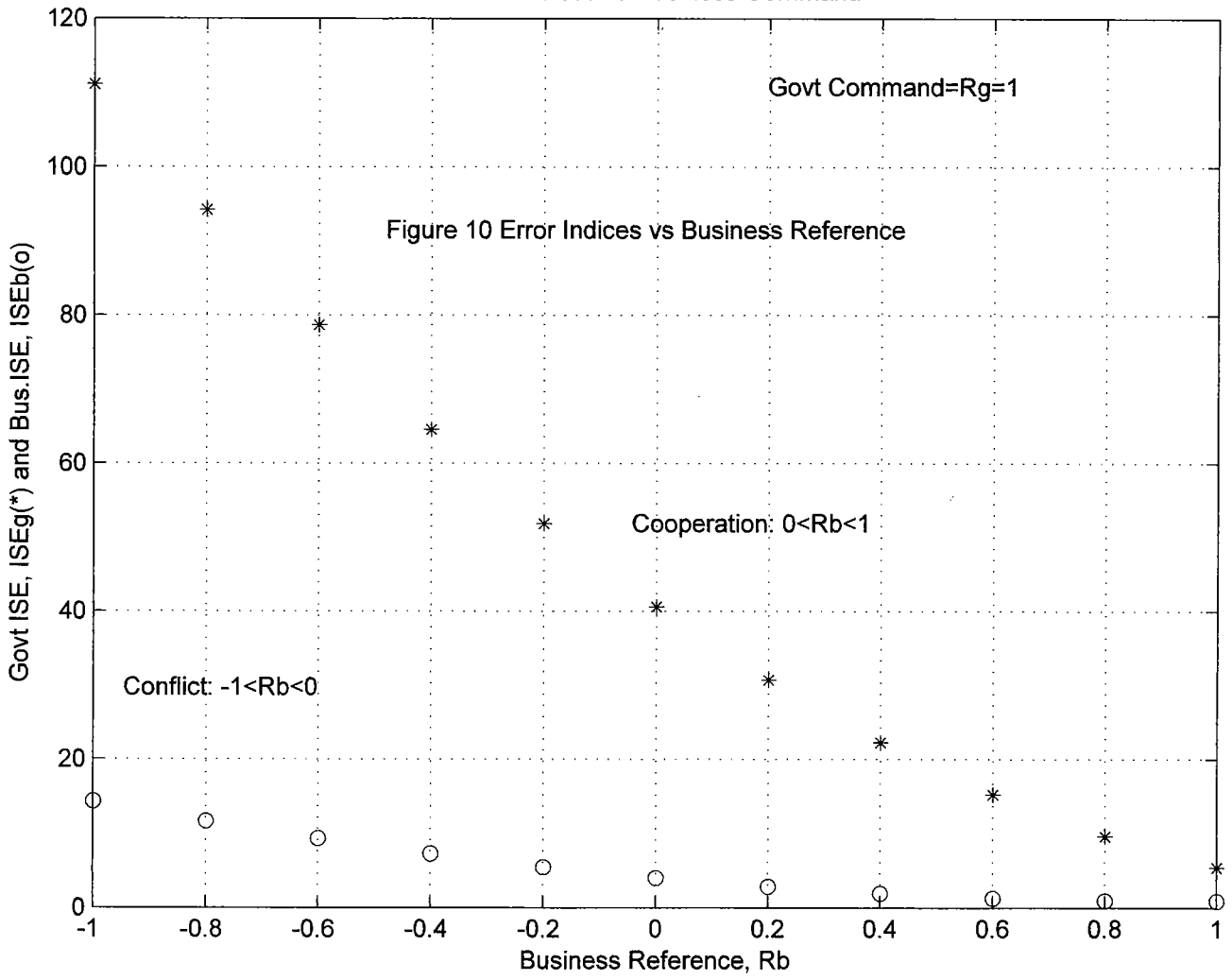

The National Economy as an Example of Control Under Conflict/Cooperation- A Simulation Approach

Robert L. Drake, Ph.D., P.E.
Department of Electrical and Computer Engineering
Christian Brothers University
Memphis, Tennessee
rdrake@cbu.edu

BACKGROUND

The work reported here is the result of teaching a course entitled ECE 488 Modeling and Simulation in Engineering Problems. This course is offered to students in both engineering and non-engineering. All students are required to simulate several dynamic systems during the semester at least one of which must be socio-political-economic (SPE) in nature. As instructor of the course, the writer chose the initial model of the national economy as an example of SPE systems to present to the class. This model was taken from reference [1] initially, and then as discussion progressed “refinements” were added. One of these refinements were reported in an earlier paper [2], where additional work suggested includes that of possible conflicts between the goals of government and the goals of business. The work reported here is the first attempt of the writer to approach that problem.

MODEL

The model hypothesized in this work is shown in the block diagram of Figure 1. Although inspired by the model suggested in reference [1], the model differs in several respects, among which are the inclusion of business investment as a separate input of the two-input system, identification of separate decision-making (controllers) for government and business, identification of different performance indices for government and business, and inclusion of two distinct outputs from the system. The inputs to the system are shown as business reference input (R_b) and the government reference input (R_g). The outputs from the system are shown as the national income level (Y_g) and the business income level (Y_b).

Figure 2 shows the identification of two performance indices chosen in this study. The performance index for government is based on the error, or difference, between the desired change in national income level and the measured change, E_g . In this case the integral squared value of this error is taken as the performance index. For business the error, or difference, is E_b as measured by the desired change in business income and the actual value. Again, the integral squared value of this error is used as the performance index.

Figure 3 shows the proportional plus integral (PI) controller chosen for the government controller. The controller constants were chosen to provide critical damping for the isolated government system. The government system is defined as isolated when the business input is set to zero (command for no change) and the business spending signal (BS) is set to zero. The simulation of the isolated government loop is shown in Figure 5 along with the indicated integral square error (ISEg) of 6.681 for the unit step response which can be checked with theory for this particular index of performance. Figure 4 shows the PI controller chosen for the isolated business loop and Figure 6 shows the simulation result for this case where the ISEb is 2.5 which also is checked by application of theory.

In Figure 1 the system representing government and production operations is shown with time constant of 4 time units and “dc” gain of 1. The system representing business operations is shown with time constant of 1 time unit and gain of 1.

DEFINITION OF CONFLICT AND COOPERATION

In Figure 2 the goal of government is to reduce as much as possible the performance index defined in this case as the integral square of the error signal E_g shown as ISEg. The goal of business is to reduce ISEb as much as possible. In the model shown, there is coupling between the government loop and the business loop with the result that propagation of signals in one loop affects the operation of the second loop. In the context of this work, conflict is defined to exist if the effect of the first loop upon the second loop is such that the performance index of the second is worsened, or increased in this case where the goal is to decrease the ISE. Similarly, cooperation is defined to exist if the coupling effect improves the performance index.

Simulation makes obvious that conflict and cooperation can exist because of signal injection or because of system modification without signal injection, or both. In Figure 7 no signal is injected by the business system, but because of the presence of the business feedback loop the government performance index ISEg is increased by a factor of $(34.81/6.68)$, or 5.2 to 1. By the definition above, conflict exists. On the other hand, in Figure 8 signal injection at the business reference input R_b along with the feedback in the business loop results in ISEg increase by a factor of $(132.3/6.68)$, or 19.8 to 1. Conflict from signal injection in this case results from the opposite signs in the reference input to the government loop and reference input to the business loop.

ADDITIONAL SIMULATION RESULTS

Additional simulation results are shown in Figures 9 and 10. Figure 9 shows the variation of the performance indices ISEg and ISEb with government reference R_g with business reference R_b held constant at unity. By the definitions above for cooperation and conflict,

cooperation increases as R_g varies from 0 to 1 and conflict increases as R_g varies from 0 to -1. There is a rapid increase in the error indices as the conflict increases and a rapid decrease in the error indices as the cooperation increases. Figure 10 shows the variation of the error indices as a function of the business reference R_b with the government reference held constant at unity. Again, there is a rapid increase in error indices as conflict increases and a rapid decrease in error indices as cooperation increases.

SUMMARY AND CONCLUSIONS

(1) Conflict may be defined by the actions of one participant, say business, tending to increase the performance index being minimized by the second participant, say government. Cooperation may be defined as existing when the actions of one of the participants tends to reduce the performance index being minimized by the second participant.

(2) Cooperation/conflict may result from either signal injection or from system modification, or both.

FUTURE WORK

(1) The effects of consumers should be added to the model. With three participants present, the possibility of joint cooperation/conflict arises. Include the effect of foreign investment.

(2) Practical data and reasonable scaling limits should be added. This probably requires participation of personnel with backgrounds in business and economics.

(3) Re-phrase the problem in terms of state variables and vector-matrix operations. Use modern control theory to re-design the controllers. Consider the possibility of decoupling output except from one input.

FINAL COMMENTS

(1) This is a work in progress.

(2) Results and conclusions, although believed to be original, are preliminary and should be considered as such.

REFERENCES

- [1] S.M. Shinnars, Modern Control Theory and Application, Reading, MA, Addison-Wesley, 1972.
- [2] R.L. Drake, "Do Checks and Balances Contribute to Cycles in the Economy?", MAESC 2003, Christian Brothers University, Memphis, TN, May 15, 2003.

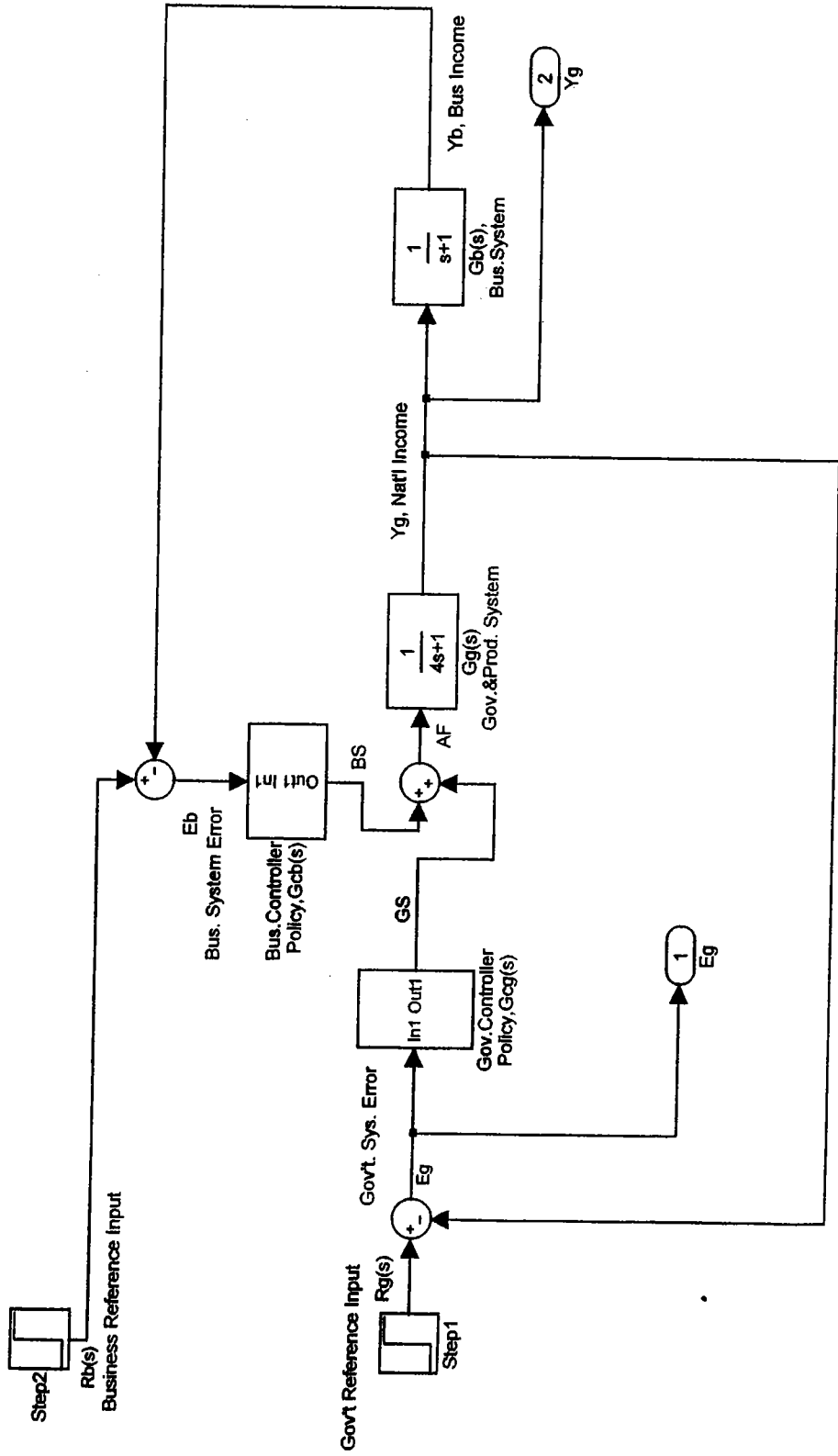

FIGURE 1 BLOCK DIAGRAM

AF=Available Funds
 GS(s)=Gov't Spending
 BS= Bus. Spending

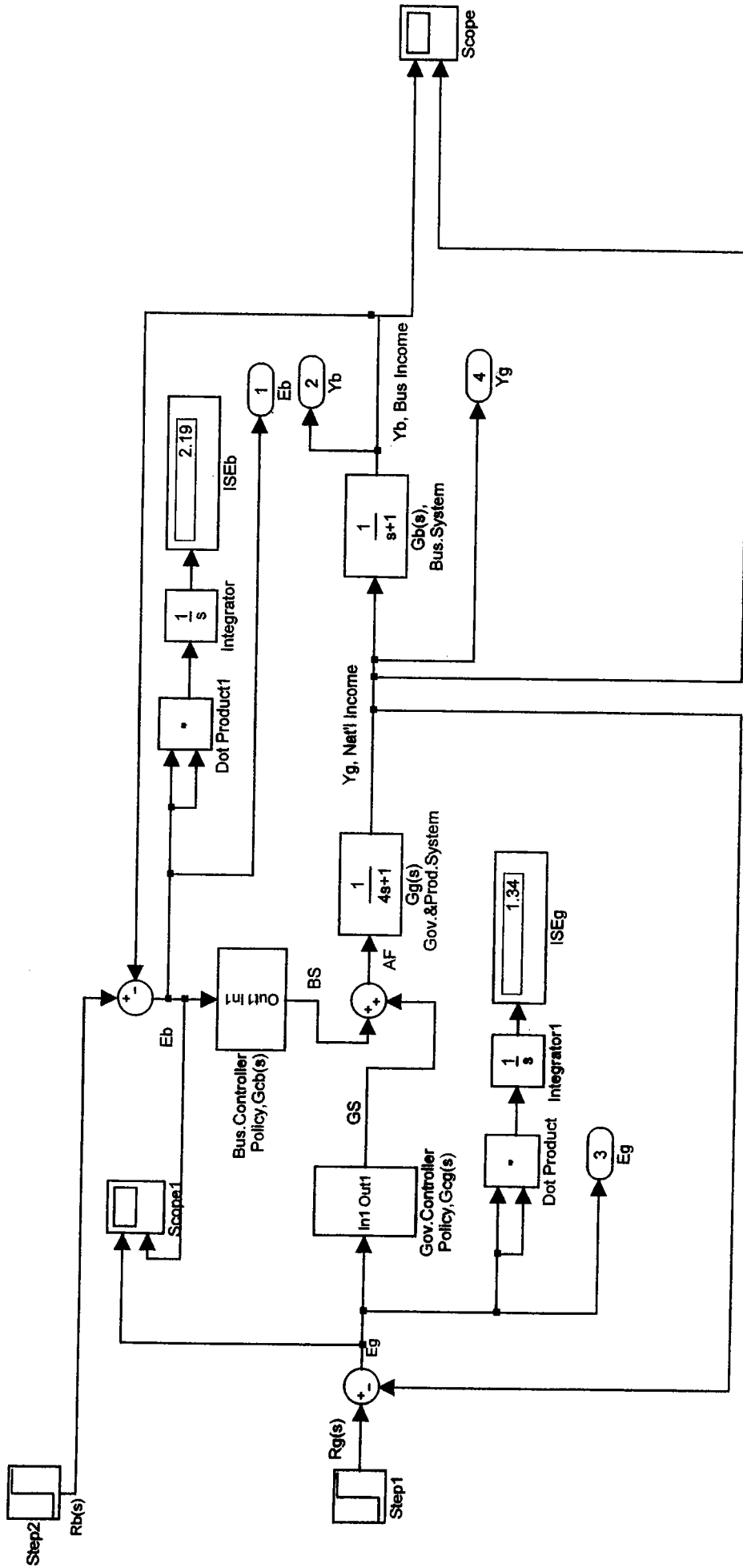

FIGURE 2 BLOCK DIAGRAM with VIRTUAL INSTRUMENTATION and COMPUTATION

AF=Available Funds
 GS(s)=Gov't Spending
 BS= Bus. Spending

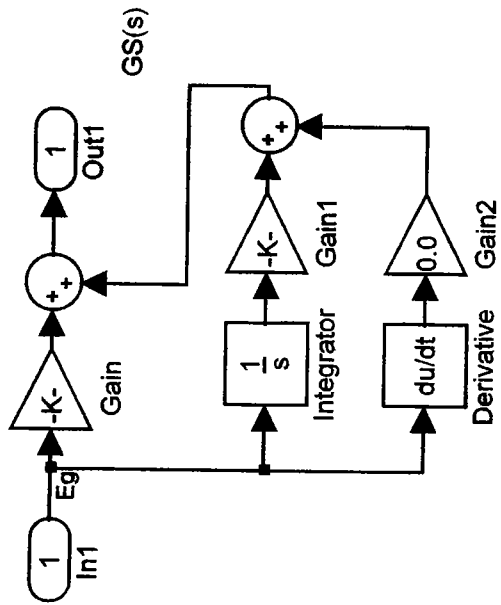

FIGURE 3 GOVERNMENT PI CONTROLLER

$Kp=0.1716$

$Ki=0.0858$

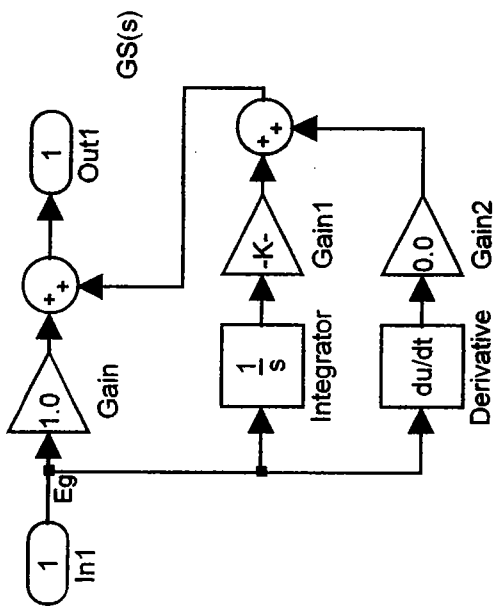

FIGURE 4 BUSINESS PI CONTROLLER

$Kp=1.0$
 $Ki=0.25$

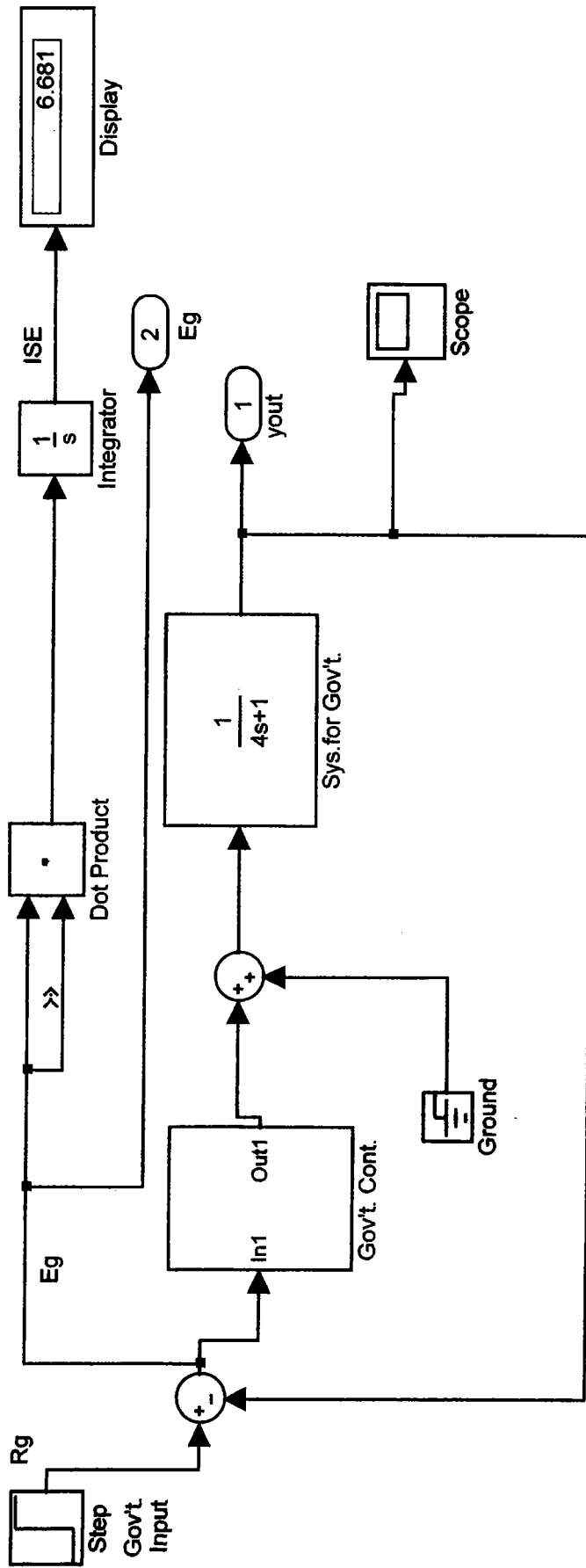

FIGURE 5 ISOLATED GOVERNMENT LOOP

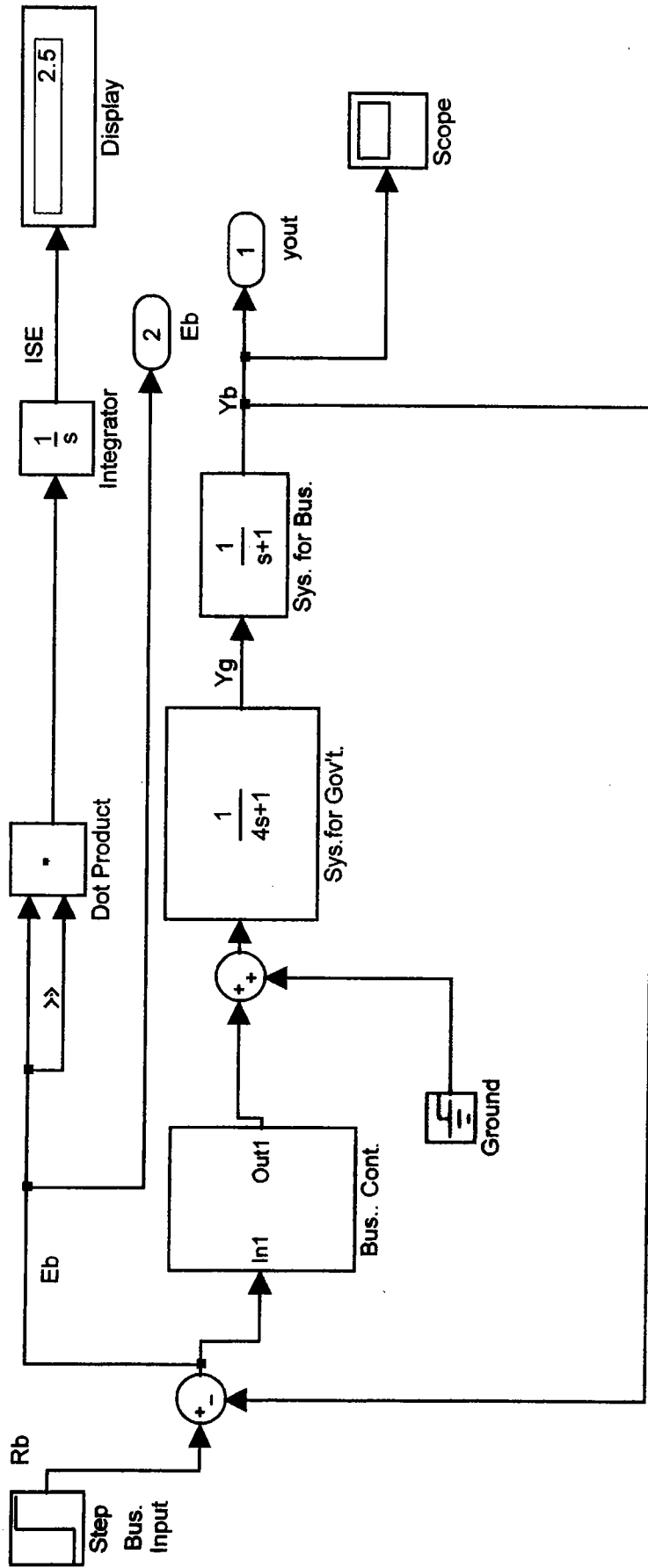

FIGURE 6 ISOLATED BUSINESS LOOP

Step2

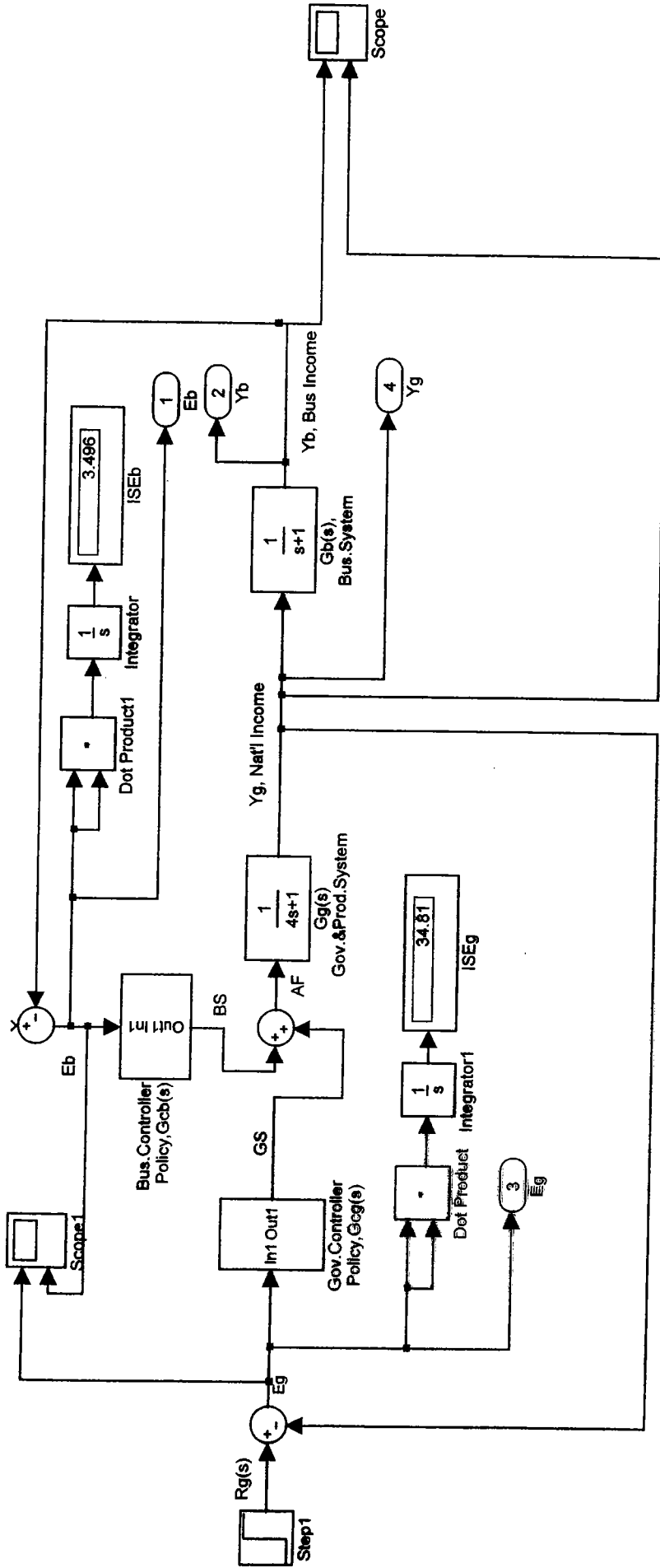
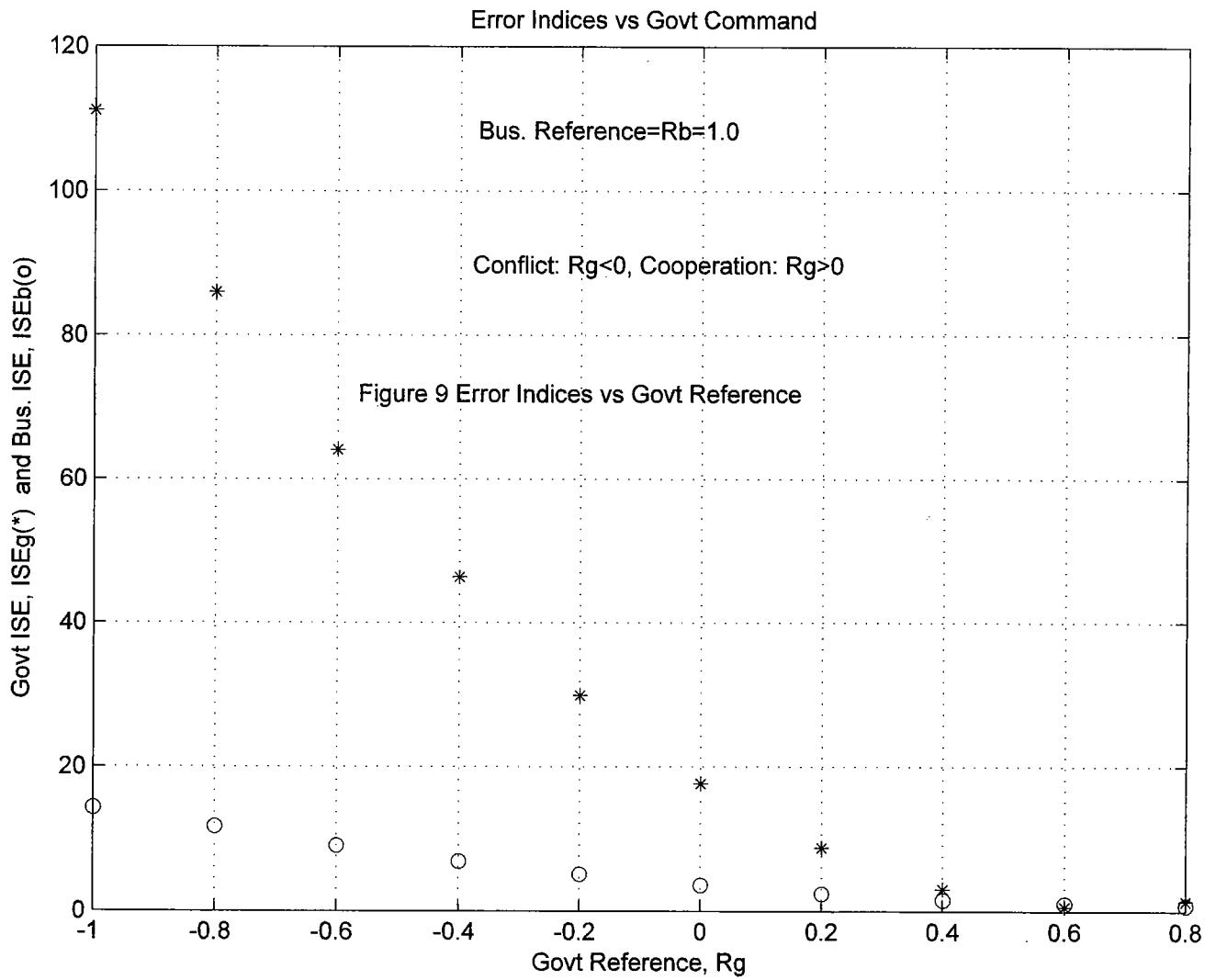

FIGURE 7 ZERO SIGNAL INJECTION FROM BUSINESS WITH SYSTEM MODIFICATION

AF=Available Funds

GS(s)=Gov't Spending

BS= Bus. Spending



Error Indices vs Business Command

